

# Outdoor Weatherproof Enclosure

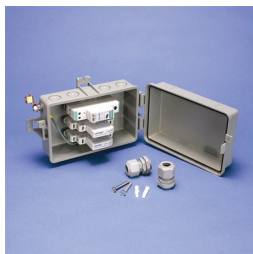

- Polymeric base and housing is impact resistant and UV-stabilized
- Integral mounting base for easy installation
- Quick-release latch with provisions for a lock
- Slots for Cable Ties strap allow mounting on both vertical and horizontal poles
- Grounding lug mounting option
- Two liquid tight strain reliefs included
- DIN rail included
- Stainless steel mounting hardware for long life and corrosion resistance
- Enclosure meets UL 94V-0 rain test requirements

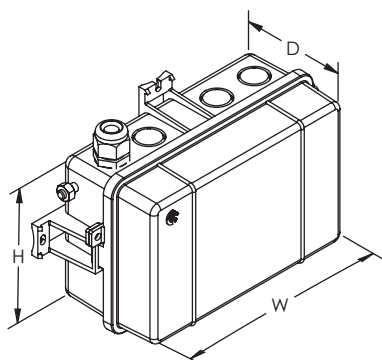

Part Number	MWE
Enclosure Material	UL <sup>*</sup> 94V-0 Thermoplastic
Strain Relief Cable Diameter	Gray, 4.6 - 11.2 mm
Knockout Sizes	(4) 22,5 mm (2) 28,4 mm
Depth (D)	89.4 mm
Height (H)	137.2 mm
Width (W)	221.4 mm
Unit Weight	0.54 kg

UL, UR, cUL, cUR, cULus and cURus are registered certification marks of UL LLC.

#### WARNING

Pentair products shall be installed and used only as indicated in Pentair's product instruction sheets and training materials. Instruction sheets are available at [erico.pentair.com](http://erico.pentair.com) and from your Pentair customer service representative. Improper installation, misuse, misapplication or other failure to completely follow Pentair's instructions and warnings may cause product malfunction, property damage, serious bodily injury and death and/or void your warranty.

© 2017 Pentair All rights reserved

Pentair, CADDY, CADWELD, CRITEC, ERICO, ERIFLEX, ERITECH and LENTON are owned by Pentair or its global affiliates.

All other trademarks are the property of their respective owners. Pentair reserves the right to change specifications without prior notice.