

HAE1\$0W SERIES

DC/DC Power Modules: 1\$0 watts



PCB Model

Terminal Block Model

Features

- NO MINIMUM LOAD REQUIRED
- 3000VAC REINFORCED INSULATION FOR 110VIN
2250VDC BASIC INSULATION FOR 24VIN AND 48VIN
- UL60950-1, EN60950-1, & IEC60950-1 SAFETY APPROVALS
- COMPLIANCE TO EN50155 AND EN45545-2 RAILWAY STANDARD
- CE MARKED
- COMPLIANT TO RoHS II & REACH

Applications

- RAILWAY SYSTEM
- WIRELESS NETWORK
- TELECOM/DATACOM
- INDUSTRY CONTROL SYSTEM
- DISTRIBUTED POWER ARCHITECTURES
- SEMICONDUCTOR EQUIPMENT

TECHNICAL SPECIFICATION All specifications are typical at nominal input, full load and 25°C otherwise noted

Model Number	Input Range VDC	Output Voltage VDC	Output Current @Full Load A	Input Current @ No Load mA	Efficiency %	Maximum Cap. Load uF
HAE100-24S3P3WP	9 ~ 36	3.3	25	20	91	75700
HAE100-24S05WP	9 ~ 36	5	20	25	93	40000
HAE100-24S12WP	8.5 ~ 36	12	8.4	25	90	7000
HAE100-24S15WP	8.5 ~ 36	15	6.7	25	91	4460
HAE100-24S24WP	8.5 ~ 36	24	4.2	25	90	1750
HAE100-24S28WP	8.5 ~ 36	28	3.6	25	90	1280
HAE100-24S48WP	8.5 ~ 36	48	2.1	35	90	430
HAE100-48S3P3WP	16.5 ~ 75	3.3	25	15	91	75700
HAE100-48S05WP	16.5 ~ 75	5	20	15	93	40000
HAE100-48S12WP	16.5 ~ 75	12	8.4	20	90	7000
HAE100-48S15WP	16.5 ~ 75	15	6.7	20	91	4460
HAE100-48S24WP	16.5 ~ 75	24	4.2	20	90	1750
HAE100-48S28WP	16.5 ~ 75	28	3.6	20	92	1280
HAE100-48S48WP	16.5 ~ 75	48	2.1	25	91	430
HAE100-110S3P3WP	43 ~ 160	3.3	25	10	87	75700
HAE100-110S05WP	43 ~ 160	5	20	10	90	40000
HAE100-110S12WP	43 ~ 160	12	8.4	10	90	7000
HAE100-110S15WP	43 ~ 160	15	6.7	10	90	4460
HAE100-110S24WP	43 ~ 160	24	4.2	10	90	1750
HAE100-110S28WP	43 ~ 160	28	3.6	10	90	1280
HAE100-110S48WP	43 ~ 160	48	2.1	10	91	430

- "P" indicates Positive Logic
- For terminal block type, add -T to part number (HAE1\$0-48S24W-PT)

PART NUMBER STRUCTURE

Series Name	Input Voltage (VDC)	Output Quantity	Output Voltage (VDC)	Input Range	Ctrl and Pin Option	Through Hole Type ⁽¹⁾	Assembly Option
HAE100 - 48 S 05 W - P TH HS	24:8.5~36 9~36 48:16.5~75 110:43~160	S:Single	3P3:3.3 05:5 12:12 15:15 24:24 28:28 48:48	4:1	□:Negative logic, 0.200" pin length L:Negative logic, 0.145" pin length P:Positive logic, 0.200" pin length S:Positive logic, 0.145"pin length	□: Thread TH: No thread	□: None Heat-sink type: HS: Height H=0.45" vertical fin, 7G-0021A-F HS1: Height H=0.24" horizontal fin, 7G-0022A-F HS2: Height H=0.24" vertical fin, 7G-0023A-F HS3: Height H=0.45" horizontal fin, 7G-0024A-F Terminal block type⁽²⁾: T: Wall mounted TF: Wall mounted with EMC filter ⁽³⁾ TF1: Wall mounted with EMC filter can be connected to PE ⚡ ⁽³⁾

(1) The module can't equip Heat-sink with TH option.

(2) Terminal block type only for 0.200" pin length.

(3) EMI filter meet EN55011, EN55022 Class A.

HAE1\$0W SERIES

DC/DC Power Modules: 1\$0 watts

INPUT SPECIFICATIONS							
Parameter	Conditions		Min.	Typ.	Max.	Unit	
Operating input voltage range		24Vin(nom)	3.3 & 5Vout	9	24	36	VDC
		48Vin(nom)	Others	8.5	24	36	
		110Vin(nom)		16.5	48	75	
Start up voltage		24Vin(nom)				9	VDC
		48Vin(nom)				18	
		110Vin(nom)				43	
Shutdown voltage		24Vin(nom)		7.3		8.1	VDC
		48Vin(nom)		15.5		16.3	
		110Vin(nom)		33.0		36.0	
Start up time	Constant resistive load	Power up		75			ms
		Remote ON/OFF		75			
Input surge voltage	1 second, max.	24Vin(nom)				50	VDC
		48Vin(nom)				100	
		110Vin(nom)				185	
Input filter (1)				Pi type			
Remote ON/OFF	Referred to -Vin pin	Negative logic	DC-DC ON			Short or 0 ~ 1.2VDC	mA
		(Standard)	DC-DC OFF			Open or 3 ~ 12 VDC	
		Positive logic	DC-DC ON			Open or 3 ~ 12 VDC	
		(Option)	DC-DC OFF			Short or 0 ~ 1.2VDC	
		Input current of Ctrl pin		-0.5		1	
Remote off input current				3			

OUTPUT SPECIFICATIONS						
Parameter	Conditions		Min.	Typ.	Max.	Unit
Voltage accuracy			-1.0		+1.0	%
Line regulation	Low Line to High Line at Full Load		-0.1		+0.1	%
Load regulation	No Load to Full Load		-0.1		+0.1	%
Voltage adjustability	Maximum output deviation is inclusive of remote sense		-20		+10	%
Remote sense	% of Vout(nom)				10	%
	If remote sense is not being used, Sense pins should be connected to corresponding polarity OUTPUT pins.					
Ripple and noise	Measured by 20MHz bandwidth					mVp-p
	With a 1µF/25V X7R MLCC & a 22µF/25V POS-CAP	3.3Vout, 5Vout		75		
	With a 1µF/25V X7R MLCC & a 22µF/25V POS-CAP	12Vout, 15Vout		100		
	With a 4.7µF/50V X7R MLCC	24Vout, 28Vout		200		
	With a 2.2µF/100V X7R MLCC	48Vout		300		
Temperature coefficient			-0.02		+0.02	%/°C
Transient response recovery time	25% load step change			200	250	µs
Over voltage protection	% of Vout(nom); Hiccup mode		115		130	%
Over load protection	% of Iout rated; Hiccup mode	24Vin(nom) and 48Vin(nom)	120		150	%
		110Vin(nom)		150		
Short circuit protection						Continuous, automatic recovery

GENERAL SPECIFICATIONS							
Parameter	Conditions		Min.	Typ.	Max.	Unit	
Isolation voltage	1 minute (Reinforced insulation)	110Vin(nom)	Input to Output	3000			VAC
			Input (Output) to Case	1500			
	1 minute (Basic insulation)	Others	Input to Output	2250			VDC
			Input (Output) to Case	1600			
Isolation resistance	500VDC		1			GΩ	
Isolation capacitance					2500	pF	
Switching frequency	24Vin(nom) and 48Vin(nom)		225	250	275	kHz	
	110Vin(nom)		270	300	330		
Safety approvals						UL60950-1 EN60950-1 IEC60950-1	
Case material	24Vin(nom) and 48Vin(nom)					Metal	
	110Vin(nom)					Aluminum base-plate with plastic case	
Base material	24Vin(nom) and 48Vin(nom)					FR4 PCB	
Potting material						Silicone (UL94 V-0)	
Weight	Module stand alone					105g (3.70oz)	
	HAE100-□□S□□W-T					235g (8.29oz)	
	HAE100-□□S□□W-TF					280g (9.88oz)	
	HAE100-□□S□□W-TF1					287g (10.12oz)	
MTBF	MIL-HDBK-217F, Full load					4.087×10 ⁵ hrs	

HAE1\$0W SERIES

DC/DC Power Modules: 1\$0 watts

ENVIRONMENTAL SPECIFICATIONS

Parameter	Conditions	Min.	Typ.	Max.	Unit
Operating case temperature	Base-plate	-40		+105	°C
Over temperature protection			+115		°C
Storage temperature range	Terminal block type Others	-40 -55		+105 +125	°C
Thermal impedance (2)	Vertical direction by natural convection (20LFM) Module without assembly option Heat-sink type with 0.24" Height Heat-sink type with 0.45" Height		6.7 5.4 4.7		°C/W
Thermal shock					MIL-STD-810F
Shock					EN61373, MIL-STD-810F
Vibration					EN61373, MIL-STD-810F
Relative humidity					5% to 95% RH

EMC SPECIFICATIONS

Parameter	Conditions	Level
EMI (3)	EN55011, EN55022	Class A Class B
ESD	EN61000-4-2 Air ±8kV and Contact ±6kV	Perf. Criteria A
Radiated immunity	EN61000-4-3 20V/m	Perf. Criteria A
Fast transient (4)	EN61000-4-4 ±2kV	Perf. Criteria A
Surge (4)	EN61000-4-5 EN55024 ±2kV and EN50155 ±2kV	Perf. Criteria A
Conducted immunity	EN61000-4-6 10Vr.m.s	Perf. Criteria A
Power frequency magnetic field	EN61000-4-8 100A/m continuous; 1000A/m 1 second	Perf. Criteria A

Notes:

- Input source impedance: The power module will operate as specifications without external components, assuming that the source voltage has a very low impedance and reasonable input voltage regulation. Highly inductive source impedances can affect the stability of the power module. Since real-world voltage source has finite impedance, performance can be improved by adding external filter capacitor. The HAE100-24S□□W and HAE100-48S□□W recommended Nippon Chemi-con KY series, 100µF/100V. The HAE100-110S□□W recommended Ruby-con BXF series, 68µF/200V.
- (1) Thermal test condition with vertical direction by natural convection (20LFM).
(2) The iron base-plate dimension is 19" X 3.5" X 0.063" (The height is EIA standard 2U).
(3) The heat-sink is optional and P/N: 7G-0021A-F, 7G-0022A-F, 7G-0023A-F, 7G-0024A-F. Please refer to heat-sink selection guide.
- The standard modules meet EN55011, EN55022 Class A or Class B with external components.
- An external input filter capacitor is required if the module has to meet EN61000-4-4, EN61000-4-5. The HAE100-24S□□W and HAE100-48S□□W recommended 2 pcs of aluminum electrolytic capacitor (Nippon Chemi-con KY series, 220µF/100V) to connect in parallel. The HAE100-110S□□W recommended 2 pcs of aluminum electrolytic capacitor (Nippon Chemi-con KXJ series, 150µF/200V) to connect in parallel.
- CASE GROUNDING : Connecting four screw bolts to shield plane will help to reduce the EMI.
- For further information, please contact with P-DUKE.

CAUTION: This power module is not internally fused. An input line fuse must always be used.

CHARACTERISTIC CURVE

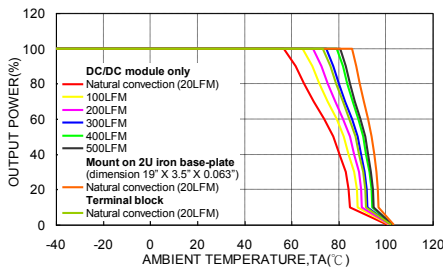

HAE100-48S05W Derating Curve (Note 2)

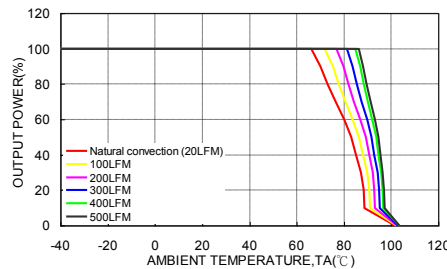

HAE100-48S05W Derating Curve (Note 2)
With 0.24" Height Heat-sink

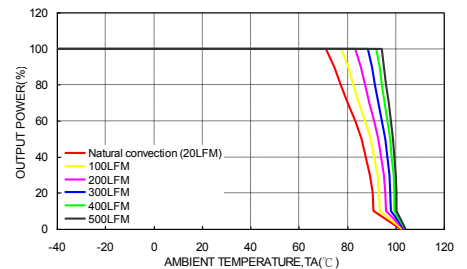

HAE100-48S05W Derating Curve (Note 2)
With 0.45" Height Heat-sink

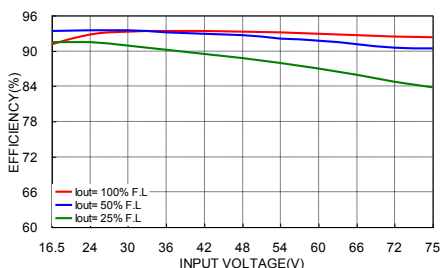

HAE100-48S05W Efficiency vs. Input Voltage

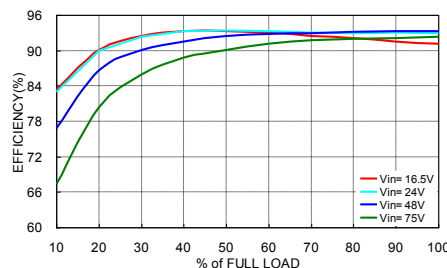

HAE100-48S05W Efficiency vs. Output Load

HAE1\$0W SERIES

DC/DC Power Modules: 1\$0 watts

MECHANICAL DRAWING - PCB Mounting

HAE100-24S□□W, HAE100-48S□□W

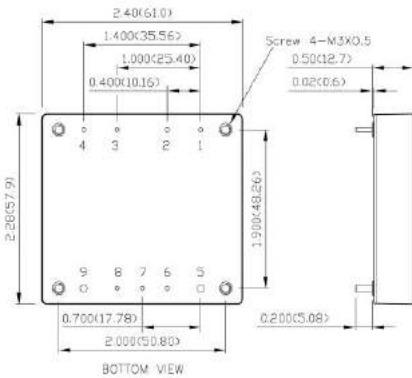

1. All dimensions in inch (mm)
2. Tolerance :x.xx±0.02 (x.x±0.5)
x.xxx±0.01 (x.xx±0.25)
3. Pin pitch tolerance ±0.01 (0.25)
4. Pin dimension tolerance ±0.004(0.1)
5. Mounting screws should always be used.
6. The screw locked torque:
MAX 5.0kgf-cm(0.49N-m)

HAE100-110S□□W

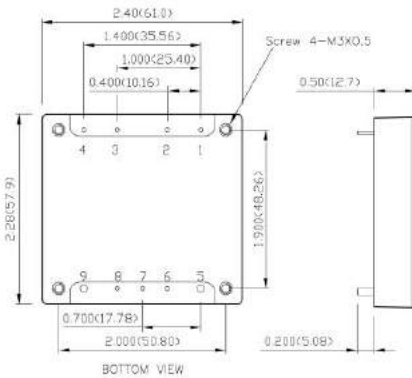

1. All dimensions in inch (mm)
2. Tolerance :x.xx±0.02 (x.x±0.5)
x.xxx±0.01 (x.xx±0.25)
3. Pin pitch tolerance ±0.01 (0.25)
4. Pin dimension tolerance ±0.004(0.1)
5. Mounting screws should always be used.
6. The screw locked torque:
MAX 3.5kgf-cm(0.34N-m)

PIN CONNECTION

PIN	DEFINE	DIAMETER
1	-Vin	0.04 Inch
2	Case	0.04 Inch
3	Ctrl	0.04 Inch
4	+Vin	0.04 Inch
5	-Vout	0.08 Inch
6	-Sense	0.04 Inch
7	Trim	0.04 Inch
8	+Sense	0.04 Inch
9	+Vout	0.08 Inch

EXTERNAL OUTPUT TRIMMING

Output can be externally trimmed by using the method shown below.

$$R_U = \left(\frac{V_{OUT}(100 + \Delta\%)}{1.225\Delta\%} - \frac{(100 + 2\Delta\%)}{\Delta\%} \right) k\Omega$$

$$R_D = \left(\frac{100}{\Delta\%} - 2 \right) k\Omega$$

HEAT-SINK TYPE OPTION

Vertical Fin Orientation, Suffix:-HS, -HS2

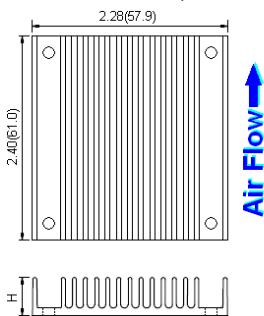

Horizontal Fin Orientation, Suffix:-HS1, -HS3

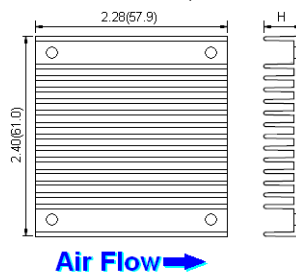

HS:	Height H=0.45" vertical fin, 7G-0021A-F
HS1:	Height H=0.24" horizontal fin, 7G-0022A-F
HS2:	Height H=0.24" vertical fin, 7G-0023A-F
HS3:	Height H=0.45" horizontal fin, 7G-0024A-F

1. All dimensions in inch (mm)
2. Tolerance :x.xx±0.02 (x.x±0.5)
x.xxx±0.01 (x.xx±0.25)

HAE1\$0W SERIES

DC/DC Power Modules: 1\$0 watts

TERMINAL BLOCK TYPE OPTIONS

HAE100-□□S□□W-T (Standard Terminal Block)

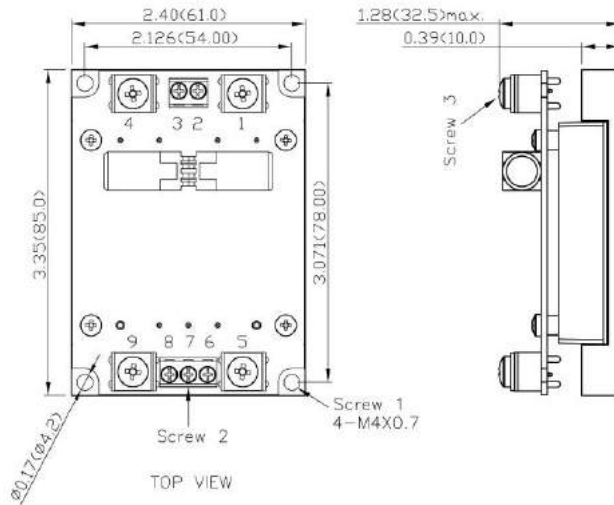

TERMINAL CONNECTION

NO.	DEFINE
1	-Vin
2	NC
3	Ctrl
4	+Vin
5	-Vout
6	-Sense
7	Trim
8	+Sense
9	+Vout

EXTERNAL OUTPUT TRIMMING

Output can be externally trimmed by using the method shown below.

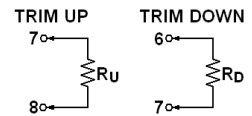

$$R_U = \left(\frac{V_{OUT}(100 + \Delta\%) - (100 + 2\Delta\%)}{1.225\Delta\%} \right) k\Omega$$

$$R_D = \left(\frac{100}{\Delta\%} - 2 \right) k\Omega$$

HAE100-□□S□□W-TF (Terminal Block with EMC Filter)

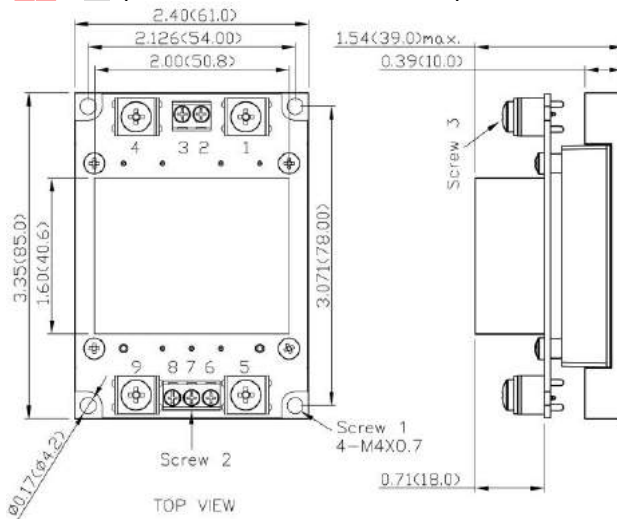

HAE100-□□S□□W-TF1 (Terminal Blok with EMC Filter)

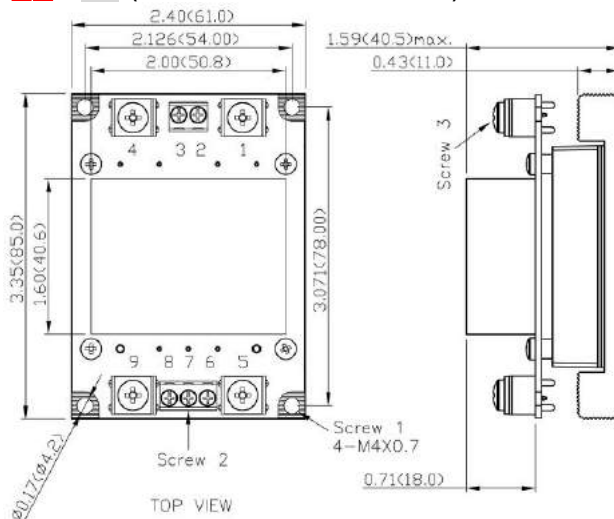

- All dimensions in inch (mm)
- Tolerance : x.xx±0.02 (x.x±0.5)
x.xxx±0.01 (x.xx±0.25)
- Screw 1 locked torque:
MAX 11.2kgf-cm/ 1.10N-m
- Screw 2 locked torque:
MAX 5.2kgf-cm/ 0.51N-m
- Screw 3 locked torque:
MAX 12.0kgf-cm/ 1.18N-m