

INSTRUCTION MANUAL

and
WARRANTY REGISTRATION CARD



**LS
SERIES**

500W to 1800W WALL MOUNT

TABLE OF CONTENTS

PAGE

INSTALLATION	2
BATTERIES	4
DIP SWITCH SETTINGS	5
AUTOMATIC TRANSFER SWITCH	7
INVERTER OPERATION	10
EFFICIENCY & OUTPUT WAVEFORM	12
AC WIRING & SAFETY	13
RADIO FREQUENCY INTERFERENCE	14
FAULT FINDING	16
WARRANTY CONDITIONS	17
INVERTER SPECIFICATIONS	18
WARRANTY REPAIR FORM	19
REGISTRATION WARRANTY CARD	21



INSTALLATION

- Ensure the Inverter has not been damaged in transit.
- The Inverter must *not* be installed outside
- The unit must be placed in a well-ventilated and protected area, not exposed to the open environment, and free from contaminants (i.e. exhaust gases, sea air, battery gases, dust).
- A space of 10cm is needed on each side of the Inverter for adequate transfer of internal heat.
- The Inverter can be mounted horizontally on a table or floor. The Inverter can also be mounted on a wall, taking note of the sticker being the correct orientation.

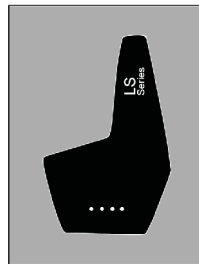
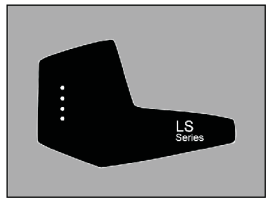

DC WIRING

- For best performance, the unit should be placed as close as possible, but not directly on top of the battery Supply.
- The Inverter DC input voltage is stated on the identification label of the Inverter. Check that it is the same voltage as the battery Supply.
- The Inverter is designed to operate on a battery Supply only.
- The Inverter is fitted with a circuit breaker in line with the Battery Positive Lead, which may reduce the need for a battery Fuse.
- Ensure the Inverter is switched OFF before connecting the DC supply. Turn the Circuit Breaker switch to the OFF position.
- Connect the Inverter DIRECTLY to the battery Terminals for optimal performance.
- Input leads marked RED = (positive), & BLACK = (negative).

OBSERVE POLARITY

NOTE: Cables connecting the Inverter to the battery are designed to achieve maximum efficiency and output power:
DC CABLES SHOULD NOT BE EXTENDED

APPLIANCES

Some appliances may have trouble running on inverters due to the current waveform they draw.

Certain appliance draw un-even load from a.c. supplies which from a mains supply might be OK but when operating from an inverter it may unbalance the internal toroidal transformer which can shut the inverter down. An example of an un-even current waveform is below

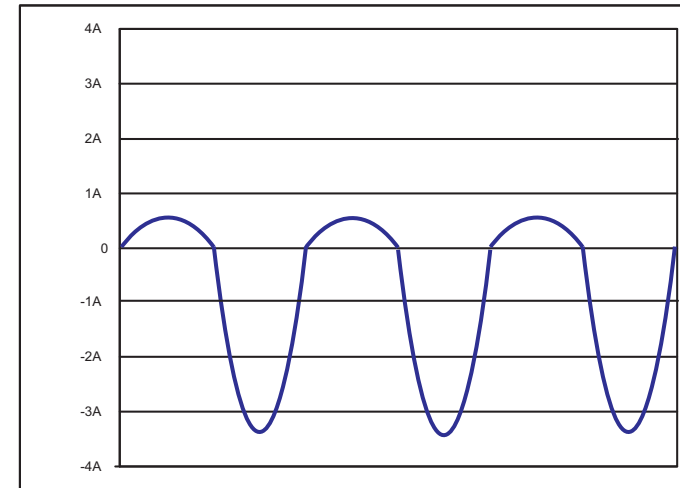

Some appliances that can cause this issue are

- Variable heat guns / hair dryers
- Washing machines / dish washers

This is not to say that the above appliances don't work, just a very small amount of models that draw very uneven current.

This imbalance can be evened out by applying more load or trying a different model/brand.

If you are having trouble with a certain appliance please call Latronics for further assistance

INVERTER SPECIFICATIONS

INVERTER MODEL	LS-512	LS-624	LS-648	LS-1012	LS-1224	LS-1248	LS-1512	LS-1824	LS-1848
Nominal DC Voltage	12V	24V	48V	12V	24V	48V	12V	24V	48V
Continuous Power	500W	600W	600W	1000W	1200W	1200W	1500W	1800W	1800W
1/2 Hour Rating	550W	750W	750W	1150W	1600W	1600W	1600W	2200W	2200W
Surge Rating (5 Secs)	1500W	2000W	2000W	3000W	3600W	3600W	4500W	5400W	5400W
Input Voltage Range	10.5-17V	21-34V	42-68V	10.5-17V	21-34V	42-68V	10.5-17V	21-34V	42-68V
Standby Current	27mA	22mA	19mA	37mA	28mA	22mA	42mA	30mA	24mA
Inverter ON-no load	0.42A	0.31A	0.15A	0.45A	0.25A	0.15A	0.67A	0.32A	0.18A
Peak Efficiency	90%	92%	93%	91%	92%	94%	91%	94%	94%
Weight	5.5Kg	5.5Kg	5.5Kg	11Kg	11Kg	11Kg	14Kg	14Kg	14Kg
Dimensions	260mm(L) x 160 mm(W) x 100 mm(H)								
Output Voltage	230Vac +/- 4%								
Output Frequency	50Hz +/- 0.1%								
Output Waveform	True Sinewave								
THD	< 4%								
Power Factor	All Conditions								
Autostart Sensitivity	0 - 20 W adjustable								
Operating Temperature	-10° C to +50° C								
DC to AC Isolation	3500 V								
Protection Circuitry	Overtemperature, Overload/Short Circuit, Battery Undervoltage/Overvoltage								
Battery Leads	1m with 10mm Lugs								
AC Output Wiring	Single Power Outlet								
Chassis	Powder Coated 2mm Aluminium								
Warranty	2 Years Parts and Labour								
Standards	AS2279, AS3000, AS3100, EN55014, & C-TICK								
Ratings	Specifications @ 25° C ambient nominal battery voltage & unity power factor								

Due to constant improvements, specifications are subject to change without prior notice.

WIRING DIAGRAMS for 12, 24 & 48 Volts DC

12-Volt System

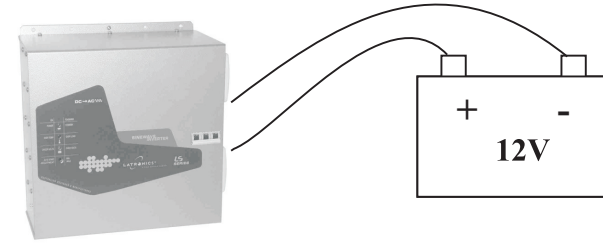

24-Volt System

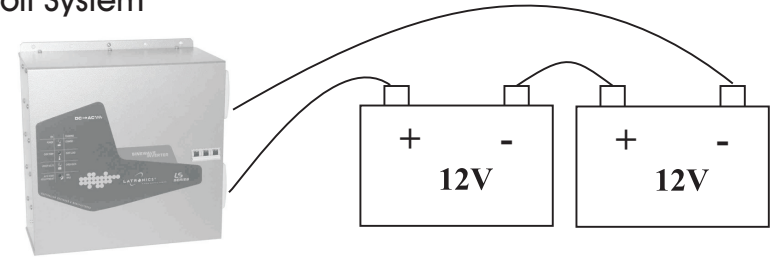

48-Volt System

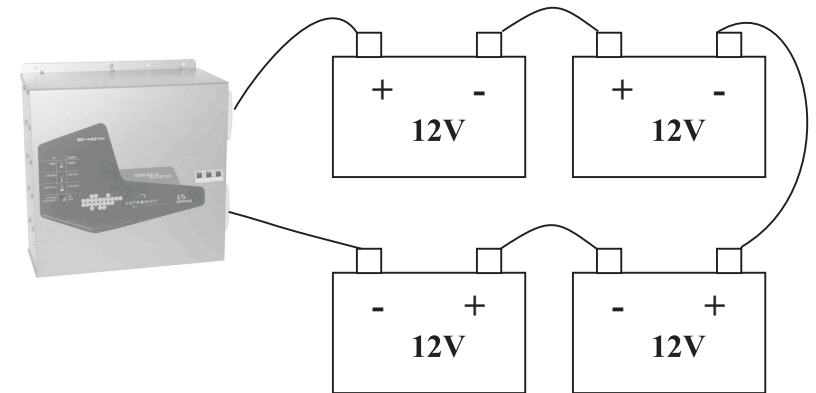

N.B. Ensure sufficient battery capacity to match load requirements!

BATTERIES

BATTERY SIZING

It is important to match your Battery size according to the power rating of the Inverter.

To ensure peak performance, it is important to choose the right Battery for your Inverter. The Battery size required will depend on the load and intended running time. Use this formula as a general guide:

Recommended Battery Size = Inverter rating in watts ÷ input voltage × 10

e.g. (1200W ÷ 12V) x 10 = 1000Ah

Minimum Battery Size = Inverter rating in watts ÷ input voltage × 3

e.g. (1200W ÷ 12V) x 3 = 300Ah.

Do not use an undersized Battery as this may result in an Inverter that does not start or that will rapidly discharge the Battery and may cause damage to the Battery.

MAINTENANCE

Battery Terminals require frequent care and maintenance. Very high current (up to several hundred amps), is drawn by the Inverter when starting electrical motors and other high power appliances. We recommend an inspection of the Batteries and the interconnecting cable connections once every 1-3 months or as recommended by the Battery manufacturer.

1. Regularly check all connections; make sure they are always tight.
Battery terminals are made of soft lead which will slowly compress over time eventually causing loose connections.
2. Check all connections are free of corrosion. Remove any corrosion and coat the terminals with Vaseline or grease to help prevent future corrosion.
3. Take specific gravity or SG readings of each cell using a hydrometer to check the level and performance of each Battery. Alternatively a Battery Voltage reading for each cell will suffice but may not be accurate for multiple Batteries connected in parallel. Report any serious imbalance to your system installer or Battery supplier for corrective action.

SAFETY

When working on Batteries protective clothing and eye wear should be worn. Extreme care should be taken not to short circuit any Battery terminals especially with tools. If in doubt have the work carried out by qualified personnel.

WARRANTY TERMS AND CONDITIONS FOR AUSTRALIA

Latronic Sunpower Pty Ltd ("Latronics") provides the original purchaser of a Latronics product ("You") with the following Limited Warranties as set out in this warranty certificate, in addition to your rights and remedies under consumer law. The Limited warranty periods of this inverter is 2 years. In all circumstances Latronics products are guaranteed from the date of purchase.

Part 1 - Warranty Descriptions

Latronics warrants to You that our products are guaranteed against defects in material or workmanship, when in normal use and service.

What you must do

1. For a Limited Warranty to apply the Registration Card must be validly completed by You and returned, prior to the expiration of 3 months from the date of purchase.
2. You must provide proof of purchase.
3. Latronics recommends You keep your receipt as proof of purchase, should any difficulties arise concerning the return of your Registration Card.

Exclusions:

For the avoidance of doubt, the Latronics product warranties provided herein do not cover damage, malfunctions or service failures caused by, amongst other things:

- Unauthorized opening of the products, repair, alteration or substitution of nonstandard parts;
- Incorrect design and/or installation of 'balance of system';
- Acts of god, accident or similar cause;
- Failure to follow Latronics installation, operation or maintenance instructions;
- Abuse, misuse or negligent acts;
- Power failure surges, lightning, fire, flood, pest damage, accidental breakage, actions of third parties and other events or accidents outside Latronics' reasonable control and not arising from normal operating conditions;
- Suitably qualified personnel not carrying out all AC and DC permanent wiring in accordance with relevant wiring rules.

Products supplied by Latronics, or Latronics agents are supplied under the express condition that no responsibility is implied or accepted by Latronics for any damage to any appliance, equipment or property used in combination with the correct operation of a Latronics product.

All conditions and warranties expressed or implied by statute, common law, equity, trade, custom, usage, or otherwise however are hereby expressly excluded to the maximum extent permitted by law. Where so permitted, the liability of Latronics for a breach of condition or warranty that cannot be excluded is limited (at Latronics option) to the replacement or repair of the goods or of acquiring equivalent goods or the cost of replacing or repairing the goods or of acquiring equivalent goods.

Latronics does not undertake any commitment to guarantee continuity of supply in the case of obsolescence. In addition, Latronics reserves the rights to change its standard product range or specification of any model subsequently without notice and no liability as a result of these occurrences will be accepted.

Our goods come with guarantees that cannot be excluded under the Australian Consumer Law. You are entitled to a replacement or refund for a major failure and compensation for any other reasonably foreseeable loss or damage. You are also entitled to have the goods repaired or replaced if the goods fail to be of acceptable quality and the failure does not amount to a major failure.

Part 2 - Returning a Latronics product for service under warranty;

If service is required contact your local supplier/installer or place of purchase for advice.

To Claim Under Warranty:

1. You should contact the Customer Care Centre on 1300 550 204. Product Model number and Serial number need to be readily available to enable prompt processing.
2. If, after investigation, the Customer Care Centre determines the product is or may be defective in material or workmanship and within the warranty period, they will issue instructions on how to proceed with return and shipping to Latronics.
3. When packaging a Latronics product for return appropriate measures must be taken by You to ensure the products are safely packed for transit. Products damaged in transit due to inadequate packaging will be void of warranty.
4. If the product manual has a Warranty Return Form included, this form should be completed and accompany products being returned.
5. If, as a result of further investigation by or on behalf of Latronics, such a defect is confirmed, then Latronics must, at its sole election, either repair or replace your Latronics product. Latronics will also, at their discretion, determine the most appropriate means to return any Warranty repairs (or replacements) to You in a timely manner.

Part 3 - General Information

Replacement of any part or labour involved in repairs will not have the effect of extending the original period of the Limited Warranty of the goods. Any faulty part replaced under Limited Warranty becomes the property of the Company for purpose of examination and claim under proprietary warranty.

Under these product warranties, Latronics is not responsible for and you hereby agree to bear any costs associated with removal, transportation or reinstallation of Latronics products or any peripheral components in the balance of any system used in conjunction with Latronics products.

Products returned to Latronics without prior authorisation will be returned to the sender at their expense.

All Warranty repairs are completed ex-factory to ensure

- Fast service turn around time
- Specialised, factory trained technicians
- All required components are available (except in the case of obsolescence)
- Thorough testing to all Latronics specifications
- Dedicated test equipment
- Upgrades/updates to latest Latronics standards/specifications (where applicable).

FAULT FINDING

Should the Inverter appear to be malfunctioning we suggest the following to eliminate any external problems:

1. Turn the Inverter "OFF" via the Circuit Breaker switch on the front panel.
2. Disconnect all AC wiring from the Inverter.
3. Disconnect DC Battery leads from Battery. Clean all terminals by removing all grease/corrosion on both DC leads and Battery terminals.
4. Ensure you have sufficient Battery capacity at the nominal voltage (specified on the compliance label of your Inverter).

Please note: Use minimum 100AH Battery or the size of a substantial Car Battery.

5. Make connection directly to Battery terminals and ensure all connections are tight.
6. Remove other wiring from battery to ensure that the Inverter is the ONLY device connected to battery bank
7. Ensure Battery voltage is within the correct limits as outlined in the section *INVERTER SPECIFICATIONS* of this manual. If you do not have a DC voltmeter or multimeter check the front panel for Overvolts and Undervolts LEDs.
8. Turn the Inverter ON via the Circuit Breaker switch on the front panel. Observe the lights on the front left of your Inverter. Refer to *INVERTER OPERATION* sections for explanation of Indicator lights.
9. Plug in various appliances and monitor the Inverters operation.

HELPFUL HINTS

- * Remember that the Inverter automatically starts when a load is applied.
- * Make sure leads and terminals are not corroded or faulty in any way.
- * Make sure the Inverter goes into STANDBY with no load switched on.
- * Make sure the Circuit Breaker is reset properly. If unsure switch OFF and ON again.
- * In extreme weather it is suggested to shutdown and unplug the unit.

DIP SWITCH SETTINGS

Dip switch settings apply to all models from 1000W-1800W inclusive.

In order to access these options you have to open the Inverter. Before altering the settings switch the Inverter OFF, adjust the setting and switch the Inverter back ON again. We recommend these adjustments be carried out by qualified personnel or your system installer.

SW1 Hz 50/60 Hz
ON = 50Hz (factory setting) OFF = 60Hz

If you need to operate American or Japanese equipment this option will allow your Inverter to operate at 60Hz.

SW2 & SW3 SP Special
SW4 AR Automatic Reset
OFF=Disabled ON=Enabled (factory setting)

This feature is designed to restart the Inverter and maintain power in the event of an external fault. Should the Inverter shut down due to under voltage, over temperature or any fault condition it will attempt to reset every 8 minutes until the fault condition clears and normal operation resumes.

For overload shutdown the Inverter will only attempt 5 restarts. If the Inverter can not resume normal operation within 5 restarts, it will remain OFF until reset manually. This prevents continuous re-application of power to faulty appliances or wiring.

For under voltage shutdown the Inverter will restart when the battery voltage reaches the reconnect value as shown in the table below.

SW5 & SW6 UV Under Voltage Settings
SW5 OFF & SW6 OFF= (factory setting)

Setting		12V Value		24V Value		48V Value	
SW5	SW6	Disconnect	Reconnect	Disconnect	Reconnect	Disconnect	Reconnect
ON	ON	10.0	12.0	20.0	24.0	40.0	48.0
OFF	OFF	10.5	12.5	21.0	25.0	42.0	50.0
ON	OFF	11.0	13.0	22.0	26.0	44.0	52.0
OFF	ON	11.5	13.5	23.0	27.0	46.0	54.0

DIP SWITCH LOCATION

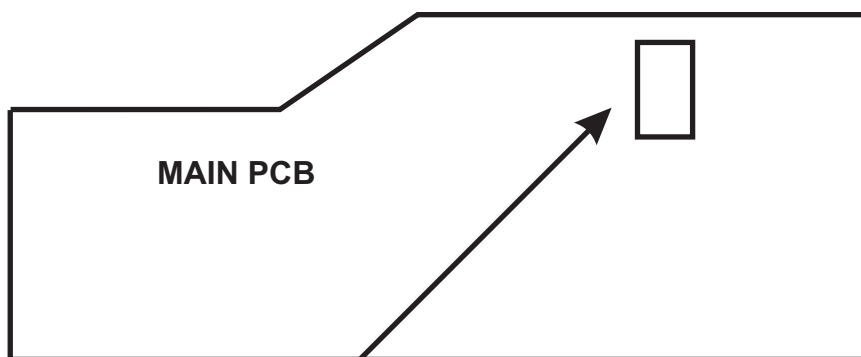

MAIN PCB

1
2
3
4
5
6

DIP Switch located on Main PCB

OFF ON

WARNING:

Due to dangerous voltages existing inside the unit, make sure the circuit breaker switch is turned off before opening the unit. Should you have any doubt about performing these modifications, we strongly recommend the use of a qualified trades person.

DECLARATION OF CONFORMITY

Manufacturer:
Latronic Sunpower Pty Ltd
79 William Street
Moffat Beach Industrial Park
Caloundra Queensland 4551
Australia

Declare that the LS series of inverters conform to the requirements of following standards

EN61000-6-1
EN61000-6-3
EN55014
AS1044
EN60335-1
AS/NZS 3100
IEC 62109-1
IEC 62109-2



And therefore conform to the regulations of the EC directives
Directive 2004/108/CE (EMC directive), Directive 2006/95/CE (low Voltage
Directive)
Date that CE marking was first affixed 2007

Also conforms to the RCM marking regulations for Australian emission standards

All products are manufactured with full traceability in accordance with the
Quality System Requirements of AS/NZS ISO 9002

Signed

William Pettit
Electronic Engineer
1st March 2016

RADIO FREQUENCY INTERFERENCE

Radio Frequency Interference (RFI) is a phenomenon that exists in modern society and is a problem in many areas of electronics. For Inverter users, RFI normally presents itself in the form of static and/or interference when listening to an AM radio and in unusual cases may interfere with TV reception.

Over the years Latronics has continued to invest significant time and effort in the reduction of RFI related emissions from the entire product range, so that they comply with the appropriate International and/or Australian Standards.

Even with this compliance, there are situations where RFI may still be a cause for concern, and can differ greatly from installation to installation. Accordingly, the following is a list of recommendations made to assist in the overall reduction of RFI.

1. *Separate DC and AC wiring.* Avoid running DC and AC cables in the same conduits and/or cable trenches. It is strongly recommended that DC and AC wiring be separated by the greatest distance possible. In extreme cases, the use of shielded conduit may be necessary.
2. *Minimize length of DC cabling.* DC cables can act as an aerial, therefore all such cables should be kept as short as is practicable. For best performance minimize DC cable length to Inverter and Batteries and if possible avoid the use of auxiliary DC loads.
3. *240Vac Earth.* For household installations, it is recommended that a "good" Earth Stake is located as nearby the Inverter as is possible.
4. *AM and HF Radios.* These types of radio equipment inherently suffer from all forms of RFI, especially when the received signal level is weak. In such cases reception can sometimes be improved by relocation of the radio itself, alternatively the use of an appropriate external antenna and co-axial cable may be necessary. External antennas should be located in a manner that ensures maximum signal strength whilst affording the greatest possible distance away from the Inverter and Batteries.
5. *Televisions.* TV signals are transmitted as FM waveforms. This type of signal fundamentally reduces the effects of RFI, therefore the use of a good antenna and feeder cable is normally sufficient to ensure quality reception. Locating the television as far as possible from the Inverter may also improve picture clarity.
6. *Mobile Installations.* Due to the limitations of this type of installation, the best results for the minimization of RFI are usually obtained by maximizing the distance between the Inverter and the Radio/Television.

AUTOMATIC AC TRANSFER SWITCH (Option)

Eliminates the need to manually switch your power source between Inverter and Generator. The Transfer Switch automatically senses Generator AC power and switches the output between Inverter and Generator accordingly.

Features

- * Available exclusively to the LS series from 1000W to 1800W models.
- * No Break changeover time of 0.02 second (< one cycle).
- * Double pole contactor switching both active and neutral.

Please Note: The AUTOMATIC AC TRANSFER SWITCH is now available as a separate device in a 2 (ACTS40) or 3 (ACTS3) way version.

If you do not have a Latronics transfer switch but another manual or automatic switch, please ensure you wait 5 seconds between switching from one source to another. Fast switching may damage the inverter.

SYSTEM BLOCK DIAGRAM

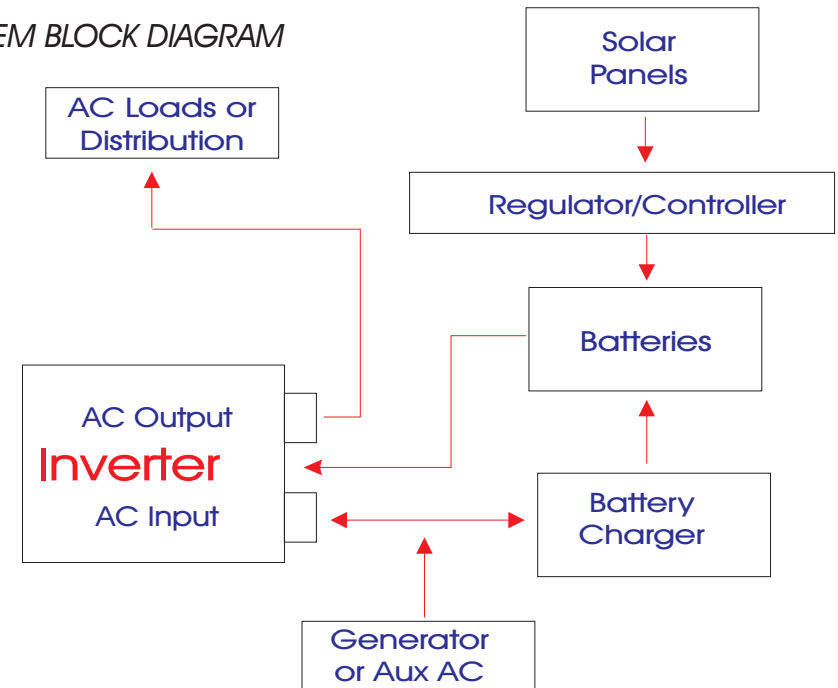

- * Installation of system components and associated interconnecting wiring, should be performed by qualified and licensed personnel only.

Notes:

.....

.....

.....

.....

.....

.....

.....

.....

.....

.....

.....

.....

.....

.....

.....

.....

.....

.....

.....

.....

.....

.....

.....

SAFETY

Inverter Isolation and Safety

- * All standard Latronics Inverters have an isolation rating of 3500V between AC and DC via the toroidal transformer, which ensures extremely safe and risk free operation.
- * When switching the output of the inverter ensure that the switch is a double pole switching device switching both active and neutral.
- * All the switching electronics and control circuitry are on the DC input.
- * The single pole Circuit Breaker assembly ensures that when the Inverter is switched OFF, it is isolated from the Battery supply.

Please refer to relevant Australian Standards for safety procedures.

AC WIRING

- * Make sure the Inverter is switched OFF before working on the mains wiring. Turn the circuit breaker switch into OFF position.
- * In standard Latronics inverters the active and neutral of the 230V AC output are electrically isolated from the battery negative, battery positive, and earth connections.
- * The Inverter AC output is connected directly to the Transformer output winding.
- * Standard Latronics Inverters have the AC output (active and neutral) floating with respect to the DC and Earth. The Earth connection is connected to the case only. This configuration provides the highest safety and most flexibility for installation wiring.
- * Latronics Inverters are suitable for MEN connection.
- * The Earth is connected internally to the Inverter case.

Ensure that power will never be fed into the Inverter AC output Junction Box from the Mains or Generator. *This would result in the destruction of the unit and will not be covered by warranty.*

WARNING:

The Inverter output is just as lethal as normal mains electricity It is important that all AC wiring complies with the requirements of the relevant wiring standards, (AS 3000). Any work carried out on AC/Mains wiring is to be performed by Qualified and Licensed personnel only.

INVERTER EFFICIENCY & OUTPUT WAVEFORM

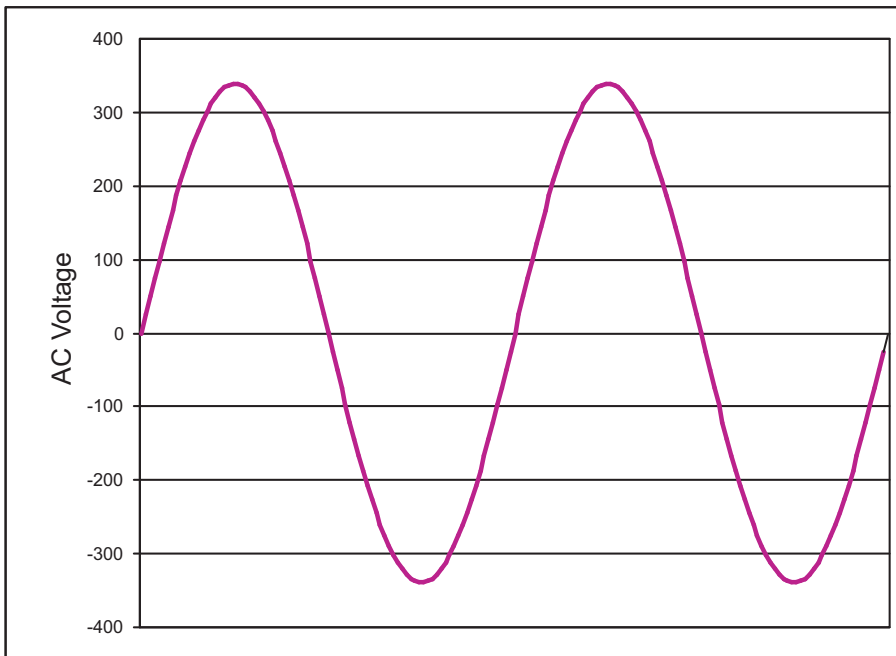
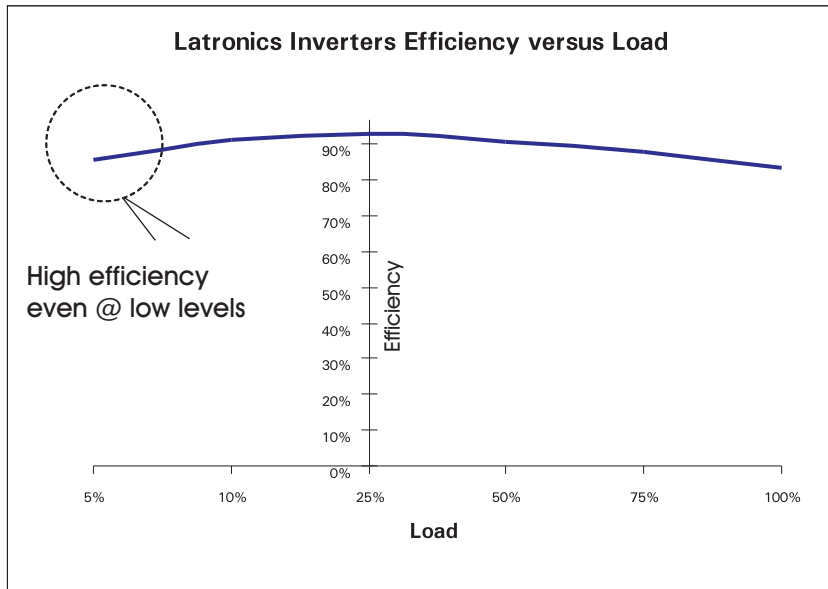

Notes:

.....

.....

.....

.....

.....

.....

.....

.....

.....

.....

.....

.....

.....

.....

.....

.....

.....

.....

.....

.....

.....

.....

INVERTER OPERATION

When the Inverter is switched on all 3 LEDs light up for 1 second while the microprocessor performs a start up and system check procedure.

Over temp./Over load (Red LED)
If the internal temperature exceeds safe operating limits of the components for more than five seconds, the Inverter will shut down in Over temp with this LED on continuously. Allow 5 minutes for the Inverter to cool and reset the unit. If the APPLIED load demands more current than the Inverter can safely supply for more than 5 seconds, the Inverter will shutdown in Over load and this LED will flash.

Undervolts/Overvolts (Red LED)
In order to protect the battery the Inverter will shutdown after 5 seconds if the battery voltage falls below its limit, (Undervolts), or exceeds the maximum, (Overvolts), as specified in the Electrical Specifications table. For Undervolts the LED will remain on continuous, while for an Overvolts situation the LED will continue to flash.

Power Outlet
Single unswitched socket

AutoStart Sensitivity Adjustment
The screwdriver adjustment slot permits the operator to adjust sensitivity between 0- 20W. Due to lengthy AC cables the Inverter may sense fake loads. To combat this, turn the control clockwise. Alternatively turning the control in the opposite direction increases sensitivity. Turning the control fully anti-clockwise will disable the Auto Start feature and the Inverter will remain constantly ON.

Standby/240 volts (Green LED)
This LED flashes when in Standby mode (i.e. no loads connected). When a load is applied the LED will illuminate continuously to indicate that 240V AC is being supplied.

Fan
If the temperature inside the inverter reaches preset levels, the dual speed fan will switch on initially in low speed and then into high speed if the temperature continues to increase. Obstruction of the air intake and output will reduce the power rating of the Inverter.

Circuit Breaker ON/OFF Switch
The circuit breaker is designed for ease of operation and safety. By pushing the switch "UP", the battery supply is connected to the Inverter. The circuit breaker will turn OFF automatically or the Overload LED will illuminate if too large a load is left on the Inverter continuously. Reset the switch after allowing approximately 5 minutes to cool. If the Inverter shuts down due to Undervolts or Overvolts it can be reset by turning the circuit breaker OFF, waiting 10 seconds (or until LED goes out), then turning it on again.

Hardwire- 3 Terminal Output Junction Box
For distribution of AC output power.
1000W - 1800W Models only.

Battery leads
DC leads RED = battery positive, Black = battery negative.

Hardwire-3 Terminal Input Junction Box
For connection of AC Input Power eg. from generator.(Available only when AC Transfer Switch option is fitted).
1000W - 1800W Models only.

