

User Manual

SR100/250/500/750-B/E

SmartChargers

Boost Chargers for lead acid batteries



Optional V/I meter shown



Z367

Safety

The user is responsible for ensuring that input and output wiring segregation complies with local standards and that in the use of the equipment, access is confined to operators and service personnel. A low resistance earth connection is essential to ensure safety and additionally, satisfactory EMI suppression (see below).

HAZARDOUS VOLTAGES EXIST WITHIN A POWER SUPPLY ENCLOSURE AND ANY REPAIRS MUST BE CARRIED OUT BY A QUALIFIED SERVICEPERSON.

Electrical Strength Tests

Components within the power supply responsible for providing the safety barrier between input and output are constructed to provide electrical isolation as required by the relevant standard. However EMI filtering components could be damaged as result of excessively long high voltage tests between input, output and ground. Please contact our technicians for advice regarding electric strength tests.

Earth Leakage

Where fitted, EMI suppression circuits cause earth leakage currents which may be to a maximum of 3.5mA.

Ventilation

High operating temperature is a major cause of power supply failures, for example, a 10°C rise in the operating temperature of a component will halve its expected life. Therefore always ensure that there is adequate ventilation for the equipment. Batteries in particular suffer shortened lifetimes if subjected to high ambient temperatures.

Water / Dust

Every effort must be made in the installation to minimise the risk of ingress of water or dust. Water will almost always cause instant failure. The effects of dust are slower in causing failure of electronic equipment but all electrical equipment should be cleaned free of any dust accumulation at regular intervals.

Electromagnetic Interference (EMI)

Switching power supplies and converters inherently generate electrical noise. All wiring should be as short as practicable and segregated from all equipment wiring which is sensitive to EMI. Residual noise can be reduced by looping DC wiring through ferrite cores (sleeves). These are most effective as close to the power supply as possible and as many turns of the wire taken through the core (+ and - in the same direction) as the core will accommodate.

External fuse protection

Fuses or circuit breakers must be used in all battery circuits to protect against short circuits. External fuses should be used for power supplies/ chargers even though they are usually internally protected.

Connection polarity

It is critical to check the polarity carefully when connecting DC devices even with models which have non-destructive reverse polarity protection.

Glossary of terms used in our user manuals

PSU = power supply unit

BCT = battery condition test

ECB = electronic circuit breaker

ELVD = electronic low voltage disconnect

RPP = reverse polarity protection

EMI = electromagnetic interference

SNMP = Simple Network Management Protocol

LAN = local area network

DOD = depth of discharge

Instructions

WARNINGS

1 STANDING LOADS

DO NOT use this Smartcharger if there is any standing load present, the Smartcharger will stay in boost mode and overcharge the batteries.

If the **Smartcharger** is permanently connected to equipment, please ensure that the boost voltage is within the operating range of the equipment.

2 TEMPERATURE SENSOR

The temperature sensor should be placed as close to the battery as possible. For units fitted with an over temperature cutout function, please ensure that the temperature sensor is placed on the batteries.

OPERATION

The mode of operation of your **SmartCharger** is determined by the firmware version code on the nameplate label, please refer to pages 6-7 for a list of the codes.

CONNECTION PROCEDURE

Turn mains power on.

Connect the positive (+) output of the charger to the positive terminal of the battery.

Connect the negative (-) output of the charger to the negative terminal of the battery.

The charging status is indicated by the LEDs according to the table on page 4 of this booklet.

INDICATION & CONTROLS (Note SR100B does have front panel switches)

BOOST: Pushing this button will force the charger into boost mode (if not already in boost)

FLOAT: Pushing this button will force the charger into a forced float mode. The charger will then stay in this mode until both mains power **and** the battery are disconnected.

STANDBY: Push this button to turn charger output off or on.

ALARM OUTPUTS (SR 250E, SR500E, SR750E versions)

Alarm relay de-energized states:

AUX: Float state (in the HV models terminals (1) & (2) are used to initiate a boost charge when shorted together.

MAINS FAIL: Loss of input power

BATT LOW: Battery low volts

AUX			MAINS FAIL			BATTERY LOW			EARTH
COM	NC	NO	COM	NC	NO	COM	NC	NO	
(1)	(2)								

LED INDICATION

All Models:

BOOST (red)	FLOAT (green)	STANDBY (red)	DESCRIPTION
*1 Occulting	Off	Off	Pre-boost state : Boost voltage level
On	Off	Off	Boost voltage mode
Off	Occulting	Off	Pre-float state: Float voltage level
Off	On	Off	Charger in float mode
Alarm Codes:			
SR250E, SR500E & SR750E:			
Flash	Flash-Flash	Off	*2 Mains/charger fail, Battery voltage OK
Flash-flash	Flash	Off	*2 Mains/charger fail, Battery voltage low
SR250B/E, SR500B/E, SR750B/E:			
Off	Off	On	Power on, charger in standby mode, battery voltage OK

Notes:

*1 Occulting = LED flashes with 'on' state longer than 'off' state

*2 These codes appear after the DBMFA (delay before mains fail alarm) time.

Alarm relay output states (only for SR250E, SR500E & SR750E)

'On' = relay energised

BOOST/FLOAT	MAINS FAIL	BATT LOW	DESCRIPTION
On	On	On	Pre-boost or Boost state : Boost voltage level
Off	On	On	Pre-float or Float state : Float voltage level
Off	On	On	Pre-forced float or forced float state: Float voltage level
Off	Off	On	Mains/charger fail or stand-by, Battery voltage OK
Off	Off	Off	Mains/charger fail or stand-by, Battery voltage low

Firmware Parameter Settings

The microprocessor firmware setting for your **SmartCharger** is shown on the following pages. Note that these settings are not user adjustable but can be changed by returning the **SmartCharger** to Innovative Energies.

		Ref. no:	
Parameter (settings at 20 degreesC)		Specified Settings	Default Settings
V float			2.3V/cell
V boost			2.45V/cell
Standing load (A) - maximum allowable			1% of I rated
Current limit (A)			I rated
Over temperature cutout , degrees C (only for Li-ion batteries)			NO
*Current initiated boost point (% of rated current, A)			15%
*Current terminated boost point (% of rated current, A)			10%
Microprocessor Settings			
Code	Description		
*SBS	Start in Boost State at charger start-up		YES
*CTB	Current Terminated Boost - allows termination of boost charge via the detection of a predefined value of charge current (default = 15% of max charge current)		YES
*CIB	Current Initiated Boost - allows initiation of boost charge via the detection of a predefined value of charge current (default = 10% of max charge current)		YES
*MRSB	Mains Return Start Boost - after the detection that mains has been restored to the charger a boost charge cycle will be initiated.		YES
PBT (minutes)	Pre-Boost State Time - the time the charger will always stay at the elevated boost voltage whenever an attempt is made to enter a boost charge cycle		1
BT (1-48 hours)	Boost Time - The maximum time the charger can spend in a boost charge cycle. If the charger is still in boost after this time it will enter the forced float state. Reset by turning mains off and on. The forced float state does not allow any further boost cycles unless initiated by user initiated boost button press.		24
PFT (minutes)	Pre Float Time - the time the charger will always stay at the float voltage whenever an attempt is made to enter a float charge cycle		1
RMFT (1-255 minutes)	Recall Mains Fail Time - maximum time of a mains fail where on the reoccurrence of mains the charger will resume charging in the mode as prior to the mains fail		10
MFT (1-24 hours)	Mains Fail Time - the time of a mains fail after which the charger will always restart with a boost cycle when mains reoccurs.		24
PFFT (1-255 minutes)	Pre Forced Float Time - the time the charger will always stay at the float voltage whenever an attempt is made to enter a forced float charge cycle		1
DBMFA (0.06-8.5 minutes)	Delay before mains fail alarm - the time before alarm activated on a mains failure ('E' versions)		5
	New SFBOOST .. code to be allocated (internal use only)		

* Always 'NO' for high voltage (64V and above) SR500/SR750 versions (auto boost not available)

* HV (high voltage) versions only

B = default version

Manual boost versions (LV)

CODE	A*	B	D	E	F	G	I	J	K	L	M	N	P*	Q	R
SBS	NO	YES	YES	YES	NO	NO	YES	NO	NO	YES	YES	YES	NO	YES	NO
CTB	NO	YES	YES	YES	YES	YES	YES	YES	YES	YES	YES	YES	NO	YES	NO
CIB	NO	YES	NO	YES	NO	NO	NO	NO	NO	YES	NO	YES	NO	NO	NO
MRSB	NO	YES	YES	YES	NO	NO	NO	NO	NO	YES	NO	YES	NO	YES	NO
PBT(min)	1	1	1	1	1	1	1	1	1	1	1	1	1	1	1
BT (hrs)	24	24	8	12	24	0.02	24	8	4	8	8	7	2	7	1
PFT (min)	1	1	1	1	1	1	1	1	1	10	1	1	1	1	1
RMFT(min)	10	10	10	10	240	240	255	10	1	24	255	10	10	10	70
MFT(hrs)	24	24	24	24	24	24	24	24	255	1	24	24	24	24	24
PFFT(min)	1	1	1	1	1	1	1	1	1	1	1	1	1	1	1
DBMFA (mins)	5	5	5	5	1	5	5	1	1	1	1	5	5	5	5

CODE	S	T	U	V	W	X	Y	Z	ZA	ZB	ZC	ZD	ZE	ZG	ZH
SBS	NO	YES	NO	NO	YES	YES	YES	YES	NO	NO	NO	NO	NO	YES	YES
CTB	YES	YES	NO	YES	YES	YES	YES	YES	NO	YES	NO	YES	NO	NO	NO
CIB	NO	NO	NO	NO	YES	YES	YES	NO	NO	NO	NO	NO	NO	NO	NO
MRSB	NO	YES	NO	NO	YES	YES	YES	YES	NO	YES	NO	NO	NO	NO	NO
PBT(min)	1	1	1	1	1	1	1	1	1	1	1	1	1	1	1
BT (hrs)	4	4	5	2	24	2	4	8	2	2	8	3	4	4	16
PFT (min)	1	1	1	1	1	1	1	1	1	1	1	1	1	1	1
RMFT(min)	1	10	255	255	10	10	10	10	10	10	70	255	10	255	255
MFT(hrs)	255	24	24	24	0	24	24	1	2	1	1	24	1	24	24
PFFT(min)	1	1	1	1	1	1	1	1	1	1	1	1	1	1	1
DBMFA (mins)	0.1	5	5	5	0	5	5	5	0.1	1	5	5	5	5	5

Notes:

G = all boost functions disabled, this firmware is used to obtain electronic reverse polarity protection

S = No LED flash codes on mains fail, all other functions unchanged

*HV versions available only in 500W and 750W models

* HV (high voltage) versions only

B = default version

Manual boost versions (LV)

CODE	ZI	ZJ	ZK	ZL	ZM	ZN	ZO	ZP	ZQ	ZR	ZS	ZT	ZU	ZV	ZW
SBS	YES	NO	NO												
CTB	YES	NO	NO												
CIB	YES	NO	NO												
MRSB	YES	NO	NO												
PBT(min)	1	1	1												
BT (hrs)	1	10	5												
PFT (min)	1	1	1												
RMFT(min)	10	10	255												
MFT(hrs)	24	24	24												
PFFT(min)	1	1	1												
DBMFA (mins)	5	5	5												

CODE															
SBS															
CTB															
CIB															
MRSB															
PBT(min)															
BT (hrs)															
PFT (min)															
RMFT(min)															
MFT(hrs)															
PFFT(min)															
DBMFA (mins)															



- 24 Month Warranty

Z367

- Fully automatic operation
- Designed to industrial standards
- Automatic temperature compensation
- Indefinite short circuit protection
- Operating state and fault indication
- Non-destructive reverse polarity protection
- Can safely be left permanently connected to battery, will maintain 'float' charge
- Fully programmable microprocessor control
- ISO9001 Design management system
- Designed and manufactured in NZ

The SR SmartCharger is designed to recharge your battery in the shortest practicable time with programmable parameters to suit your specific application.

SPECIFICATIONS All specifications are typical at nominal input, full load and at 20°C unless otherwise stated.

ELECTRICAL

Input Voltages	
Standard	180V - 264VAC 45 - 65Hz
Optional	88V - 132VAC 45 - 65Hz
Fusing / Protection	Internal AC input fuse
Isolation	1KV DC input - output / earth
Efficiency	≥ 85%
Inrush current	<30A, 1.8ms
Output Power	100W continuous (0 - 50°C)
Output Voltages	Refer model table
Voltage adj. range	Approx 95 - 105% of V nominal
Temp. Compensation	Temperature sensor on 1.7m lead with adhesive pad: -4mV / °C / cell ±10%
Current Limit	Straight line current limit profile (output side)
Output Protection	Automatic shutdown if battery leads reversed or short circuit on output
Line Regulation	<0.04% over input range
Load Regulation	<0.5% open circuit to 100% load
Noise	<0.3%
Transient response	200mV over / undershoot, load step 20 -100%, 400us settling time
Hold-up time	15 - 20 ms (nom. - max. Vin) without battery
OVP	Over-voltage protection on output at ~ 130% of nominal output voltage

STANDARDS

EMI	to CISPR 22 / EN55022 class A
Safety	to IEC950 / EN60950 / AS/NZS3260

FEATURES

LED Indication	BOOST: Red FLOAT: Green
Factory programmable parameters	- Start up in boost mode (Boost) - Current terminated boost (Yes) - Current initiated boost (Yes) - Start in boost on mains return (Yes) - Pre-boost state timer (1 minute) - Max boost charge time (24 hours) - Pre-float state timer (1 minute) - Resume prior state upon mains return timer (10 minutes) - Resume on boost charge upon mains return (24 hours) - Delay before mains fail recognition (5 mins)

PHYSICAL

AC Input Connection	IEC320 inlet socket (power cord supplied)
DC Output Connection	Plug-in style socket & mating screw terminal block: (max. wire 2.5mm ² / way)
Enclosure	Zinc plated steel /powder coated lid
Weight	0.94Kg
Mounting	Brackets for permanent fixture
Dimensions	146.5W x 177D x 62H mm

ENVIRONMENTAL

Operating temperature	0 - 50 °C ambient at full load De-rate linearly >50 °C to no load @ 70 °C
Storage temperature	-10 to 85 °C ambient
Humidity	0 - 95% relative humidity non -condensing
Cooling	Natural convection

100 Watt Three Stage Smartcharger (boost charger)

SR100B

STANDARD MODEL TABLE

MODELS	Output Voltage ¹ (float)	Output Voltage ¹ (max boost)	Output Current (continuous)	Min - Max Battery Size ²
SR100B12	13.8	14.7	6.7A	24 - 70 Ah
SR100B24	27.6	29.4	3.3A	12 - 40 Ah
SR100B36	41.4	44.1	2.2A	9 - 25 Ah
SR100B48	55.2	58.8	1.7A	6 - 20 Ah

¹ May be adjusted to suit battery specifications

² Check manufacturer's recommendations

MOUNTING DETAILS / DIMENSIONS

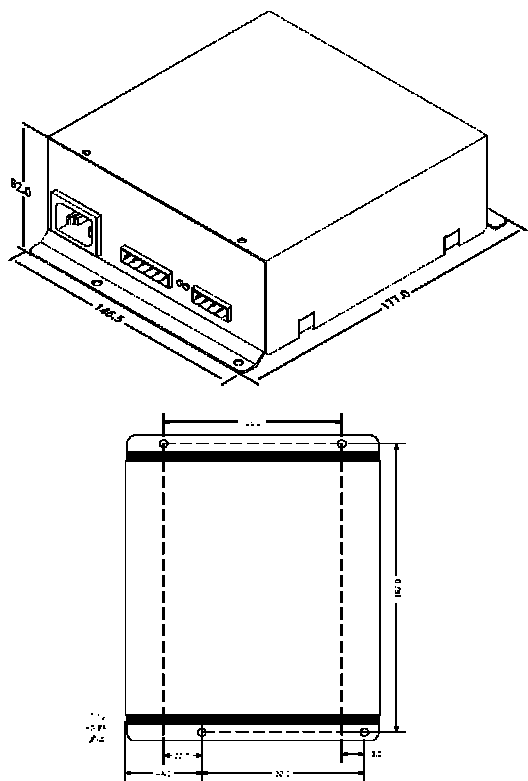

OPTIONS

Alarms	Not available with this model
Adjustable Parameters	All firmware parameters listed under features may be adjusted at time of ordering

MOUNTING OPTIONS

Distribution Panel	3RU x 19" rack with MCBs as required - DIST-PANEL
Rack mount	2RU x 19" rack - (rear connection) Code: SR-RM2U
Wall Mount Enclosure	Code: SEC-SR

WARNING

If the SmartCharger is connected to operating equipment during charging:

- equipment will be subjected to 1.22 times the nominal voltage.
- the standing load must be taken into account for the correct operation of the charger. Please contact our sales office if you have any standing load.

MODEL CODING AND SELECTION CHART

SR100B 12 T X G

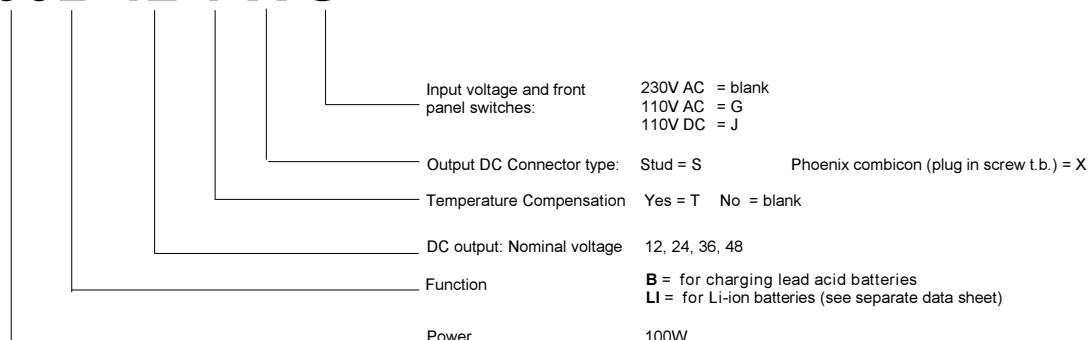



- Auto or Manual initiated boost charge
- Designed to industrial standards
- Automatic temperature compensation
- Short Circuit and reverse polarity protection
- Operating state and fault indication
- Fully programmable microprocessor control
- Can safely be left permanently connected to battery, will maintain 'float' charge
- Optional relay alarm outputs (SR250E)
- ISO9001 Design management system
- Designed and manufactured in NZ

The SR SmartCharger is designed to recharge your battery in the shortest practicable time with programmable parameters to suit your specific application.



Z367

- 24 Month Warranty

SPECIFICATIONS All specifications are typical at nominal input, full load and at 20°C unless otherwise stated.

ELECTRICAL	
Input Voltages standard	180V - 264V, 45 -65Hz
optional	88V - 132V , 45 -65Hz (internal link select)
Fusing / Protection	Internal AC input fuse
Isolation	1KV DC input - output / earth
Efficiency	≥ 85%
Inrush current	Soft start circuit
Output Power	250W continuous (0 - 50°C)
Output Voltages	Refer model table
Voltage adj. range	Approx 95 - 105% of V nominal
Temp. Compensation	Temperature sensor on 1.7m lead with adhesive pad: -4mV / °C / cell ±10%
Current Limit	Straight line current limit profile (output side)
Output Protection	Automatic shutdown if battery leads reversed or short circuit on output
Line Regulation	< 0.2% over AC input range
Load Regulation	< 0.4% open circuit to 100% load
Noise	< 1%
Drift	0.03% / °C
Hold -up time	15 - 20 ms (nom. - max. Vin) without battery
Thermal Protection	Yes
OVP	Over -voltage protection on output at ~ 130% of nominal output voltage

STANDARDS	
EMI	to CISPR 22 / EN55022 class A
Safety	to IEC950 / EN60950 / AS/NZS3260

FEATURES	
Switch/ LED Indication & functions	BOOST: Red (Push button to boost) FLOAT: Green (Push button to 'force' float) STANDBY: Red (Push button to turn output off/on) Refer to instruction manual for full list of LED Operation codes
Factory programmable parameters (default settings shown in brackets) Please note that some parameters are interdependent of each other.	- Start up in boost or float mode (Boost) - Current terminated boost (Yes) - Current initiated boost (Yes) - Start boost on mains return (Yes) - Pre -boost state timer 1 -255 minutes (1) - Max boost charge time 0 -48 hours (24) - Pre -float state timer 1 -255 minutes (1) - Resume prior state upon mains return timer 1-255 minutes (10) - Resume on boost charge upon mains return 0-255 hours (24) - Pre -forced float timer 1 -255 minutes (1) - Delay before mains fail recognition 4sec - 8.5minutes(5 minutes)

PHYSICAL	
AC Input Connection	IEC320 inlet socket (AC power cord supplied)
DC Output Connection	M6 brass stud, or 'Phoenix combicon' Plug-in style socket & mating screw terminal block: (max. wire 4mm ² / way)
Enclosure	Powder coated or zinc plated steel / anodised aluminium
Weight	1.7Kg

ENVIRONMENTAL	
Operating temperature	0 - 50°C ambient at full load De-rate linearly >50° C to no load @ 70° C
Storage temperature	-10 to 85 °C ambient
Humidity	0 - 95% relative humidity non -condensing
Cooling	Natural or fan cooled optional depending on model
Temperature Compensation	For accurate battery charging/float output voltage is automatically adjusted according to ambient temperature

250 Watt Three Stage Smartcharger (boost charger)

SR250B

incl. SR250E

STANDARD MODEL TABLE				
MODELS	Float Voltage* ¹	Boost Voltage * ¹	Output Current (continuous)	Min - Max Battery Size* ²
SR250B12	13.8	14.7	16.7A	65-200 Ah
SR250B24	27.6	29.4	8.3A	30-100 Ah
SR250B36	41.4	44.1	5.6A	22-70 Ah
SR250B48	55.2	58.8	4.2A	15-50 Ah



*¹ May be adjusted to suit battery specifications
*² Guidelines only. Please check manufacturer's recommendations.

MOUNTING DETAILS / DIMENSIONS

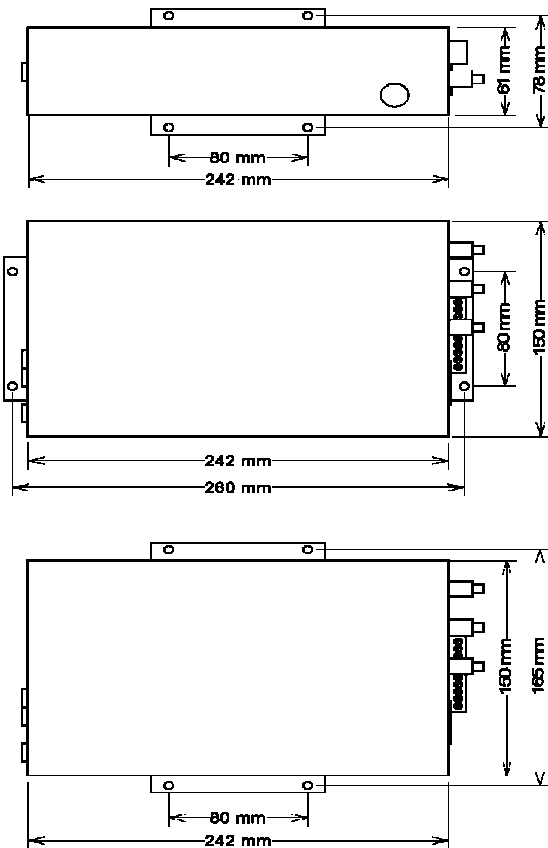

OPTIONS

- Alarm & boost/float indication relays*** (Order Code: replace suffix -B with -E)
 - Mains fail
 - Batt low (set at 1.83V/cell = 11, 22V, etc)
 - Boost/float
- Alarm Relay Contacts**
 - C - NO - NC full changeover
 - Rated 1A @ 50V DC or 32VAC
- Adjustable Parameters**
 - All firmware parameters listed under features

MOUNTING & DISTRIBUTION OPTIONS

- Rack mount** 2RU x 19" rack - (rear connection)
Code: **SR-RM2U**
 - Distribution Panel** 3RU x 19" rack with MCBs as required - **DIST-PANEL**
 - Wall Mount Enclosure** Code: **SEC-SR**
- For full information on these options please refer to respective data sheets.

WARNING

- If the SmartCharger is connected to operating equipment during charging:**
- equipment will be subjected to 1.22 times the nominal voltage.
 - the standing load must be taken into account for the correct operation of the charger. Please contact our sales office if you have any standing load.

MODEL CODING AND SELECTION CHART

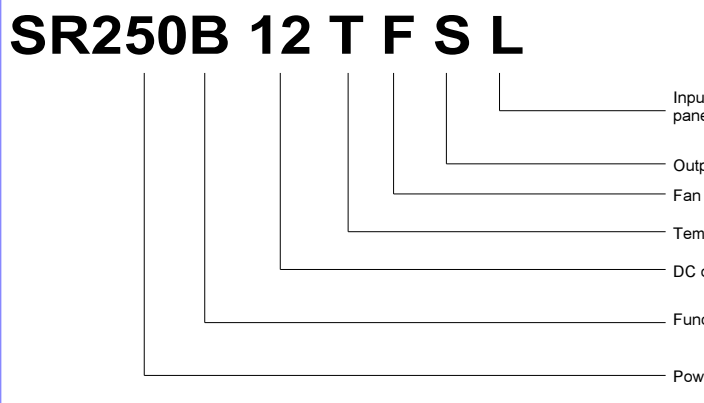



Optional V/I meter shown



Z367

- 24 Month Warranty

- Ideal for cyclic recharging applications
- Suitable for all types of lead acid batteries
- Fully automatic operation
- Fully programmable microprocessor control
- Boost charge can be programmed to be manually initiated (eg. for equalisation charge)
- Designed to industrial standards
- Automatic temperature compensation
- Short circuit and reverse polarity protection
- Operating state and fault indication
- Can safely be left permanently connected to battery, will maintain 'float' charge
- Optional relay alarm outputs (SR500E)
- Designed and manufactured in NZ

SPECIFICATIONS All specifications are typical at nominal input, full load and at 20°C unless otherwise stated.

ELECTRICAL	
Input voltage	230/240VAC (180 - 264), 50/60Hz 110/120VAC (88 - 132), 50Hz or 60Hz (to be specified at time of order)
Fusing / Protection	Internal AC input fuse
Isolation	1KV DC input - output / earth
Efficiency	≥ 85%
Inrush current	Soft start circuit
Output Power	500W continuous (0 - 50°C)
Output Voltages	Refer model table
Voltage adj. range	Approx 95 - 105% of V nominal
Temp. Compensation	Temperature sensor on 1.7m lead with adhesive pad: -4mV / °C / cell ±10%
Current Limit	Straight line current limit profile (output side)
Output Protection	Automatic shutdown if battery leads reversed or short circuit on output (except for high voltage models -fuse)
Line Regulation	< 0.2% over AC input range
Load Regulation	< 0.4% open circuit to 100% load
Noise	< 1%
Drift	0.03% / °C
Hold - up time	15 - 20 ms without battery
Thermal Protection	Yes
OVP	Over -voltage protection on output at ~ 130% of nominal output voltage
OVP	

STANDARDS	
EMI	to CISPR 22 / EN55022 class A
Safety	to IEC950 / EN60950 / AS/NZS3260

FEATURES	
Switch/ LED Indication & functions	BOOST: Red (Push button to boost) FLOAT: Green (Push button to 'force' float) STANDBY: Red (Push button to turn output off/on) Refer to instruction manual for full list of LED operation codes
Factory programmable parameters (default settings shown in brackets)* 1 Please note that some parameters are interdependent of each other.	- Start up in boost or float mode (Boost) - Current terminated boost (Yes) - Current initiated boost (Yes) - Start boost on mains return (Yes) - Pre -boost time (PBT) 1 -255 minutes (1) - Max boost time (BT) 1 -48 hours (24) - Pre -float timer 1 -255 minutes (1) - Resume prior state upon mains return timer 1-255 minutes (10) - Resume on boost charge upon mains return 1-24 hours (24) - Pre -forced float timer 1 -255 minutes (1) - Delay before mains fail recognition 4sec - 8.5minutes(5 minutes)
*1 except high voltage versions	

PHYSICAL	
AC Input Connection	IEC320 socket (AC power cord supplied)
DC Output Connection	M6 brass stud, or 'Phoenix combicon' plug-in style socket & mating screw terminal block: (max. wire 4mm ² / way)
Enclosure	Powder coated or zinc plated steel / anodised aluminium
Weight	4.3 Kg

ENVIRONMENTAL	
Operating temperature	0 to 50°C ambient at full load De-rate linearly >50° C to no load @ 70° C
Storage temperature	-10 to 85 °C ambient
Humidity	0 to 95% relative humidity non -condensing
Cooling	Natural or fan cooled depending on model
Temperature Compensation	For accurate battery charging/float output voltage is automatically adjusted according to ambient temperature

500 Watt Three Stage Smartcharger (boost charger)

SR500B

incl. SR500E

STANDARD MODEL TABLE

MODELS	Nominal Voltage	Float Voltage	Boost Voltage	Output Amps (continuous)	Battery Size Ah
SR500B12	12	13.8	14.7	34	130-600
SR500B24	24	27.6	29.4	17	65-300
SR500B36	36	41.4	44.1	11.3	44-200
SR500B48	48	55.2	58.8	8.5	30-150
SR500B72*	72	82.8	88.6	5.6	22-95
SR500B91 *	96	110.4	117.6	4.2	16-75
SR500B92 *	108	124.2	132.8	3.7	15-65
SR500B93 *	120	138.	147.0	3.4	13-60

* Note:

High voltage versions SR500B72, 91, 92, 93 have a manual boost function. Initiation of boost charge is by pushing the BOOST switch or relay contact. Termination of boost charge is by manual push button (FLOAT or STANDBY) or by the time set by the internal timer (BT setting). They do not have a current terminated boost function.

These versions have **Mains Fail** and **Battery Low** alarms as standard but no boost/float indication relay.

MOUNTING DETAILS / DIMENSIONS

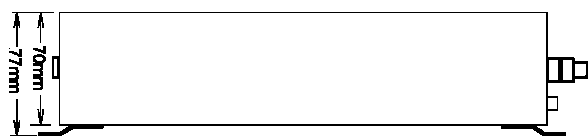
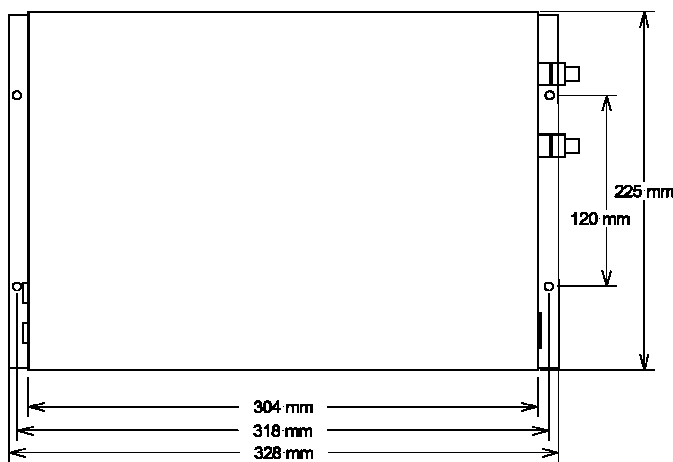

DIMS: 225W x 77H (incl. feet) x 340D

OPTIONS

Alarms & boost/float indication relays*
(Order Code: replace suffix -B with -E)

- **Mains fail**
- **Batt low** (set at 1.83V/cell = 11, 22V, etc)
- **Boost/float** (see * Note above)

Alarm Relay Contacts

C - NO - NC full changeover
Rated 1A @ 50V DC or 32VAC

Output Volts

May be adjusted to suit battery specifications

Mode of Operation

All firmware parameters listed under features

MOUNTING & DISTRIBUTION OPTIONS

Rack mount

2RU x 19" rack - (rear connection)
Code: **SR-RM2U**

Distribution Panel

3RU x 19" rack with MCBs as required -
DIST-PANEL

Wall Mount Enclosure

Code: **SEC-SR**

For full information on these options please refer to respective data sheets.

WARNING

If the SmartCharger is connected to operating equipment during charging:

1. equipment will be subjected to 1.22 times the nominal voltage.
2. the standing load must be taken into account for the correct operation of the charger. Please contact our sales office if you have any standing load.

MODEL CODING AND SELECTION CHART

SR500B 12 T F S L +Int-Meter

(with Volt/ Amp Meter) No = blank

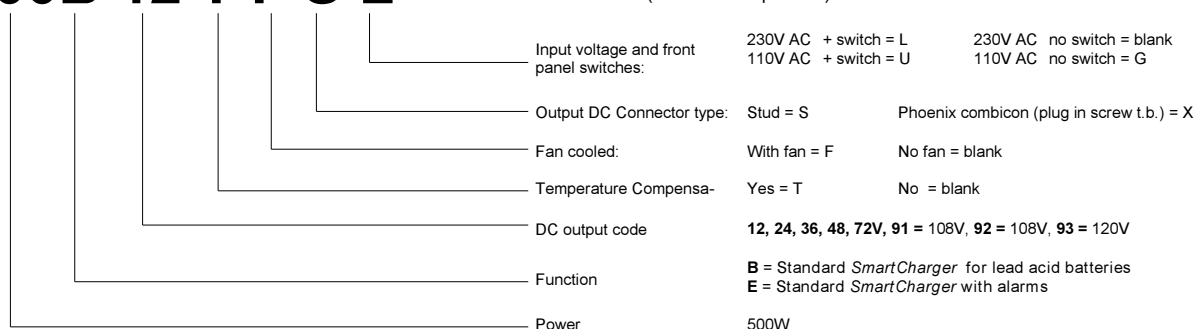



Optional V/I meter shown



Z367

- 24 Month Warranty

- Ideal for cyclic recharging applications
- Suitable for all types of lead acid batteries
- Fully automatic operation
- Fully programmable microprocessor control
- Boost charge can be programmed to be manually initiated (eg. for equalisation charge)
- Designed to industrial standards
- Automatic temperature compensation
- Short circuit and reverse polarity protection
- Operating state and fault indication
- Can safely be left permanently connected to battery, will maintain 'float' charge
- Optional relay alarm outputs (SR750E)
- Designed and manufactured in NZ

SPECIFICATIONS All specifications are typical at nominal input, full load and at 20°C unless otherwise stated.

ELECTRICAL		FEATURES	
Input voltage	230/240VAC (180 - 264), 50/60Hz 110/120VAC (88 - 132), 50Hz or 60Hz (to be specified at time of order)	Switch/ LED Indication & functions	BOOST: Red (Push button to boost) FLOAT: Green (Push button to 'force' float) STANDBY: Red (Push button to turn output off/on) Refer to instruction manual for full list of LED operation codes
Input protection	Internal fuse	Factory programmable parameters	- Start up in boost or float mode (Boost) - Current terminated boost (Yes) - Current initiated boost (Yes) - Start boost on mains return (Yes)
Output protection	Automatic shutdown if battery leads reversed	(default settings shown in brackets)* ¹	- Pre-boost time (PBT) 1 -255 minutes (1) - Max boost time (BT) 1 -48 hours (24) - Pre-float timer 1 -255 minutes (1) - Resume prior state upon mains return timer 1-255 minutes (10) - Resume on boost charge upon mains return 1-24 hours (24)
Current limit	Constant current limit on overload & short circuit	* ¹ except high voltage versions	- Pre -forced float timer 1 -255 minutes (1) - Delay before mains fail recognition 4sec - 8.5minutes(5 minutes)
Isolation	1KV DC input - output / earth	PHYSICAL	
Efficiency	≥ 85%	AC Input connector	IEC320 socket (AC power cord supplied)
Inrush current	Soft start	DC Connections	M6 brass stud or plug -in socket with screw terminals
Output power	750W	Enclosure	Powder coated steel
Output voltages	Refer to model table	Temperature sensor	1.7m lead with adhesive pad
Voltage adj. range	Approx 95 - 105% of V nominal	Weight	4.3 Kg
Temp. compensation	Output voltage compensated at -4mV / °C / cell	ENVIRONMENTAL	
Line regulation	<0.2% over input range	Operating temperature	0 - 50°C ambient at full load De-rate linearly >50° C to no load @ 70° C
Load regulation	<0.4% open circuit to 100% load	Storage temperature	-10 to 85 °C ambient
Noise	<0.1%	Humidity	0 - 95% relative humidity non -condensing
OVP	Over-voltage protection on output at ~ 130% of nominal output voltage	Cooling	Fan cooled
Thermal protection	Yes, self resetting	STANDARDS	
		EMI	to CISPR 22 / EN55022 class A
		Safety	to IEC950 / EN60950 / AS/NZS3260

750 Watt Three Stage Smartcharger (boost charger)

SR750B

incl. SR750E

STANDARD MODEL TABLE

MODELS	Nominal Voltage	Float Voltage	Boost Voltage	Output Amps (continuous)	Battery Size Ah
SR750B12	12	13.8	14.7	50	200-900
SR750B24	24	27.6	29.4	25	100-450
SR750B36	36	41.4	44.1	16.7	66-300
SR750B48	48	55.2	58.8	12.5	50-220
SR750B72*	72	82.8	88.6	6	27-120
SR750B91 *	96	110.4	117.6	6.2	25-110
SR750B92 *	108	124.2	132.8	5.6	22-100
SR750B93 *	120	138.0	147.0	5	20-90

* Note:

High voltage versions **SR750B72, 91, 92, 93** have a manual boost function. Initiation of boost charge is by pushing the BOOST switch or relay contact. Termination of boost charge is by manual push button (FLOAT or STANDBY) or by the time set by the internal timer (BT setting). They do not have a current terminated boost function.

These versions have **Mains Fail** and **Battery Low** alarms as standard but no boost/float indication relay.

MOUNTING DETAILS / DIMENSIONS

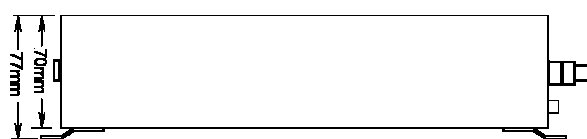
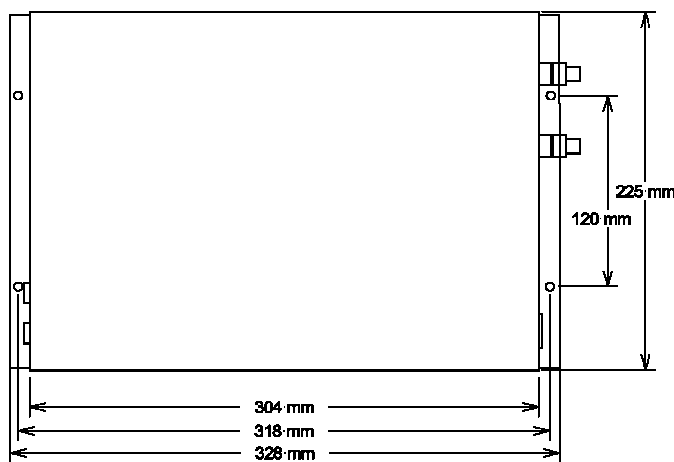

DIMS: 225W x 77H (incl. feet) x 340D

OPTIONS

Alarm & boost/float indication relays

- **Mains fail**
- **Batt low** (set at 1.83V/cell = 11, 22V, etc)
- **Boost/float** (see * Note above)

Alarm relay contacts

C - NO - NC full changeover
Rated 1A @ 50V DC or 32VAC

Output volts

May be adjusted to suit battery specifications

Mode of operation

All firmware parameters listed under features may be adjusted at time of ordering

Internal V/I meter

Add code: **+INT-METER**

Mounting options:

19" rack mount

2U sub rack available, Code: **SR-RM2U**
Optional V/I meter, Code: **SR-METER**

Wall mount enclosure

PSU may be fitted into enclosure with MCBs and terminals. Code: **SEC-SR**

WARNING

If the *SmartCharger* is connected to operating equipment during charging:

1. equipment will be subjected to 1.22 times the nominal voltage.
2. the standing load must be taken into account for the correct operation of the charger. Please contact our sales office if you have any standing load.

MODEL CODING AND SELECTION CHART

SR750B 12 T F S L

