

### 5 Watts

- Compact Size
- Medical Approvals
- 2 MOPP
- Single Outputs from 3.3 to 48 V
- PCB Mount
- Encapsulated & Open Frame
- Class II
- Peak Load Capability
- 3 Year Warranty



#### Dimensions:

EME05:  
1.50 x 1.00 x 0.60" (36.1 x 25.4 x 15.2 mm)  
EME05-P:  
1.40 x 0.94 x 0.69" (35.6 x 23.7 x 17.6 mm)

The EME05 is a series of open frame and encapsulated AC-DC single output power supplies designed for medical applications. The series provides two mechanical options including open frame and encapsulated PCB mount. With approvals to world-wide medical safety standards, compliance with class B for both conducted and radiated emissions and a 130%, 30s peak load capability, these class II isolation parts benefit system designers with easy integration into the latest healthcare products and applications.

#### Models & Ratings

Output Power	Output Voltage	Output Current		Model Number <sup>(2)</sup>
		Nominal	Peak <sup>(1)</sup>	
5 W	3.3 VDC	1510 mA	1960 mA	EME05US03
5 W	5.0 VDC	1000 mA	1300 mA	EME05US05
5 W	9.0 VDC	555 mA	722 mA	EME05US09
5 W	12.0 VDC	416 mA	541 mA	EME05US12
5 W	15.0 VDC	333 mA	433 mA	EME05US15
5 W	24.0 VDC	208 mA	270 mA	EME05US24
5 W	36.0 VDC	138 mA	180 mA	EME05US36
5 W	48.0 VDC	104 mA	135 mA	EME05US48

#### Notes

1. Peak load lasting <30 s with a maximum duty cycle of 10%, average output power not to exceed nominal.
2. For Open Frame version add suffix -P to model number, e.g. EME05US12-P.

#### Summary

Characteristic	Minimum	Typical	Maximum	Units	Notes & Conditions
Input Voltage Range	85		264	VAC	Derate from 100% at 90 VAC to 90% at 85 VAC
No Load Input Power			0.3	W	
Efficiency	72		86	%	
Operating Temperature	-25		+70	°C	Derate linearly from 100% at +50 °C to 50% at +70 °C
EMC	EN55011 Level B Conducted & Radiated, EN601000-3-2, EN61000-3-3, EN60601-1-2				
Safety Approvals	EN60601-1, ANSI/AAMI ES 60601-1, IEC 60601-1				

### Input

Characteristic	Minimum	Typical	Maximum	Units	Notes & Conditions
Input Voltage Range	85		264	VAC	
Input Frequency	47		63	Hz	
Input Current - Full Load		0.10/0.06		A rms	At 115/230 VAC
No Load Input Power			0.3	W	
Inrush Current			40	A	At 230 VAC
Earth Leakage Current					Class II construction no earth
Input Protection	Internal T1.0 A/250 VAC fuse fitted in line and neutral				

### Output

Characteristic	Minimum	Typical	Maximum	Units	Notes & Conditions
Output Voltage	3.3		48	VDC	
Initial Set Accuracy			±1	%	
Minimum Load	0			A	No minimum load required
Start Up Delay			2	s	
Start Up Rise Time			14	ms	
Hold Up Time	12			ms	at full load and 115 VAC
Line Regulation			±0.5	%	
Load Regulation			±1	%	
Transient Response			4	%	Deviation, recovery within 1% in less than 500 µs for a 25% load change
Ripple & Noise			50	mV pk-pk	3.3-5 V versions, 20 MHz bandwidth
			90	mV pk-pk	9 V versions, 20 MHz bandwidth
			120	mV pk-pk	12-15 V versions, 20 MHz bandwidth
			200	mV pk-pk	24-48 V versions, 20 MHz bandwidth
Overvoltage Protection	115		140	% Vnom	Recycle input to reset
Overload Protection	130		200	%	
Short Circuit Protection					Trip & Restart (hiccup mode)
Temperature Coefficient			0.05	%/°C	

### General

Characteristic	Minimum	Typical	Maximum	Units	Notes & Conditions
Efficiency		80		%	
Isolation: Input to Output	4000			VAC	2 x MOPP
Switching Frequency		130		kHz	
Power Density			5.5	W/in <sup>3</sup>	
Mean Time Between Failure		>400		kHrs	MIL-HDBK-217F, +25 °C GB
Weight		0.03 (14)		lb (g)	Open frame versions (-P)
		0.053 (24)		lb (g)	Encapsulated version

### Efficiency Graphs

EME05US12

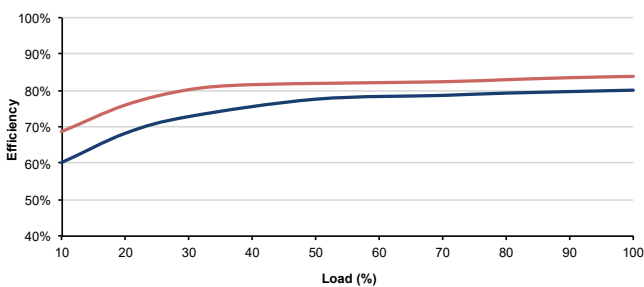

EME05US24

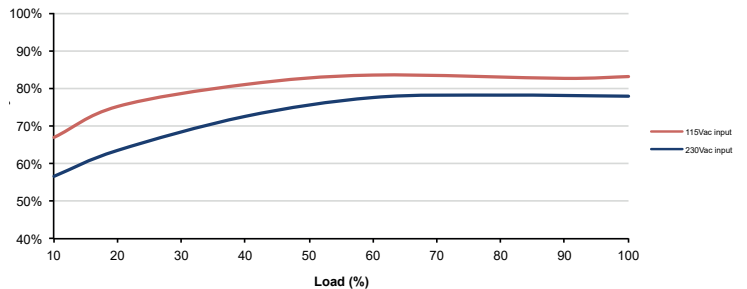

### Environmental

Characteristic	Minimum	Typical	Maximum	Units	Notes & Conditions
Operating Temperature	-25		+70	°C	Derate linearly from 100% at +50 °C to 50% at +70 °C
Storage Temperature	-40		+85	°C	
Cooling					Convection-cooled
Humidity			95	% RH	Non-condensing
Operating Altitude			3048	m	
Shock	IEC68-2-27, 30 g, 11 ms half sine, 3 times in each of 6 axes				
Vibration	IEC68-2-6, 2 g, 10 Hz to 500 kHz, 10 mins/cycle, 60 mins each cycle				

### EMC: Emissions

Phenomenon	Standard	Test Level	Criteria	Notes & Conditions
Conducted	EN55011	Class B		
Radiated	EN55011	Class B		
Harmonic Current	EN61000-3-2			Class A
Voltage Flicker	EN61000-3-3			

### EMC: Immunity

Phenomenon	Standard	Test Level	Criteria	Notes & Conditions
Medical Device EMC	IEC60601-1-2	Ed 4.0: 2014	As below	
ESD	EN61000-4-2	±8kV contact, ±15kV air discharge	A	
Radiated	EN61000-4-3	10 V/m	A	80% mod, 80 MHz - 2.7 GHz plus discrete communication proximity field frequencies
EFT	EN61000-4-4	3	A	
Surge	EN61000-4-5	2	A	
Conducted	EN61000-4-6	10 Vrms	A	
Magnetic Fields	EN61000-4-8	30 A/m	A	
Dips and Interruptions	EN60601-1-2 (100 VAC)	70% U <sub>r</sub> (70 VAC) for 500 ms	A	Load de-rated to 50%
		40% U <sub>r</sub> (40 VAC) for 100 ms	A	
		<5% U <sub>r</sub> (0 VAC) for 10 ms	A	
		<5% U <sub>r</sub> (0 VAC) for 5000 ms	B	
	EN60601-1-2 (240 VAC)	70% U <sub>r</sub> (168 VAC) for 500 ms	A	
		40% U <sub>r</sub> (96 VAC) for 100 ms	A	
		<5% U <sub>r</sub> (0 VAC) for 10 ms	A	
		<5% U <sub>r</sub> (0 VAC) for 5000 ms	B	

### Safety Approvals

Safety Agency	Safety Standard	Notes & Conditions
CB Report	IEC60601-1 Including Risk Management	Medical
UL	ANSI/AAMI ES 60601-1:2005 & CSA C22.2, No.60601-1:08	Medical
TUV	EN60601-1	Medical

Means of Protection	Category
Primary to Secondary	2 x MOPP (Means of Patient Protection) IEC60601-1 Ed 3.1

### Mechanical Details

#### Encapsulated

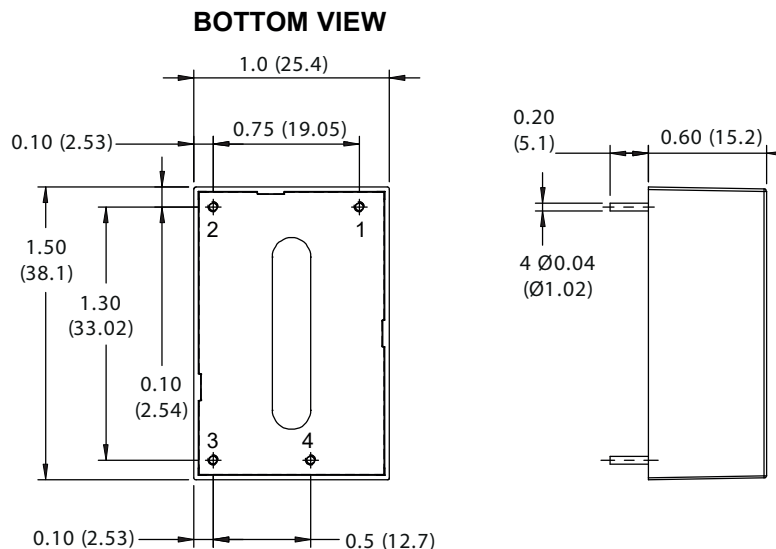

#### Open Frame (-P)

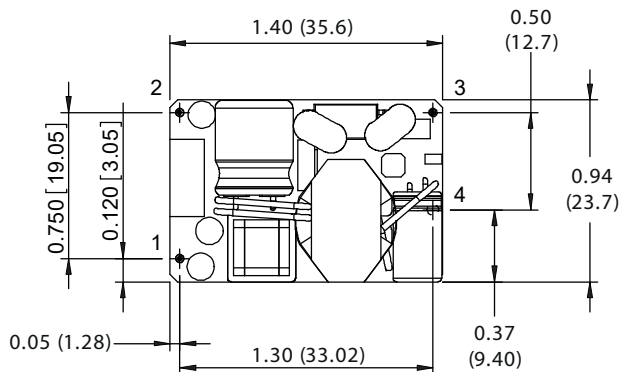

Pin Connections	
Pin	Single
1	ACN
2	ACL
3	-Vout
4	+Vout

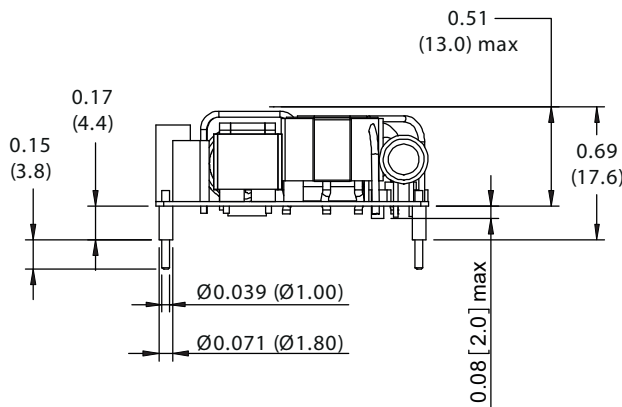

#### Notes

- Dimensions in inches (mm).
- Weight: Open frame versions (-P): 0.03 lbs (14 g)  
Encapsulated: 0.053 lbs (24 g)

- Tolerances: x.xx = ± 0.02 (x.x = ± 0.5)  
x.xxx = ± 0.01 (x.xx = ± 0.25)