

240 Watts

- Ultra Slim Design - 45 mm
- 150% Peak Load for 3 seconds
- Ambient Operation from -25 °C to +70 °C
- Full Load at 60 °C
- High Efficiency - Up to 94%
- Volt-Free Contact for DC OK
- Selectable Parallel Operation
- 85 to 264 VAC Operation
- 3 Year Warranty



Dimensions:

DSR240:

1.77 x 4.88 x 4.69" (45.0 x 124.0 x 119.0 mm)

Models & Ratings

Output Voltage	Output Power	Output Voltage Trim ⁽³⁾	Output Current	Peak Current ⁽²⁾	Typical Efficiency ⁽¹⁾	Model Number
24 V	240 W	24.0-28.0 V	10.0 A	1.5 A	94%	DSR240PS24
48 V	240 W	48.0-56.0 V	5.0 A	7.5 A	93%	DSR240PS48

Notes

1. Typical efficiency at 230 VAC and full load.
2. Peak current is for a maximum of 3 s, see Application Notes. Average power is not to exceed nominal output power.
3. Output current should be limited so that nominal output power is not exceeded.

Mechanical Details

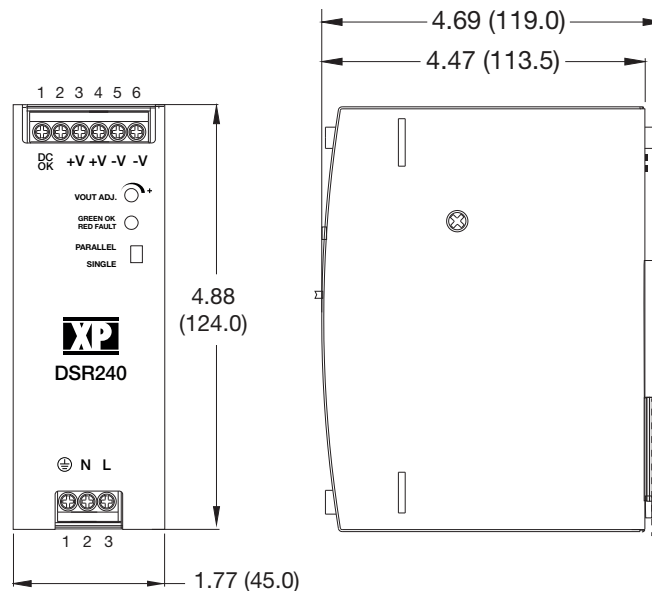

Pin Connector		
Conn	Pin	Designation
AC I/P	1	Ground
	2	N
	3	L
DC O/P	1	DC OK
	2	DC OK
	3	+Vout
	4	+Vout
	5	-Vout
	6	-Vout

Notes

1. All dimensions in inches (mm)
2. Weight: 1.68 lbs (760g)
3. Tolerance: ±0.02 in (±0.5 mm)

Input

Characteristic	Minimum	Typical	Maximum	Units	Notes & Conditions
Input Voltage - Operating	85		264	VAC	
Input Frequency	47	50/60	63	Hz	
Power Factor		0.95			At 230 VAC. Conforms to EN61000-3-2 Class A
Input Current - Full Load		2.3/1.13		A	115/230 VAC
Inrush Current			20/40	A	At 115/230 VAC. Cold Start, 25 °C
Earth Leakage Current			1.0	mA	At 264 VAC, 60 Hz
Input Protection	T5.0 A / 250 V internal in-line fuse				

Output

Characteristic	Minimum	Typical	Maximum	Units	Notes & Conditions
Output Voltage - V1	24		48	VDC	See Models and Ratings table
Initial Set Accuracy			±1	%	At 100% load
Output Voltage Adjustment				%	See Models and Ratings table
Minimum Load	0			A	No minimum load required
Start Up Delay			500	ms	At 100 VAC
Hold Up Time	20			ms	At full load
Line Regulation			±0.5	%	
Load Regulation			±1	%	
Transient Response - V1			5	%	Recovery within 1% in less than 200 µs for a 50% step load change at 0.2 A/µs
Ripple & Noise			240/480	mV pk-pk	24 V/48 V models. Measured at 20 MHz bandwidth 0-70°C
			480/480		24 V/48 V models. Measured at 20 MHz bandwidth -25-0°C
Overvoltage Protection	15		18	V	12 V model
	29		33	V	24 V model
	58		65	V	48 V model
Overload Protection	110		150	%	Trip & restart. See application note.
Short Circuit Protection					Trip & restart (hiccup mode) for 5 cycles then latch. Recycle AC to reset.
Thermal Protection		100 ±5		°C	Measured internally auto recovery
Temperature Coefficient			0.03	%/°C	

General

Characteristic	Minimum	Typical	Maximum	Units	Notes & Conditions
Efficiency		93		%	See Models & Ratings table
Isolation: Input to Output Input to Ground Output to Ground	3000			VAC	
	2500			VAC	
	500			VAC	
Switching Frequency		65		kHz	PFC, Fixed
	60		300	kHz	Main converter, Variable
DC OK Signal	Volt free contacts rated at 60 VDC/0.3 A, 30 VDC/1.0 A or 30 VAC/0.3 A (resistive load)				
Output LED	Green LED to indicate output on.				
Mean Time Between Failure	300			kHrs	MIL-HDBK-217F, +25 °C GB
Weight		1.68 (760)		lb (g)	

Environmental

Characteristic	Minimum	Typical	Maximum	Units	Notes & Conditions
Operating Temperature	-25		+70	°C	See derating curve in Application Notes
Storage Temperature	-40		+85	°C	
Cooling					Natural convection
Operating Humidity	20		95	%RH	Non-condensing
Operating Altitude			5000	m	
Shock		4		g	IEC68-2-27, 22 ms half sine, 3 times in each of 6 axes
Vibration		2		g	IEC68-2-6, 10-500 Hz, 10 mins/sweep. 60 mins for each of 3 axes

EMC: Emissions

Phenomenon	Standard	Test Level	Criteria	Notes & Conditions
Conducted	EN55032	Class B		
Radiated	EN55032	Class B		
Harmonic Current	EN61000-3-2	Class A		
Voltage Fluctuations	EN61000-3-3			

EMC: Immunity

Phenomenon	Standard	Test Level	Criteria	Notes & Conditions
ESD Immunity	EN61000-4-2	6 kV	A	Contact
		8 kV		Air Discharge
Radiated Immunity	EN61000-4-3	10 V/m	A	
EFT/Burst	EN61000-4-4	3	A	
Surges	EN61000-4-5	Installation class 3	A	
Conducted	EN61000-4-6	10 V	A	
Magnetic Fields	EN61000-4-8	4	A	
Dips and Interruptions	EN55024	Dip: 30%, 10 ms	A	
		Dip: 60%, 100 ms	A/B	High Line/Low Line
		Dip: 100%, 5000 ms	B	

Safety Approvals

Safety Agency	Safety Standard	Notes & Conditions
UL	UL508/UL60950	Industrial Control Equipment/Information Technology
TUV	EN60950-1	Information Technology
CB	IEC60950-1	Information Technology

Mechanical Details

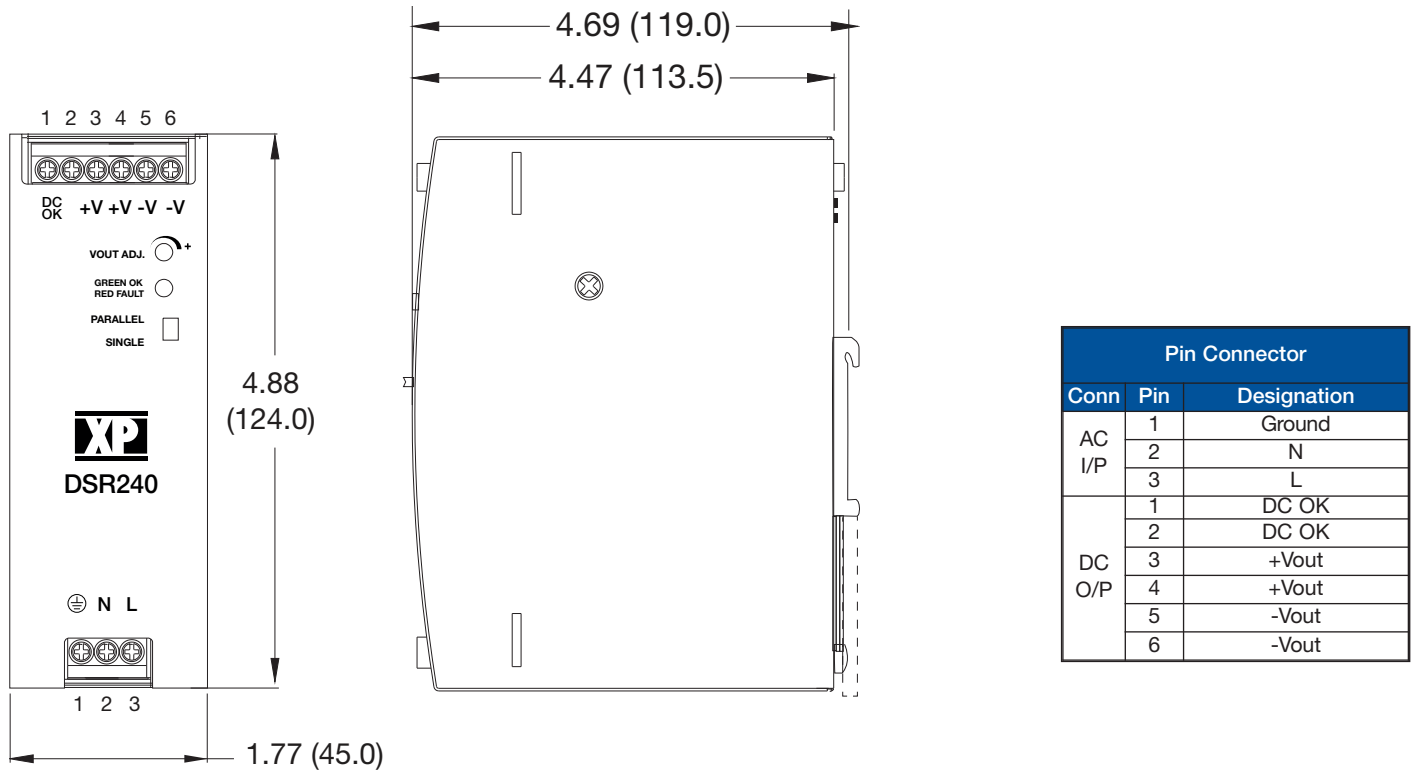

Notes

1. All dimensions in inches (mm)
2. Weight: 1.68 lbs (760g)

3. Tolerance: ± 0.02 in (± 0.5 mm)

Application Notes

Derating Curves

DSR240PS24

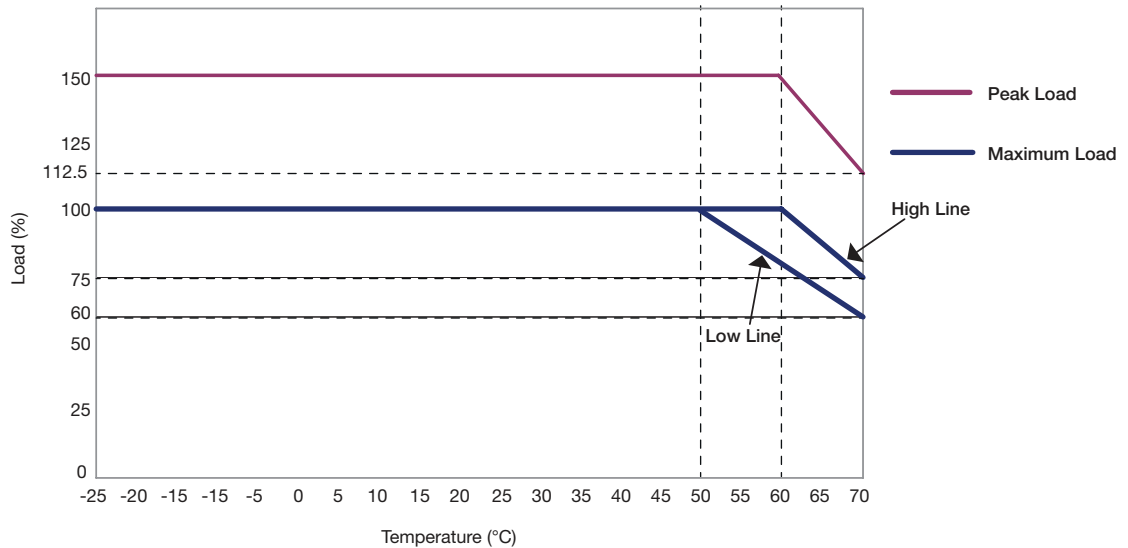

Application Notes

Derating Curves

DSR240PS48

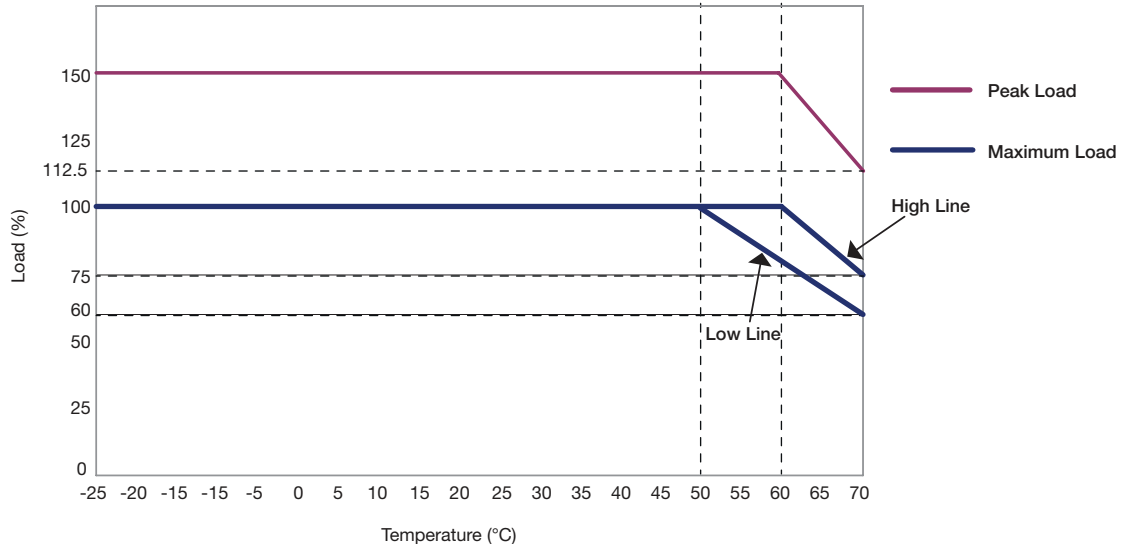

DC OK

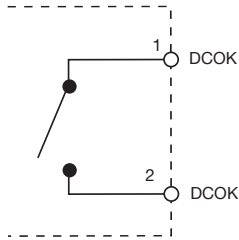

Open = Output fail, if voltage drops below 80% of nominal
 Closed = Output good

Contact Rating: 0.3 A at 60 VDC, 1.0 A at 30 VDC, 0.5 A at 30 VAC.
 500 VDC isolation to output.

Peak Load and Overload

A peak load can be used for a certain period after which the output goes into overload mode. Overload operation is trip and restart. The peak load duration depends on the value of the load, e.g. a peak load of 150% can be taken for approximately 3s. After this time the output will turn off for approximately 7s before turning back on.

If the load has reduced to 100% or less than normal operation is resumed. If the load remains at 150% then the output is maintained for a further 3s before turning off for 7s. See example plot below.

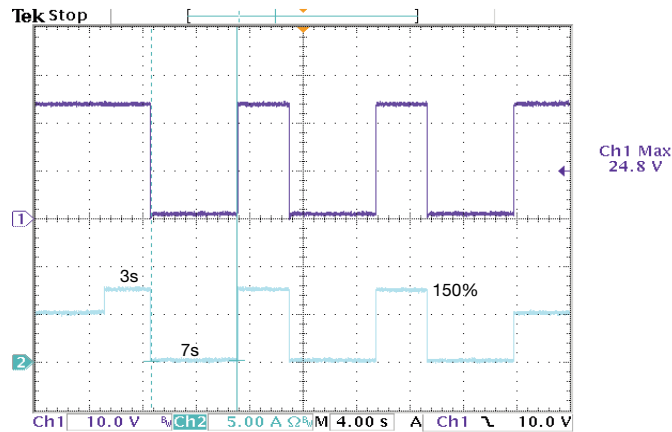

If the peak load is less than 150%, the duration of the peak can be longer than 3s before the output turns off, for example, a peak load of 130% could typically be taken for up to 13s and a peak load of 140% could typically be taken for up to 5s. The off duration is always approximately 7s.

Average power is not to exceed nominal output power.