

LH Open Stack Series 4 kW Regulated High Voltage DC Power Supplies

200 kV to 500 kV
CE Compliant

Parallelable up to 20 kW

Fully RoHS Compliant

The LH open stack family are sophisticated 4 kW power supplies with extremely low ripple and noise. They are air insulated fast response units with tight regulation. Please refer to Technology > Applications page on our web site for typical applications.

The LH Series, when configured with the 400 VAC input option, are fully compliant with the following European Directives:

- EN61010/ IEC61010, Safety
- EN61000-6-4, Conducted and Radiated Emissions
- EN61000-6-2:2005, Conducted and Radiated Immunity
- 2011/65/EU, Restriction of the use of Hazardous Substances (RoHS)

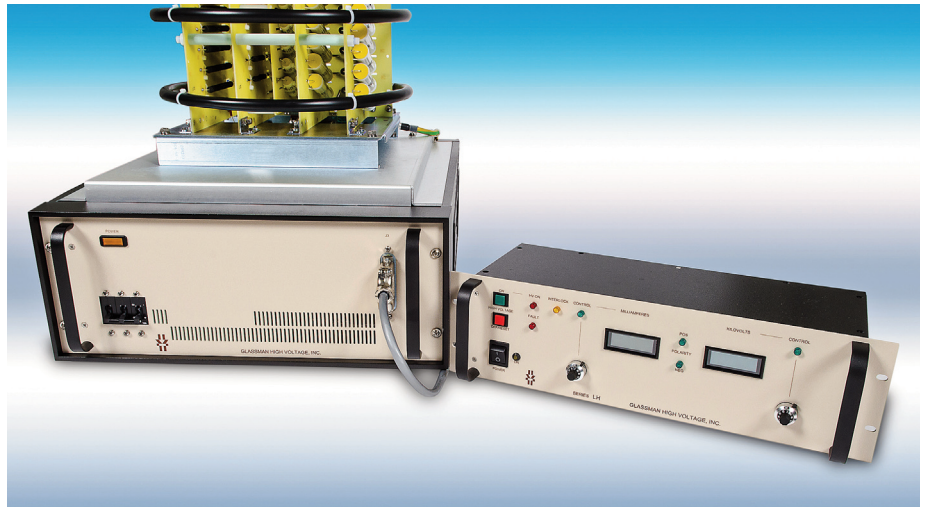

Models from 0 to 200 kV through 0 to 500 kV. 4 kW system shown above (and bottom left).

LH open stack series models consist of a rack style driver chassis, a high voltage stack assembly, and a remote control unit. The driver chassis is provided in a cabinet which is 9.10" H X 25.06" D. The remote control unit is 5.218" H X 19.00" W X 6.625" D.

Features:

Arc Quench. The HV output is inhibited for a short period after each load arc to help extinguish the arc.

Arc Sensing. Internal circuitry constantly senses and integrates arcs that occur over a given time. In the event that a load arcing problem develops, the power supply will cycle off, then automatically restart.

Embedded Microcontroller Control. Integral RS-232, USB and optional Ethernet communications provide remote control program and monitor.

Air Insulated. The LH Series features "air" as the primary dielectric medium. No oil or encapsulation is used to impede serviceability, or increase weight.

Low Ripple. Typically, ripple is less than 0.1% peak to peak of rated voltage at full load.

Parallelable. One master supply and up to 4 slave supplies provide a maximum of 12 - 20 kW depending on kV.

Pulse-Width Modulation. Off-the-line pulse-width modulation provides high efficiency and a reduced parts count for improved reliability.

Constant Voltage/Constant Current Operation. Automatic crossover from constant-voltage to constant-current regulation provides protection against overloads, arcs, and short circuits.

Constant Current/Current Trip. A rear panel selector switch on the remote chassis allows selection of either current mode.

Tight Regulation. Voltage regulation is better than 0.005% for allowable line and load variations. Current regulation is better than 0.1% from short circuit to rated voltage.

Warranty. All power supplies are warranted for one year. A formal warranty statement is available.

Specifications

Specifications apply from 5% to 100% rated voltage. (Operation is guaranteed down to zero voltage with a slight degradation of performance.)

Input: 187-228 V RMS, 3 ϕ , 48-63 Hz, 5500 VA maximum at full load. Less than 16A/ ϕ at 208 VAC. A five position terminal block with protective cover is provided on the rear panel of the driver chassis. **Mains service must be protected with fuses or circuit breakers with a maximum rating of 100 A for 200/208 VAC models & 60 A for 400 VAC models.**

Efficiency: Typically 80% at full load.

Output: Continuous stable adjustment from 0 to rated voltage or current by panel mounted 10-turn potentiometers with 0.05% resolution, or by external 0 to 10 V signals is provided. Repeatability better than 0.1% of setting. Voltage accuracy is 0.5% of setting + 0.2% of rated.

Static Voltage Regulation: Better than +/- 0.005% for specified line variations and 0.005% for no load to full load variations.

Current Regulation: Better than 0.1% from short circuit to rated voltage at any load condition, when in current regulation mode.

When in current trip mode the HV output will disable and latch off when the load current reaches the programmed current level. Reset is accomplished by either cycling the AC power or HV ON/OFF buttons or by toggling the HV enable signal. A switch located on the rear panel of the remote control chassis allows the selection of current limit or current trip operation.

Voltage monitor: 0 to 10V equivalent to 0 to rated voltage. Accuracy, 0.5% of reading + 0.2% of rated. Impedance is 10 K Ω .

Current monitor: 0 to 10V equivalent to 0 to rated current. Accuracy, 1% of reading + 0.05% of rated. Reverse polarity models: 1% of reading + 0.1% of rated. Impedance is 10 K Ω .

Stored Energy: Stored energy varies with output voltage and is tabulated in the models chart.

Ripple: Ripple con-

sists of two major components, inverter switching frequency components and line frequency related components. The inverter frequency component is dependent on the amount of load current drawn. The line frequency related component is determined by the amount of power delivered to the load. The maximum values for both components are specified in the models chart.

Stability: 0.01% per hour after 1/2 hour warm-up, 0.05% per 8 hours.

Voltage Rise/Decay Time Constant: 400 ms typical using either the HV ON switch or remote programming with a minimum 2.7 mA resistive load. Parallel systems require an additional 2.7 mA load per slave.

Temperature Coefficient: 0.01%/°C.

Ambient Temperature: -20 to +40° C, operating, -40 to +85° C storage.

Protection: Automatic current regulation protects against all overloads, including arcs and short circuits. Thermal switches and RPM sensing fans protect against thermal overload. Fuses, surge-limiting resistors and low energy components provide ultimate protection.

Arc Quench: An arc quench feature provides sensing of each load arc and quickly inhibits the HV output for approximately 0.25 seconds after each arc.

Arc Sensing: Internal circuitry senses the number of arcs caused by external load discharges. If the rate of consecutive arcs exceeds approximately one arc per second for 5 arcs, the supply will turn off for approximately 5 seconds to allow clearance of the fault. After this period the supply will automatically return to the programmed kV value with the rise time constant indicated. If the load fault still exists the above cycle will repeat.

RS232/USB/Ethernet Programming and Monitor Accuracy:

Resolution: 0.025% of full scale for both the voltage and the current programs. 0.1% of full scale for both the voltage and the current monitors.

Remote setting accuracy: Voltage setting accuracy is better than 0.5% of setting + 0.2% of rated.

Remote reading accuracy:

Voltage reading accuracy is 0.5% of reading + 0.2% of rated. Current reading accuracy is 1% of reading + 0.1% of rated.

Remote Control Unit: A separate control panel chassis is provided which contains all the control functions.

The front panel of this assembly contains: separate 10-turn controls with locking vernier dials used to set the voltage and current levels, High Voltage ON switch, High voltage OFF/Reset switch and an AC power on/off switch and indicator. LED's indicate when the high voltage is on, output polarity, interlock status, fault status, and whether the supply is operating in a voltage or current regulating mode. Output levels are indicated by voltage and current digital meters.

The rear panel of this assembly contains: AC Power On indicator, ground stud, driver/control chassis interface connectors, current limit/current trip selector switch, remote user interface connector and RS232/USB connectors.

The signals provided on the remote user interface connector are as follows:

Inputs: Output voltage and current program signals, and high voltage enable.

Outputs: Output voltage and current monitor signals, a +10V reference source, a high voltage status signal, fault status, and V/I mode status.

Signal common and ground reference terminals are also provided.

Remote HV Enable: 0 - 1.5V = OFF, 2.5 - 15V = ON.

External Interlock: Open = off, closed = on. Latching with reset via the HV ON switch. The front panel indicator is illuminated when the interlock is open. Interlock connections are provided on a terminal strip on the rear panel of the driver chassis.

Accessories: 25 feet of detachable interconnection cables, a 10 foot null modem cable, and a 10 foot USB cable are provided.

Options

Symbol Description

- ZR** Zero start Interlock. Voltage control, local or remote, must be zero before HV will enable.
- SS** Slow start ramp. Specify standard times of 5, 10, 15, 20, or 30 seconds + 20%.
- 5VC** 0-5 V voltage and current program/monitor.
- 200** 180-220 VRMS, 3Ø input, 48-63 Hz.
- 400** 340-460 VRMS, 3Ø input, 48-63 Hz. (Required for CE compliance.)
- ETH** Virtual RS-232 COM port over Ethernet network. (Requires compatible OS (eg Windows) for COM drivers)

Please consult factory for special requirements.

4 kW Models, Open Stack

Positive Polarity	Negative Polarity	Reversible Polarity	Output Voltage	Output Current	Max Stored Energy (J)	High Freq. Ripple (P-P)	Line Freq. Ripple (P-P)
LH200P20	LH200N20	LH200R20	0-200 kV	0-20 mA	109	150	20
LH250P16	LH250N16	LH250R16	0-250 kV	0-16 mA	129	160	20
LH300P12.5	LH300N12.5	LH300R12.5	0-300 kV	0-12.5 mA	159	150	20
LH350P9	LH350N9	LH350R9	0-350 kV	0-9 mA	180	130	20
LH400P7	LH400N7	LH400R7	0-400 kV	0-7 mA	211	110	20
LH450P6	LH450N6	LH450R6	0-450 kV	0-6 mA	243	105	20
LH500P5	LH500N5	LH500R5	0-500 kV	0-5 mA	264	100	20

8 kW Models, Open Stack

Positive Polarity	Negative Polarity	Reversible Polarity	Output Voltage	Output Current	Max Stored Energy (J)	High Freq. Ripple (P-P)	Line Freq. Ripple (P-P)
LH200P40	LH200N40	LH200R40	0-200 kV	0-40 mA	218	150	20
LH250P32	LH250N32	LH250R32	0-250 kV	0-32 mA	258	160	20
LH300P25	LH300N25	LH300R25	0-300 kV	0-25 mA	318	150	20
LH350P18	LH350N18	LH350R18	0-350 kV	0-18 mA	360	130	20
LH400P14	LH400N14	LH400R14	0-400 kV	0-14 mA	422	110	20
LH450P12	LH450N12	LH450R12	0-450 kV	0-12 mA	486	105	20
LH500P10	LH500N10	LH500R10	0-500 kV	0-10 mA	528	100	20

For Models Greater Than 8 kW, Please Consult Factory.

High Voltage Stack Assembly

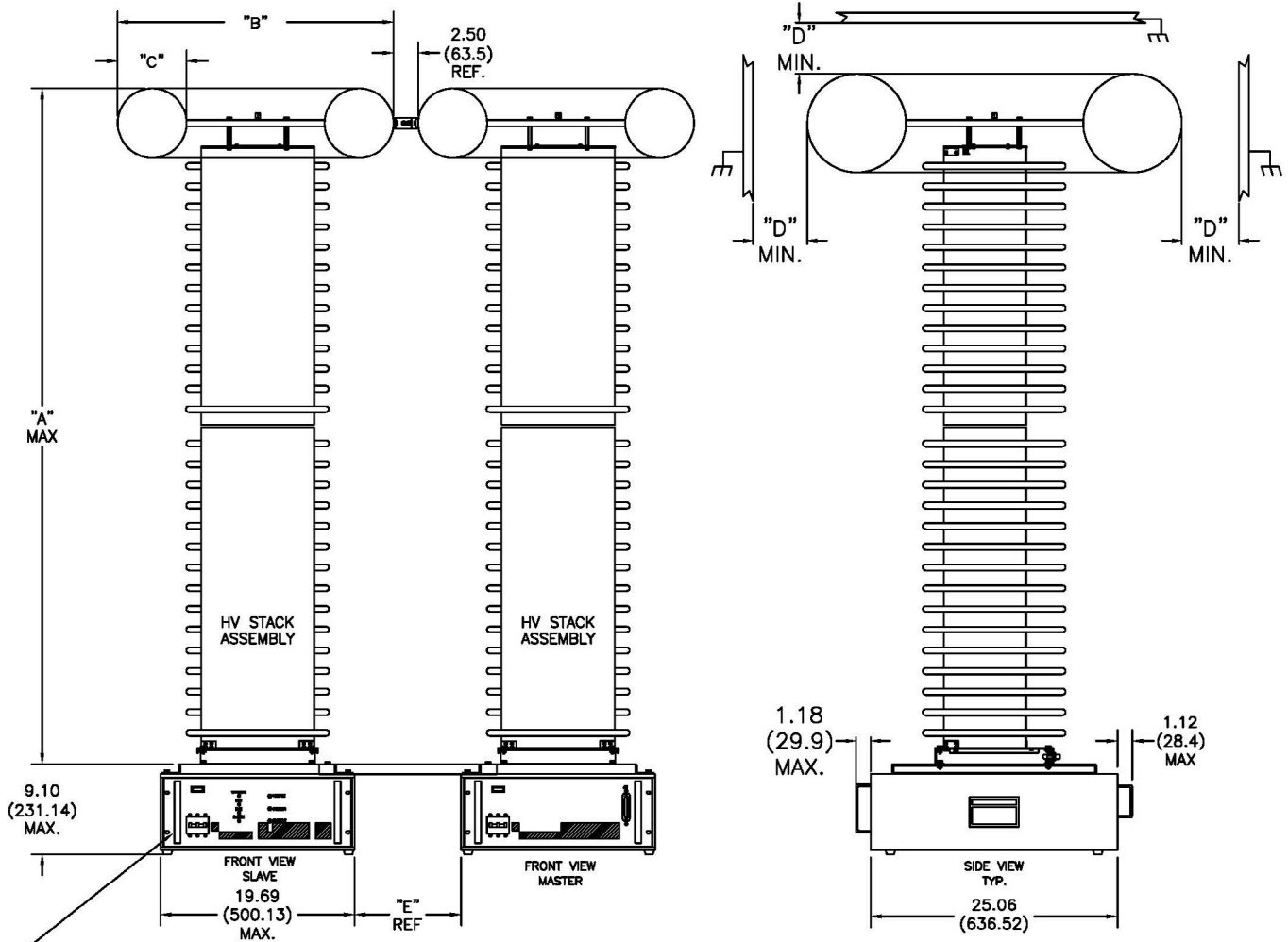

DRIVER ASSY & CABINET (REF)

STACK DIMENSIONS (NOMINAL)

RECOMMENDED MINIMUM CLEARANCE

SIZE KV	"A"	"B"	"C"	"D"	"E"
200KV	28.20 (716)	24.00 (610)	5.00 (127)	24 (610)	6.81 (172.97)
250KV	35.50 (902)	28.00 (711)	7.00 (178)	31 (787)	10.81 (274.57)
300KV	39.70 (1008)	28.00 (711)	7.00 (178)	38 (965)	10.81 (274.57)
350KV	52.00 (1321)	34.00 (864)	8.50 (216)	45 (1143)	16.81 (426.97)
400KV	56.20 (1427)	34.00 (864)	8.50 (216)	52 (1321)	16.81 (426.97)
450KV	61.10 (1552)	38.00 (965)	10.00 (254)	60 (1524)	20.81 (528.57)
500KV	69.50 (1765)	38.00 (965)	10.00 (254)	70 (1778)	20.81 (528.57)

Driver Assembly

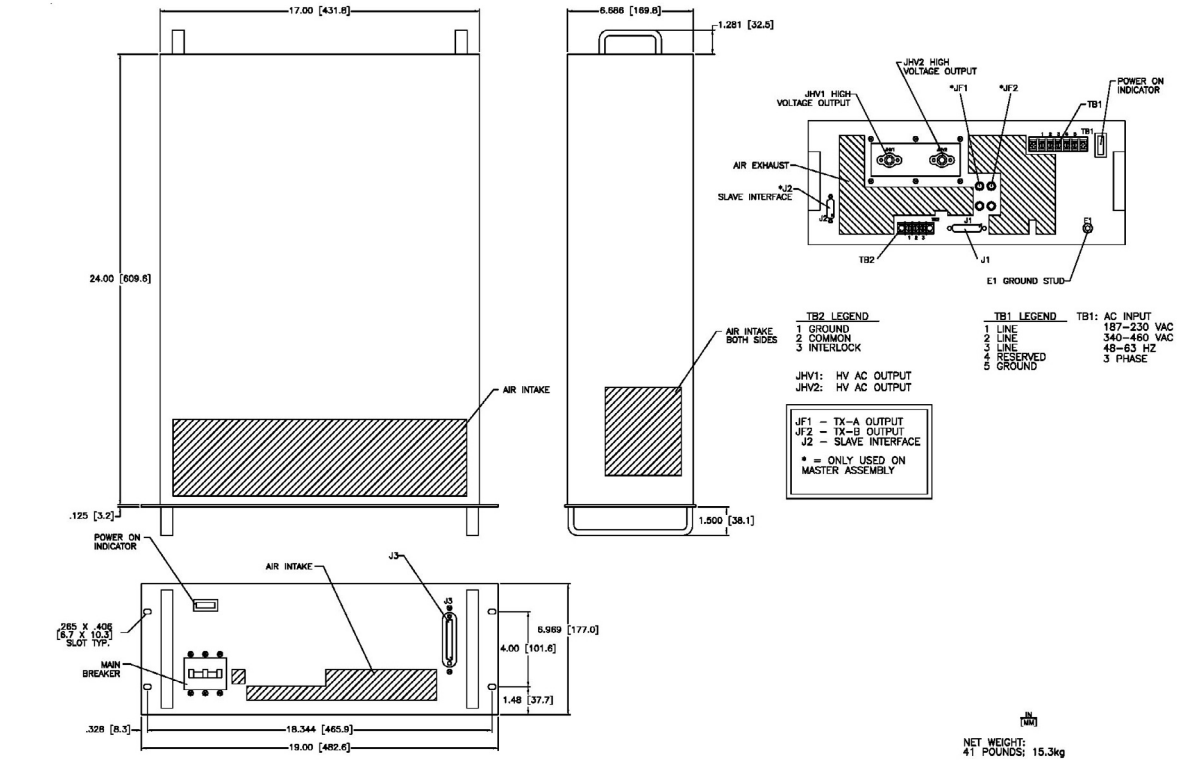

Driver Assembly - Slave

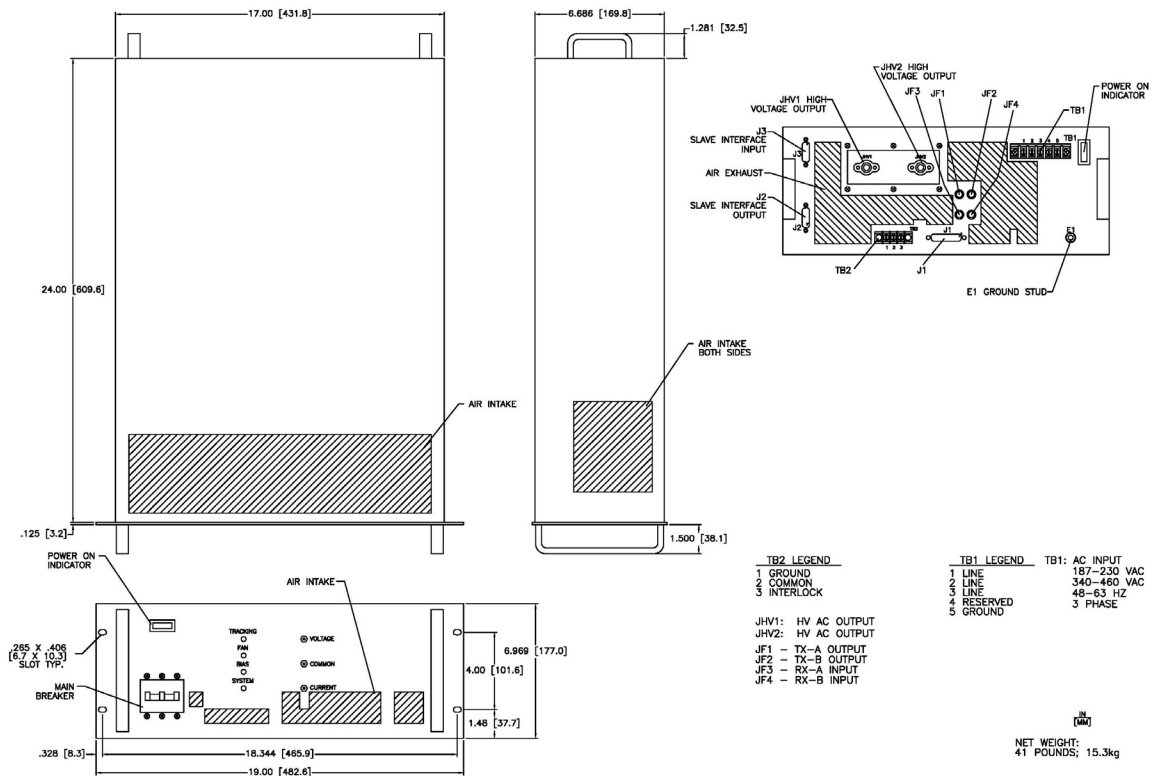

Remote Control Assembly

CONTROL ASSEMBLY

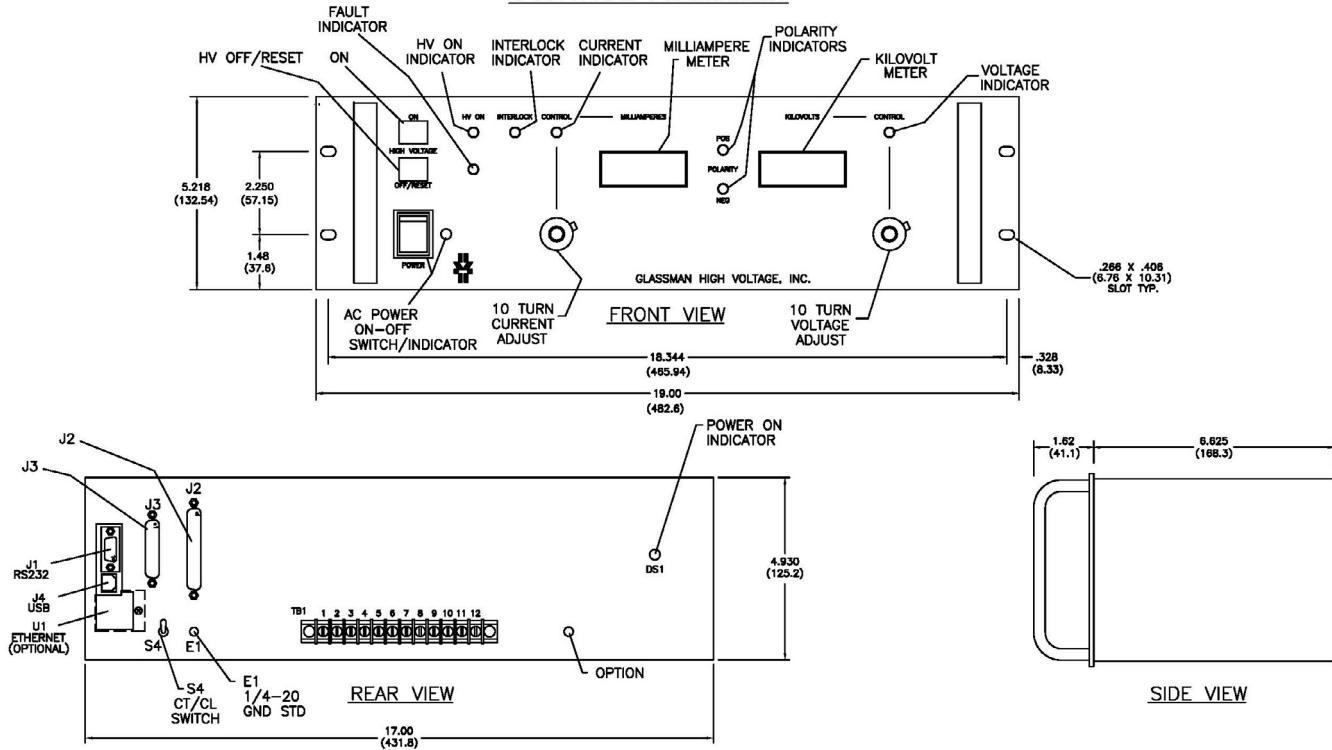

J3 LEGEND

1 HV ENABLE	16 THRU 24 RESERVED
2 HV STATUS	25 GROUND
3 FAULT STATUS	
4 MODE STATUS	
5 COMMON	
6 RESERVED	
7 GROUND	
8 V PROGRAM	
9 I PROGRAM	
10 SIG COMMON	
11 REFERENCE	
12 V MON	
13 I MON	
14 SIG COMMON	
15 COMMON	

TB1 LEGEND

1 GROUND
2 COMMON
3 RESERVED
4 DIG V PROGRAM
5 V PROGRAM
6 LOCAL V PROGRAM
7 DIG I PROGRAM
8 I PROGRAM
9 LOCAL I PROGRAM
10 DIG HV ENABLE
11 HV ENABLE
12 +10V REF

S4: CL/CT SELECT

8 kW System

