

Test Procedures for High Voltage Power Supplies

Test Procedures for High Voltage Power Supplies

Table of Contents

INTRODUCTION	2
I. LOADING METHODS FOR HIGH VOLTAGE POWER SUPPLIES	2
Constant (Fixed) Load	
Changing Load	
II. VOLTAGE CALIBRATION AND RANGE	3
Test Setup	
Test Method	
III. OUTPUT VOLTAGE STATIC REGULATION	4
Definition	
Test Setup	
Test Method, Static Line Regulation	
Test Method, Static Load Regulation	
IV. OUTPUT CURRENT REGULATION	5
Definition	
Test Setup	
V. RIPPLE	5
Definition	
Test Setup	
Test Method	
VI. TEMPERATURE COEFFICIENT	6
Definition	
Test Setup	
VII. STABILITY	6
Definition	
Test Setup	
Test Method	

Introduction

Every Glassman high voltage power supply is 100% inspected for conformance to specifications before it is shipped. It should be ready for immediate use upon arrival. Your company, however, may require an in-coming inspection before any equipment can be put in use. Many companies also schedule a periodic inspection to reduce the possibility of expensive downtime, extensive repairs, and manufacturing flaws caused by malfunctioning equipment.

Testing a high voltage power supply is not difficult. But it can be dangerous! The following "step-by-step" test procedure describes how to test each specification in a thorough and safe manner. These tests apply to all Glassman standard power supplies. Detailed factory test data sheets including rated values and acceptance levels are available for individual models on request.

CAUTION!

Standard models are shipped with a detachable high voltage output cable. This cable consists of a center conductor, a polyethylene insulating sleeve, a braided shield wire, and an outer insulating jacket. For connection to any test apparatus, the outer end of the cable should be stripped of both the insulating jacket and braided shield wire for a length equivalent to 1.25 inches per 10 kV of output voltage. The supplied output cable has been stripped adequately for the specific operating voltage of the unit. The entire output cable should then be suspended in air by a cord as it goes from the power supply to the test apparatus to avoid any contact with grounded circuits.

I. Loading Methods for High Voltage Power Supplies

Constant (Fixed) Load

Connect the load resistor, R, and a current monitor, I, as shown in Figure 1a to apply a constant load to the power supply. One end of the resistor is connected to the high voltage unshielded tip of the output cable by an appropriate lead. The other end is connected to the current monitor. The load resistor must have voltage and wattage ratings sufficient to withstand the highest voltage to be applied and to avoid excessive heating, which could cause the load resistor to drift in value. In practice, this means that the load resistor must be constructed from a series of smaller resistors connected in series to limit the voltage drop across any one resistor to a safe level. Care must be taken to space these resistors far enough apart to avoid arcing. Notice that the current monitor is connected in series with the low voltage return path, keeping it at a low and safe potential.

Changing Load

To apply a load that changes in value, refer to Figure 1b. Load resistor R1 is selected to load the supply with the minimum desired load. If it is desired to establish a no-load condition, R1 should be infinite, or an open circuit. One end of R1 is connected to the output cable tip by an appropriate lead. The other end of R1 is connected to the current monitor, which again is in the low voltage return path. Load resistor R2 is selected to achieve the desired maximum load. The equivalent maximum load, R3, is equal to $R1 \times R2 / R1 + R2$. Both R1 and R2 must be capable of withstanding the maximum voltage and wattage to be applied. Because the resistance of R2 is generally smaller than that of R1, it will dissipate the greatest power. Again, in practice, the load resistors must be constructed from a series of smaller resistors.

One end of R2 is connected to the junction of R1 and the current monitor. The other end of R2 is attached to one end of an insulated rod. This rod should be Plexiglas or other acrylic material. A 2-foot rod is adequate for voltages below 100 kV. This rod, held at the opposite end from R2, is used temporarily to make contact with the output cable tip and increase the load to the supply. Both ends are at a low and safe potential when the rod is withdrawn from the cable tip.

Figure 1a

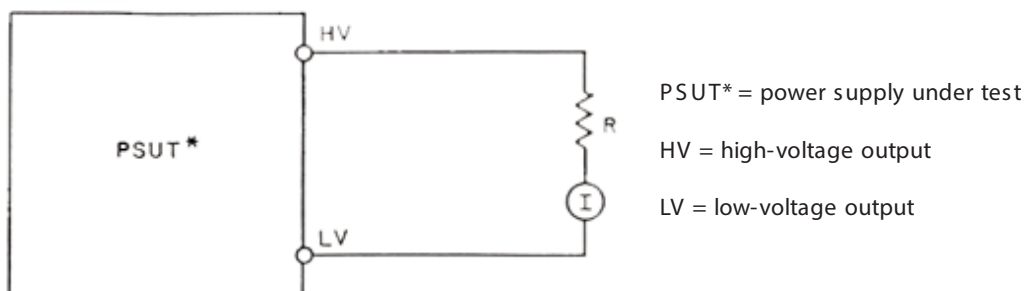
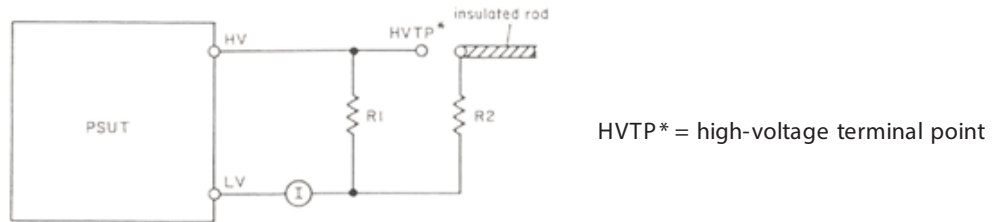

Figure 1b



II Voltage Calibration and Range

Test Setup

To measure the output voltage of a power supply, refer to the test setup shown in Figure 2. A resistive divider is used to attenuate the high voltage by a known amount to a level where it can be measured conveniently by a standard DC voltmeter. RT represents the end-to-end resistance of the divider. It is also the load presented to the supply. If measurements are to be made at no-load conditions, RT should be at least 10 times the normal load resistance value. R1 represents the resistor across which the measured voltage is developed. It is in the low voltage return path for safety purposes. The ratio of R1 to RT is the amount of attenuation. If that ratio is made 1/1000, a voltmeter will read directly in kV.

Designing a high voltage attenuator is a straightforward task. However, it may not be an easy task because of the high voltages involved. RT must be constructed from a large number of smaller resistors. These resistors are connected in series with one another to reduce the voltage drop across each individual resistor to a level it can safely handle, both from a voltage coefficient and dissipation point of view. Resistors must be spaced far enough apart, if air forms the insulation medium, or encapsulated, or immersed in dielectric oil, to avoid arcing. R1 must be small in value so that the input resistance of the voltmeter does not load it. All resistors must have low, or matched, temperature and voltage coefficients to avoid changes in attenuation with temperature or attenuation that drifts with changing voltage levels.

Test Method

Once a suitable attenuator is available, measurements of output voltage are simple and straightforward. If the supply has a metered output, or a remote monitoring terminals, those indications can be compared to the measured results. For measurements of output voltage at other than no-load, refer to Figure 3. The added load resistor is constructed and connected exactly as described above under "Changing Load."

Figure 2

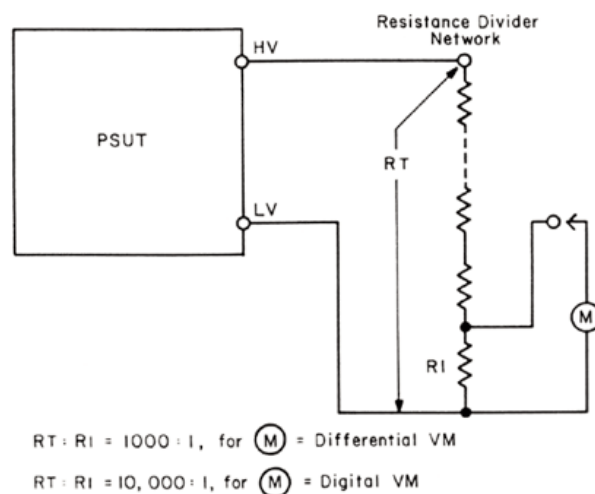

III Output Voltage Static Regulation

Definition

Most power supply manufacturers define static regulation as the change in output voltage resulting directly from a change in input supply voltage (Line-regulation) or from a change in load resistance (load-regulation). Changes in output voltage resulting from changes in temperature or time are specifically excluded from this definition. As a result, static regulation is measured at "constant temperature" and over "short" time intervals (i.e., several seconds, allowing the output to stabilize after the load has been charged).

Test Setup

Connect the output voltage measuring circuit as shown in Figure 3.

Test Method, Static Line Regulation

Select the test setup for constant (fixed) load. Adjust the supply input voltage over the specified range by means of the autotransformer and record the changes in DC output voltage. Regulation is specified as the change expressed as a % of the output voltage.

Test Method, Static Load Regulation

Connect the output voltage measuring circuit as shown in Figure 3. Adjust the input voltage to nominal. Vary the load and record the change in output voltage. Static load regulation may be specified at other than nominal input voltage and at various output voltage levels, if desired.

Note: (1) All the above applies only to static regulation. Dynamic regulation may be important if the line or load may be expected to change abruptly or when the load is sensitive to transient deviations of the output voltage. If it is necessary to measure dynamic regulation, please consult the Glassman Engineering Department. (2) The voltage measuring meter, M, must have sufficient resolution to indicate the small regulation change levels.

Figure 3

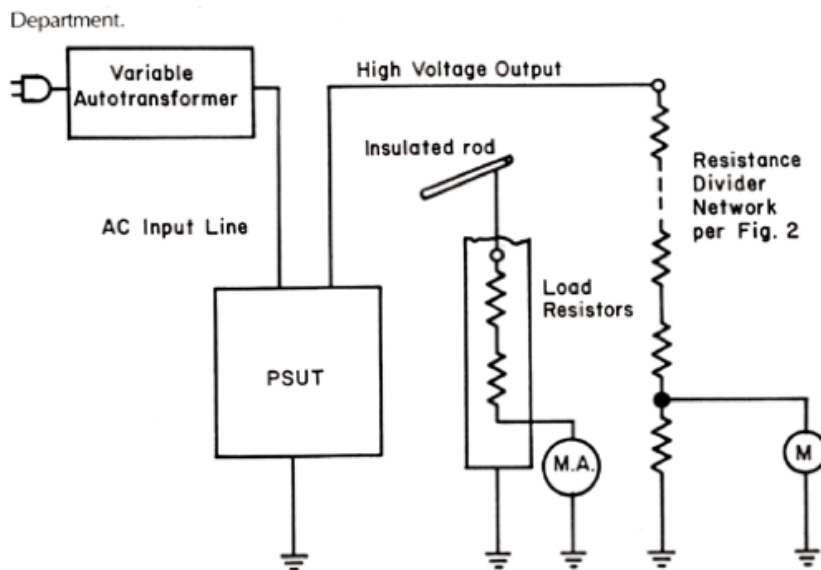

Variable Autotransformer - 105-125V AC, 50/60 Hz, Wattage as required to supply PSUT.
Load resistors - immersed in oil or other insulating medium, if required.

IV Output Current Regulation

Definition

Output current regulation is defined as the change in output current that is caused by a change in input supply voltage, load resistance, or both. Line current regulation is specified as the percentage change in current that occurs when the supply input is varied over its specified range. Load current regulation is specified as the change in current that occurs when the load is varied from short-circuit to rated voltage. This parameter is important for high voltage supplies that are capable of operation in a "current regulated" or "constant current" mode.

Test Setup.

To measure current regulation, refer to Figure 4. R_L represents the load resistor. Its value will vary from 0, at the short-circuit condition, to some finite value at the rated-voltage condition. Because a power supply cannot maintain current regulation into an open circuit, load changes are introduced by shorting portions of the load resistor. A current-sensing resistor, R_S , in series with the low voltage return path, is used to develop a voltage that is proportional to the current, and which can be measured by a suitable DC voltmeter.

Figure 4

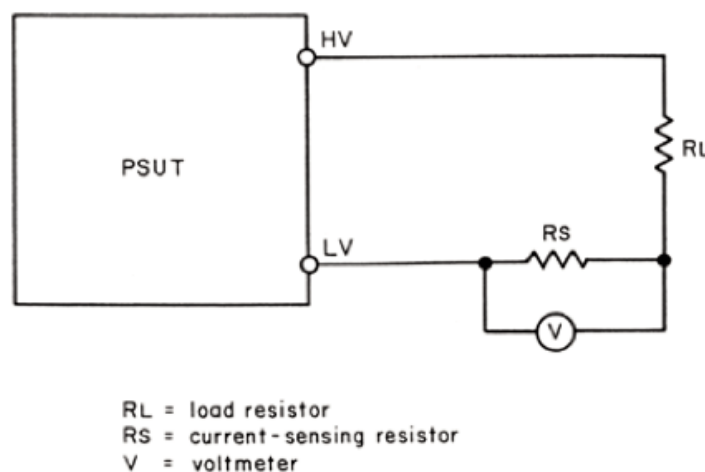

V Ripple

Definition

Ripple is defined as the amount of AC voltage that is superimposed on the DC output voltage. It is usually specified as the maximum AC voltage expressed as % RMS of the rated DC output voltage at full load. This is a worst-case condition because, for capacitor input filter networks, ripple is directly proportional to load current, decreasing in value with decreasing current. Glassman power supplies have two components of ripple voltage; a low frequency (mains related) voltage derived from the AC line and a high frequency related (30-130kHz) voltage generated by the switching circuits in the supply.

Test Setup.

To measure ripple, refer to Figure 5. C represents the blocking capacitor required to prevent DC voltage from entering the AC measuring circuit. A resistor, R , and a spark-gap, SG , protect the measuring circuit from possible current surges. R and C must be chosen to pass the lowest frequencies of interest without attenuation. Note that the total value of R includes the DC probe resistance of the oscilloscope. Because of the high DC voltages involved, it is not possible to, use a single capacitor. Instead, C is constructed from C 's, all connected in series. In this way, the DC voltage on any one capacitor is reduced by a factor equal to the number of capacitors used. The maximum voltage across R is limited to the spark gap, SG , voltage. As mentioned earlier, Glassman offers a series of three DC voltage dividers that also include a ripple measuring circuit.

With a suitable ripple measuring circuit in place, set output voltage, load current, and input voltage to specified values. Read the peak-to-peak ripple on an oscilloscope. To convert p-p values to approximate RMS values, divide by 2.828.

Figure 5

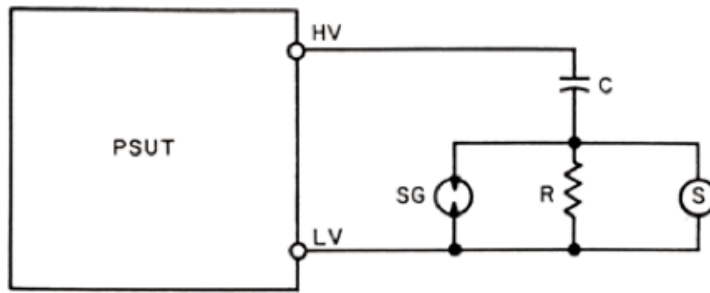

C = DC blocking capacitor
SG = spark gap
S = oscilloscope

VI Temperature Coefficient

Definition

Temperature coefficient is defined as the percentage change in output voltage per degree C, with all other operating conditions held constant.

Test Setup.

The power supply must be put in an environmental chamber whose temperature can be precisely controlled over the specified temperature range. Using the test setup of Section II, set all operating conditions to specified values. Starting at the lowest temperature, hold the temperature constant until a stable output voltage is obtained. Continue this procedure until the highest temperature is reached. The slope of the curve of voltage versus temperature is the temperature coefficient, expressed in volts per degree C. To change to % / degree C, divide by the nominal output voltage and multiply by 100.

VII Stability

Definition

Stability is defined as the percent change in output voltage per unit of time, with all other operating conditions constant.

Test Setup

The test setup for stability is the same as for temperature coefficient. A range of temperatures are also used. The difference in the two tests is that for stability measurements the test conditions are held for a specific time at a constant temperature rather than for just a stable output to occur. Standard time periods are per 10 minutes, 1 hour, or 8 hours.

Test Method

Set input voltage, output voltage, load, and temperature to desired levels. Monitor output voltage continuously, preferably on a strip chart recorder.