

# MULTICOM 384

## I/O EXPANSION CARD

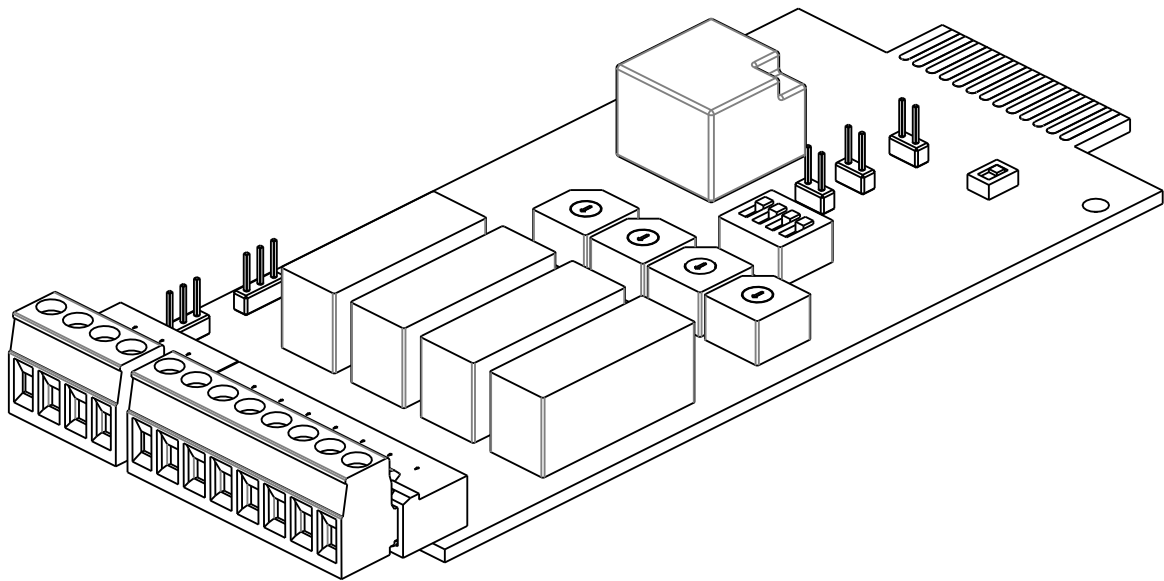

USER MANUAL



---

## INTRODUCTION

Thank you for choosing our product.

The accessories described in this manual are of the highest quality, carefully designed and built in order to ensure excellent performance.

This manual contains detailed instructions on how to install and use the product.

**This manual must be stored in a safe place and CONSULTED BEFORE USING THE DEVICE for proper usage instructions as well as maximum performance from the device itself.**

**NOTE:** Some images contained in this document are for informational purposes only and may not faithfully demonstrate the parts of the product they represent.

Symbols used in this manual:



**Danger**

Indicates the possible presence of dangerous voltages and the risk of electric shock.



**Warning**

Indicates important information that must not be ignored.



**Information**

Provides notes and useful suggestions for the User.

---

## SAFETY

**This part of the manual contains SAFETY precautions that must be followed scrupulously.**

Ensure that the connectors subjected to high voltages are correctly isolated.

- ❖ The device has been designed for professional use and is therefore not suitable for use in the home.
- ❖ The device has been designed to operate only in closed environments. It should be installed in rooms where there are no inflammable liquids, gas or other harmful substances.
- ❖ Take care that no water or liquids and/or foreign bodies fall into the device.
- ❖ In the event of a fault and/or impaired operation of the device, do not attempt to repair it but contact the authorized service centre.
- ❖ The device must be used exclusively for the purpose for which it was designed. Any other use is to be considered improper and as such dangerous. The manufacturer declines all responsibility for damage caused by improper, wrong and unreasonable use.

---

## ***ENVIRONMENTAL PROTECTION***

Our company devotes abundant resources to analysing environmental aspects in the development of its products. All our products pursue the objectives defined in the environmental management system developed by the company in compliance with applicable standards.

Hazardous materials such as CFCs, HCFCs or asbestos have not been used in this product.

When evaluating packaging, the choice of material has been made favouring recyclable materials.

Please separate the different material of which the packaging is made and dispose of all material in compliance with applicable standards in the country in which the product is used.

---

## ***DISPOSING OF THE PRODUCT***

The device contains internal material which (in case of dismantling/disposal) are considered TOXIC, such as electronic circuit boards. Treat these materials according to the laws in force, contacting qualified centres. Proper disposal contributes to respect for the environment and human health.

---

# CONTENTS

<b>DESCRIPTION</b>	<b>7</b>
<i>KIT CONTENTS</i>	7
<i>DESCRIPTION AND CHARACTERISTICS</i>	7
<i>OPERATION</i>	8
<i>INPUT</i>	8
<i>OUTPUT</i>	9
<i>ROTARY SWITCHES SW #</i>	10
<i>DELAY TIME</i>	10
<b>CARD INTALLATION INTO UPS</b>	<b>11</b>
<i>PROTECTION IN CASE OF DANGEROUS VOLTAGE SIGNALS</i>	11
<b>CARD CONFIGURATION</b>	<b>12</b>
<b>SERIES VST / VSD</b>	<b>13</b>
<i>INPUT #1</i>	14
<i>INPUT #2</i>	14
<i>INPUT #3</i>	16
<i>CONFIGURATION VIA SOFTWARE OF OUTPUT</i>	17
<b>SERIES SEP / SDH / SDU (4kVA)</b>	<b>18</b>
<i>INPUT #1</i>	18
<i>INPUT #2</i>	19
<i>INPUT #3</i>	20
<i>CONFIGURATION VIA SOFTWARE OF OUTPUT</i>	21
<b>SERIES SDL (3,3÷4kVA)</b>	<b>22</b>
<i>INPUT #1</i>	22
<i>INPUT #2</i>	23
<i>INPUT #3</i>	24
<i>CONFIGURATION VIA SOFTWARE OF OUTPUT</i>	25
<b>SERIES SDL (5÷6kVA) / SPT / SPW</b>	<b>26</b>
<i>INPUT #1</i>	26
<i>INPUT #2</i>	27
<i>INPUT #3</i>	28
<i>CONFIGURATION VIA SOFTWARE OF OUTPUT</i>	29
<b>SERIES SDU (5÷10kVA)</b>	<b>30</b>
<i>INPUT #1</i>	30
<i>INPUT #2</i>	31
<i>INPUT #3</i>	32
<i>CONFIGURATION VIA SOFTWARE OF OUTPUT</i>	33
<b>SERIES SPH</b>	<b>34</b>
<i>INPUT #1</i>	35
<i>INPUT #2</i>	35
<i>INPUT #3</i>	36
<i>CONFIGURATION VIA SOFTWARE OF OUTPUT</i>	37
<b>SERIES MST / MSM / MCT / MCM / C1T / C1M / GMI</b>	<b>38</b>
<i>INPUT #1</i>	38
<i>INPUT #2</i>	39
<i>INPUT #3</i>	39
<i>CONFIGURATION VIA SOFTWARE OF OUTPUT</i>	40
<b>SERIES MPW</b>	<b>41</b>
<i>CONFIGURATION VIA SOFTWARE OF INPUT</i>	41
<i>CONFIGURATION VIA SOFTWARE OF OUTPUT</i>	41



# DESCRIPTION

## KIT CONTENTS

- MultiCOM 384 card
- Metal slot cover
- Protection cover
- Protection shells
- Cable gland
- Screws

## DESCRIPTION AND CHARACTERISTICS

The MultiCOM 384 card allows to remote the commands to turn off and / or turn on the UPS and some UPS status.

The card should be inserted in the UPS slot.

This card is compatible with most UPS products in our portfolio, but some features may not be available on some UPS.

Please read carefully this guide to properly configure the board and the UPS.

The MultiCOM 384 card has two removable terminal blocks.

On the first (4 poles) there are the control signals to the UPS (eg the command to turn off the UPS), while on the second (8 poles) there are the outputs of 4 exchange relays for the signals coming from the ' UPS (eg contact for signaling battery operation).

### ALLOCATION OF CONFIGURATION SWITCHES AND THE TERMINAL BOARDS

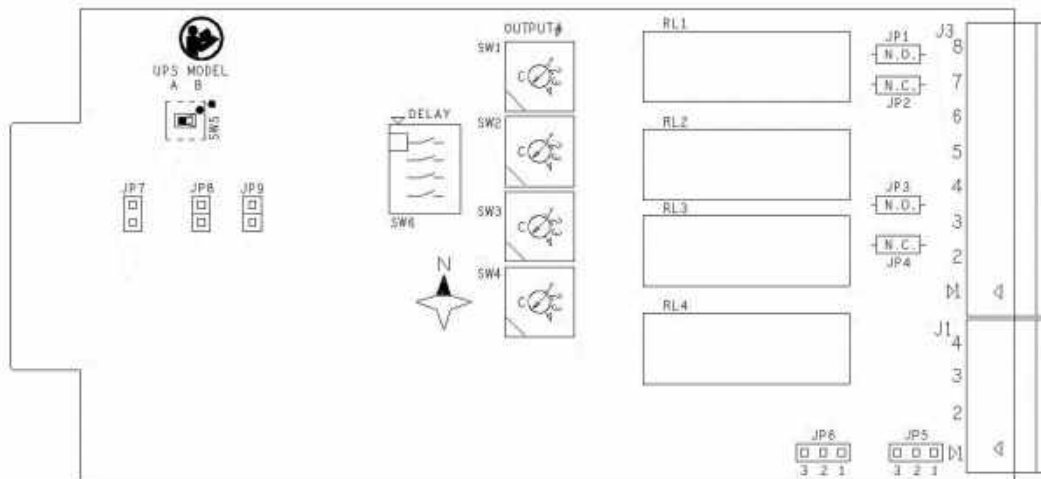

---

## OPERATION

### INPUT

MultiCOM 384 has 3 inputs to control the UPS:

- INPUT #1
- INPUT #2
- INPUT #3

#### INPUT #1

INPUT #1 is generally dedicated to remote on.



**NOTE:** in some UPS the function assigned to INPUT #1 is configurable.

#### INPUT #2

INPUT #2 is generally dedicated to remote off.



**NOTE:** in some UPS the function assigned to INPUT #2 is configurable.

#### INPUT #3

INPUT #3 is generally dedicated to bypass command (*Service bypass* or *Load on bypass*).



**NOTE:**

- In some UPS the function assigned to INPUT #3 is configurable.
- Configuring properly the card, you can get a + 12Vdc isolated auxiliary power as an alternative to the INPUT #3.



**NOTE:** some UPS may not handle all inputs; check the features that are compatible with your UPS model in the chapter "CONFIGURATION CARD"



## OUTPUT

MultiCOM 384 card has 4 dry contacts associated to the UPS status and/or alarms:

- OUTPUT #1
- OUTPUT #2
- OUTPUT #3
- OUTPUT #4

By default, OUTPUTs are already associated with events; however, in many UPS series, these associations can be edited through configuration software.

OUTPUT	1	2		3	4	
EVENT	BATTERY LOW	BATTERY WORKING		INVERTER LOCKED	LOAD ON BYPASS	
RELAY	RL1	RL2		RL3	RL4	
CONTACT	N.O.	N.O.	N.C.	N.C.	N.O.	N.C.
PIN #	7	6	5	3	2	1



**NOTE:** check the features that are compatible with your UPS model in the "CONFIGURATION CARD" chapter.

The figure below shows the internal connections between the Relay contacts (two relays with switched contacts, a normally closed contact (N.C.) relay and a normally open contact (N.O.) relay and terminal block J3.

CONTACTS ON THE INTERNAL RELAYS AND CONNECTION TO THE TERMINALS

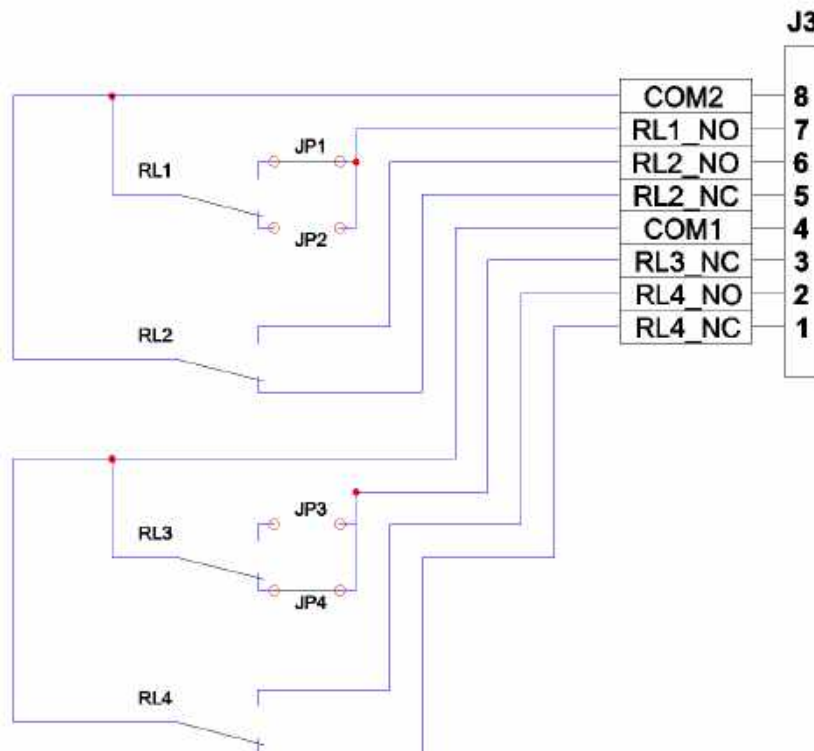

**NOTE:** to provide more flexibility to the installations, relays have been divided into two groups. In this way, the two relay groups can work with two different working voltages, or work on two separate systems.



**ATTENTION:** you can apply a maximum voltage of 250 V and a maximum current of 3 A for each pin.

## ROTARY SWITCHES SW #

The rotary switches SW1-SW2-SW3-SW4 can be used to modify the association between UPS outputs and relays.



**NOTE:** it is possible to associate the same signal to two or more relays.

RELAY	ROTARY SW	UPS OUTPUT
RELAY 1	SW1	<b>POS. 1</b> <b>OUTPUT #1</b>
		POS. 2      OUTPUT #2
		POS. 3      OUTPUT #3
		POS. 4      OUTPUT #4
RELAY 2	SW2	POS. 1      OUTPUT #1
		<b>POS. 2</b> <b>OUTPUT #2</b>
		POS. 3      OUTPUT #3
		POS. 4      OUTPUT #4
RELAY 3	SW3	POS. 1      OUTPUT #1
		POS. 2      OUTPUT #2
		<b>POS. 3</b> <b>OUTPUT #3</b>
		POS. 4      OUTPUT #4
RELAY 4	SW4	POS. 1      OUTPUT #1
		POS. 2      OUTPUT #2
		POS. 3      OUTPUT #3
		<b>POS. 4</b> <b>OUTPUT #4</b>



**ATTENTION:** before change the position of the switches on SW # rotary switches, check the features that are compatible with your UPS model in the "CONFIGURATION CARD" chapter.

## DELAY TIME

By switching on the dip switch SW6, it is possible to delay the switching (8-10 seconds) in respect to the activation of the control signal. This delay can be useful for filtering short unwanted conditions such as instantaneous network interruptions, bypass operations for distorted loads, and so on.

Each switch is associated with a relay, and by default all switches are in OFF position.

### DIP SWITCH SW6: EXAMPLE ACTIVATION DELAY FOR RELAY RL2

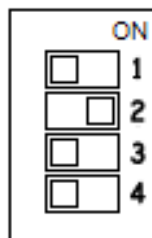

**NOTE:** the delay activation has effect on the closing and on the opening of the relay together.

## CARD INTALLATION INTO UPS



**ATTENTION:** make sure you have correctly configured the MultiCOM 384 card before install it in the UPS. Incorrect configuration may cause card malfunction, immediate shutdown of the UPS, and consequent loss of load. To properly configure the card, refer to the chapter "CONFIGURATION CARD" in this manual.

- Remove the cover of the device expansion slot by removing the two retaining screws
- Insert MultiCOM 384 in the slot.
- Close the slot with the cover supplied in the kit and fasten it in place using the two screws that were removed previously.



**ATTENTION:** failure to fix the card could cause its malfunction.

- At the end of the installation, it is recommended to cover the two terminal blocks with the shells supplied in the KIT. This will avoid accidental contacts with the terminals when using signal circuits with dangerous voltages.

---

## PROTECTION IN CASE OF DANGEROUS VOLTAGE SIGNALS

An additional protection cover and two protection shells are provided with the kit. Insert the card into the slot, lock it with the metal cover and then, if the 4 fixing holes are present on the UPS, assemble the protection cover. Otherwise, if the fixing holes are not present, assemble the two protection shells.

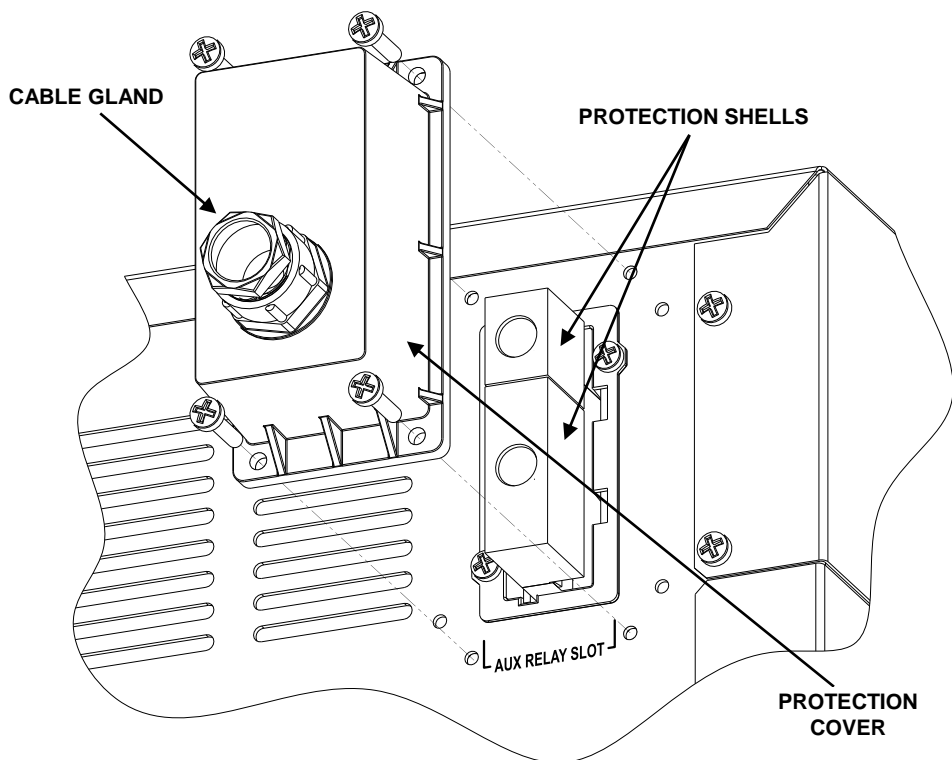

# CARD CONFIGURATION

The MultiCOM 384 card is compatible with most UPS series. This chapter will show board settings and features for each UPS series.

Refer to the code on the UPS data plate to trace back to the UPS model you own (ex. P/N: CSDUK10AA5...).

SWITCH / JUMPER / TERMINALS	DEFAULT CONFIGURATION
<b>SW5</b> (UPS MODEL)	<b>A</b>
<b>JP7</b> (PIN STRIP)	<b>OPEN</b>
<b>JP8</b> (PIN STRIP)	<b>OPEN</b>
<b>JP9</b> (PIN STRIP)	<b>OPEN</b>
<b>JP5</b> (PIN STRIP)	<b>2-3</b>
<b>JP6</b> (PIN STRIP)	<b>2-3</b>
<b>J1</b> (4 WAYS TERMINAL)	<b>3-4</b>

## DEFAULT CONFIGURATION

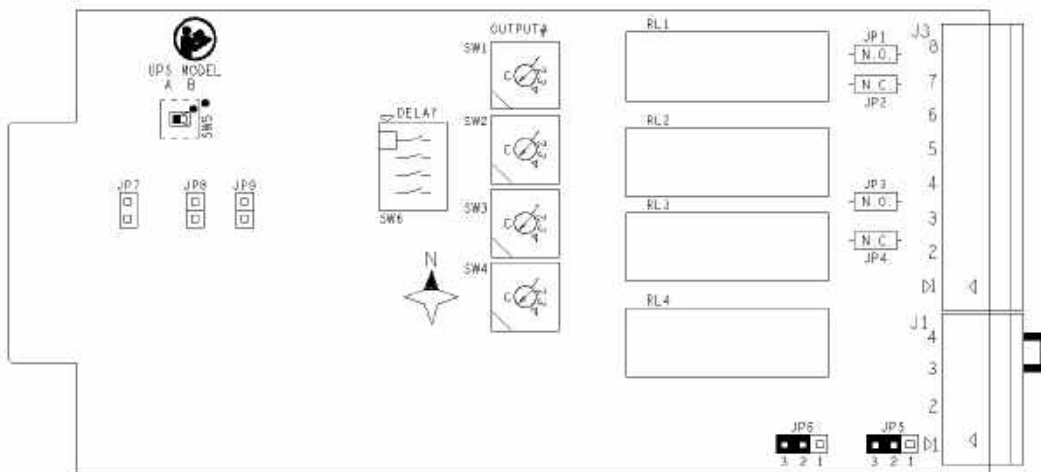

## SERIES VST / VSD

Below are the instructions for configuring the MultiCOM 384 card, the possible settings and features of the card for the series VST / VSD.

SWITCH / JUMPER / TERMINALS	BASIC CONFIGURATION	OPTIONS
<b>SW5</b> (UPS MODEL)	<b>A</b>	<b>FIXED</b>
<b>JP7</b> (PIN STRIP)	<b>CLOSED</b>	<b>FIXED</b>
<b>JP8</b> (PIN STRIP)	<b>OPEN</b>	<b>FIXED</b>
<b>JP9</b> (PIN STRIP)	<b>OPEN</b>	<b>FIXED</b>
<b>JP5</b> (PIN STRIP)	<b>2-3</b>	<b>FIXED</b>
<b>JP6</b> (PIN STRIP)	<b>1-2</b>	<b>CONFIGURABLE</b>
<b>J1</b> (4 WAYS TERMINAL)	<b>3-4</b>	<b>CONFIGURABLE</b>

### BASIC CONFIGURATION

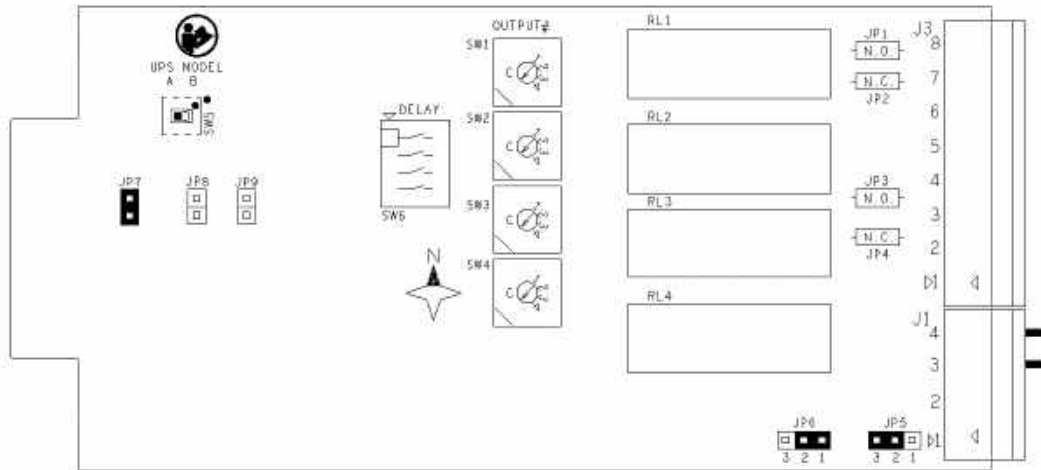

## INPUT #1

### CONFIGURABLE INPUT

You can assign different functions to the INPUT #1 via the UPS configuration software.  
The default configuration for INPUT #1 is NO FUNCTION (input disabled).

Possible configurations are:

- **No function**
- Remote on
- Remote off
- Remote on/off

Using a normally open push button / switch connected between pin 2 and 4 of J1 (4-way terminal block), you can activate the function associated with INPUT #1 when the contact is closed.

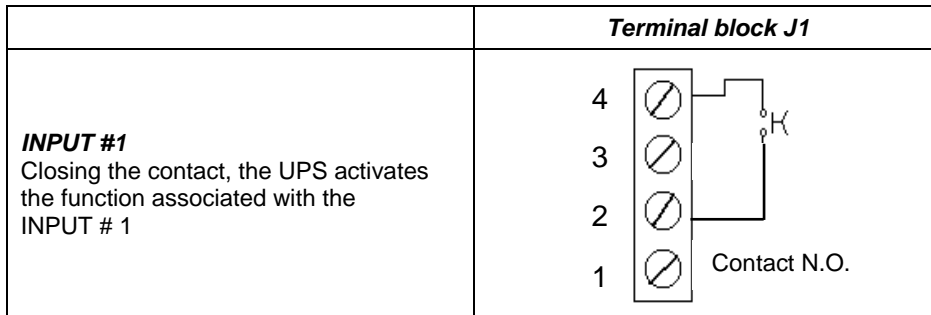

#### **ATTENTION:**

- INPUT #1 does not work if the UPS is powered off and completely switched off.
- After installation, it is advisable to check that the UPS is switched on by the INPUT # 1 input.
- With REMOTE ON, you can open the pin count between pins 2 and 4 when the UPS is started.

## INPUT #2

### CONFIGURABLE INPUT (1)

You can assign different functions to the INPUT #2 via the UPS configuration software.  
The default configuration for INPUT #2 is NO FUNCTION (input disabled).

Possible configurations are:

- **No function**
- Remote on
- Remote off
- Remote on/off

### INPUT FOR REMOTE SHUTDOWN (2)

You can manage INPUT #2 input either with a N.C contact than with a N.O. contact.

#### **NOTE:**

(1) For VST series.

(2) For VSD series.

**INPUT #2 with N.C. contact**

Card configuration:

- Insert the jumper between pins 1 and 2 of **JP6** (3-pin strip pins on the card)

Using a normally closed push button / switch, connected between pin 3 and pin 4 of J1 (4-way terminal block), you can turn on or off the UPS (depending on the set configuration) when the contact is opened.

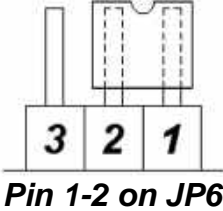
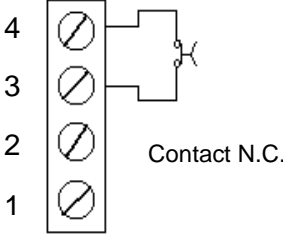
	<i>Position of the jumper on JP6</i>	<i>Terminal block J1</i>
<p><b>INPUT #2 with N.C. contact</b> Opening the contact, UPS activates the function associated with the INPUT #2</p>	 <p><b>Pin 1-2 on JP6</b></p>	 <p>4 3 2 1</p> <p>Contact N.C.</p>

**INPUT #2 with N.O. contact**

Card configuration:

- Insert the jumper between pins 2 and 3 of **JP6** (3-pin strip pins on the card)

Using a normally open push button / switch, connected between pin 3 and pin 4 of J1 (4-way terminal block), you can turn on or off the UPS (depending on the set configuration) when the contact is closed.

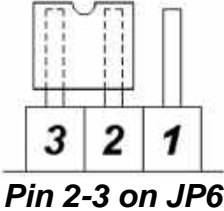
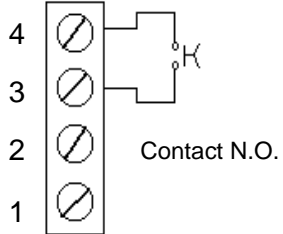
	<i>Position of the jumper on JP6</i>	<i>Terminal block J1</i>
<p><b>INPUT #2 with N.O. contact</b> Closing the contact, UPS activates the function associated with the INPUT #2</p>	 <p><b>Pin 2-3 on JP6</b></p>	 <p>4 3 2 1</p> <p>Contact N.O.</p>



**ATTENTION:**

- Setting INPUT #2 with N.C. contact, removing the jumper or 4-pole connector, if the UPS is turned on, it will switch off.
- If you insert the MultiCOM 384 card into the SLOT without the jumper on the J1 connector on the card, the UPS will switch off instantly.
- The shutdown command is an immediate REMOTE OFF command and does not remain in memory in the UPS, so you can restart the UPS again without restoring the original status of the contact.
- INPUT #2 does not replace R.E.P.O. contact of the UPS, but is an additional one, so for the UPS to work properly, do not remove the R.E.P.O. contact located on the back of the UPS. <sup>(3)</sup>

**NOTE:**

<sup>(3)</sup> For VSD series.

### INPUT #3

The MultiCOM 384 board does not handle the INPUT #3 in the VST / VSD series.

### Isolated auxiliary power supply + 12Vdc

Card configuration:

- Insert jumper between pin 2 and 3 of **JP5** (3-pin strip pins on the card)

Modifying the jumper position on the JP5 pin strip, you can get a + 12Vdc isolated auxiliary power instead of INPUT #3, useful for powering small devices such as optocouplers needed to send clean contacts to the UPS.

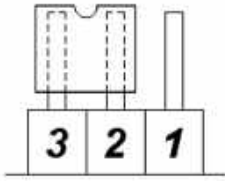
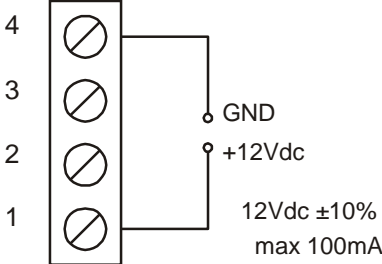
	<i>Position of the jumper on JP5</i>	<i>Terminal block J1</i>
<i>Isolated aux. power +12Vdc 100mA max</i>	 <p><b>Pin 2-3 of JP5</b></p>	 <p>4 3 2 1</p> <p>GND +12Vdc</p> <p>12Vdc ±10% max 100mA</p>



#### **ATTENTION:**

- Pins 1 and 4 deliver a maximum of 100mA.
- The supplied voltage is 12Vdc ± 10%.
- An absorption greater than the indicated value, or a short circuit, causes an immediate UPS shutdown due the failure of power supply for INPUT # 1 and INPUT # 2 inputs (configurable as REMOTE OFF).



## CONFIGURATION VIA SOFTWARE OF OUTPUT

Outputs that are configurable via software are as follows:

- OUTPUT #1
- OUTPUT #3

The outputs OUTPUT #2 and OUTPUT #4 cannot be configured via software.



**NOTE:** you can associate the same signal to multiple relays.

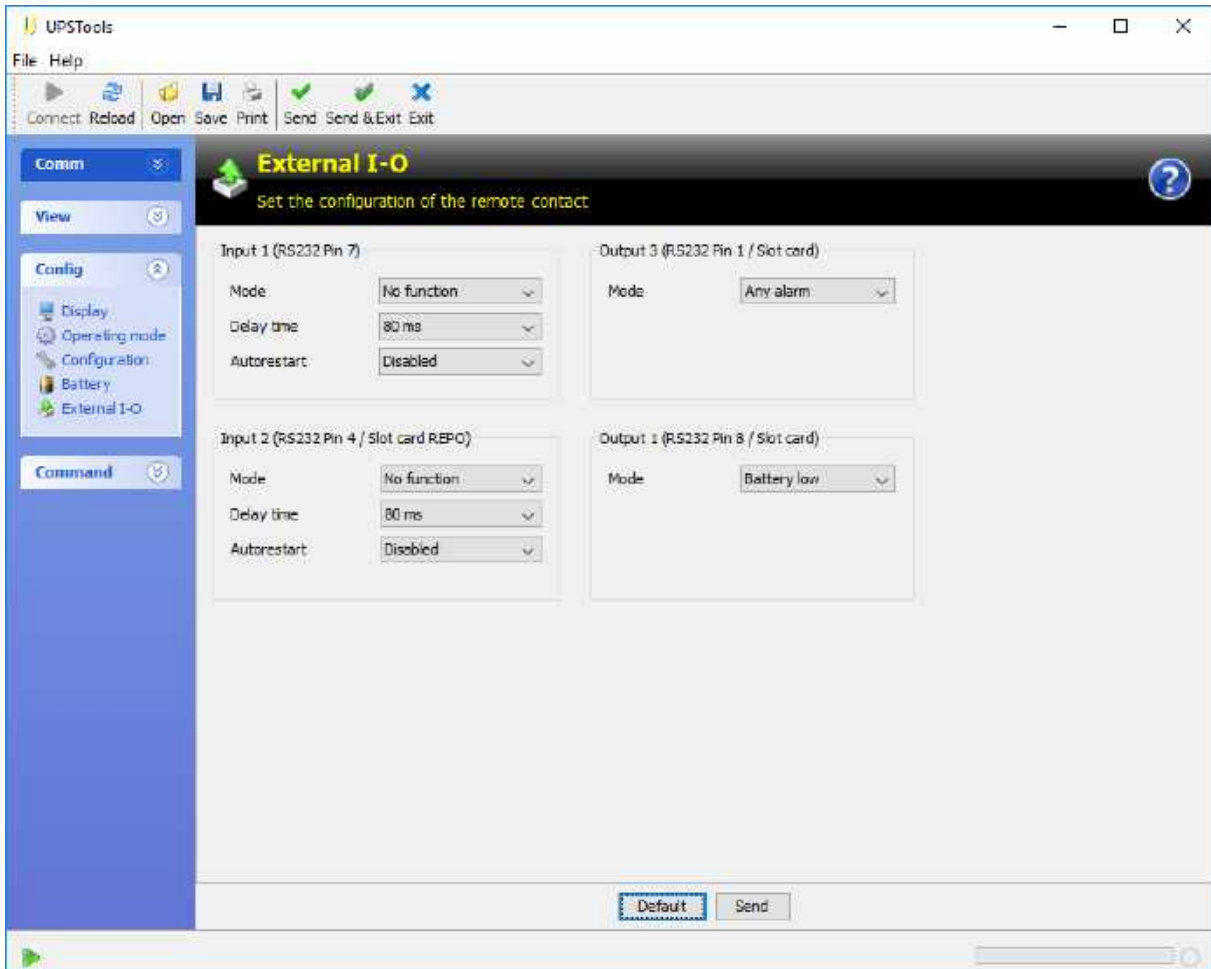

## VARIATION FOR VSD



**NOTE:** the configuration software screen is for illustrative purposes. It may vary according to the UPS series and the software version.

# SERIES SEP / SDH / SDU (4kVA)

Below are the instructions for configuring the MultiCOM 384 card, the possible settings and features of the card for the series SEP, SDH and SDU (4kVA).

SWITCH / JUMPER / TERMINALS	BASIC CONFIGURATION	OPTIONS
<b>SW5</b> (UPS MODEL)	<b>A</b>	<b>FIXED</b>
<b>JP7</b> (PIN STRIP)	<b>CLOSED</b>	<b>FIXED</b>
<b>JP8</b> (PIN STRIP)	<b>OPEN</b>	<b>FIXED</b>
<b>JP9</b> (PIN STRIP)	<b>OPEN</b>	<b>FIXED</b>
<b>JP5</b> (PIN STRIP)	<b>2-3</b>	<b>CONFIGURABLE</b>
<b>JP6</b> (PIN STRIP)	<b>1-2</b>	<b>CONFIGURABLE</b>
<b>J1</b> (4 WAYS TERMINAL)	<b>3-4</b>	<b>CONFIGURABLE</b>

### BASIC CONFIGURATION

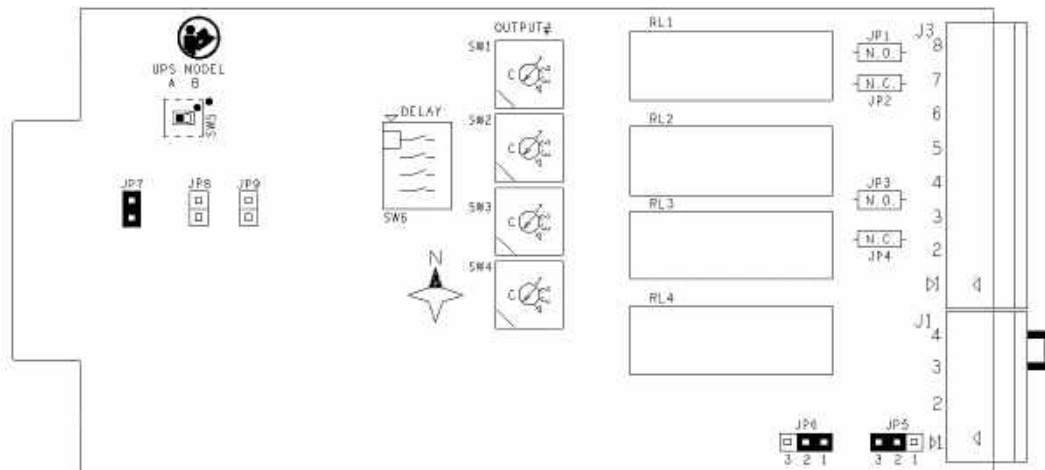

## INPUT #1

### INPUT FOR REMOTE ON

Using a normally open push button / switch connected between pin 2 and 4 of J1 (4-way terminal block), you can turn on the UPS when the contact is closed.

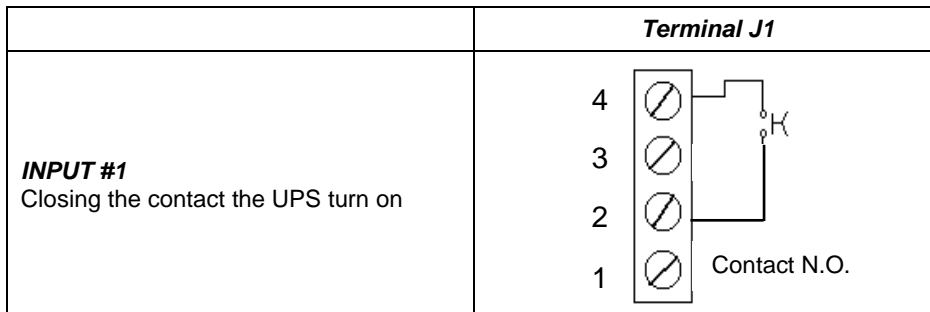

### ATTENTION:

- The UPS can be switched on only if it is powered and in STAND-BY mode.
- INPUT #1 does not work if the UPS is powered off and completely switched off.
- After installation, it is advisable to check that the UPS is switched on by the INPUT # 1 input.
- You can open the pin count between pins 2 and 4 when the UPS is started.

## INPUT #2

### INPUT FOR REMOTE OFF

You can manage INPUT #2 input either with a N.C contact than with a N.O. contact.

#### INPUT #2 with N.C. contact

Card configuration:

- Insert the jumper between pins 1 and 2 of **JP6** (3-pin strip pins on the card)

Using a normally closed push button / switch, connected between pin 3 and pin 4 of J1 (4-way terminal block), you can turn off the UPS when the contact is opened.

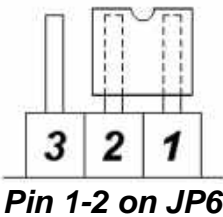
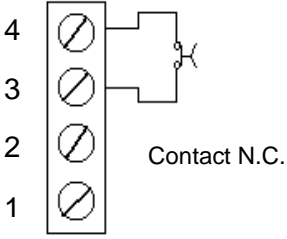
	<i>Position of the jumper on JP6</i>	<i>Terminal block J1</i>
<p><b>INPUT #2 with N.C. contact</b> Opening the contact, the UPS turn off</p>	 <p><b>Pin 1-2 on JP6</b></p>	 <p>4 3 2 1</p> <p>Contact N.C.</p>

#### INPUT #2 con contatto N.O.

Card configuration:

- Insert the jumper between pins 2 and 3 of **JP6** (3-pin strip pins on the card)

Using a normally open push button / switch, connected between pin 3 and pin 4 of J1 (4-way terminal block), you can turn off the UPS when the contact is closed.

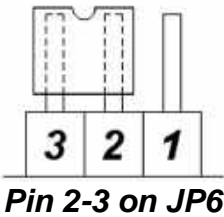
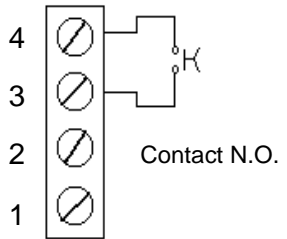
	<i>Position of the jumper on JP6</i>	<i>Terminal block J1</i>
<p><b>INPUT #2 with N.O. contact</b> Closing the contact the UPS turn off.</p>	 <p><b>Pin 2-3 on JP6</b></p>	 <p>4 3 2 1</p> <p>Contact N.O.</p>



#### **ATTENTION:**

- Setting INPUT #2 with N.C. contact, removing the jumper or 4-pole connector, if the UPS is turned on, it will switch off.
- If you insert the MultiCOM 384 card into the SLOT without the jumper on the J1 connector on the card, the UPS will switch off instantly.
- The shutdown command is an immediate REMOTE OFF command and does not remain in memory in the UPS, so you can restart the UPS again without restoring the original status of the contact.
- INPUT #2 does not replace R.E.P.O. contact of the UPS, but is an additional one, so for the UPS to work properly, do not remove the R.E.P.O. contact located on the back of the UPS.

### INPUT #3

#### INPUT FOR SERVICE BYPASS

Card configuration:

- Insert jumper between pin 1 and 2 of **JP5** (3-pin strip pins on the card)

Using a normally closed push button / switch, connected between pin 1 and pin 4 of J1 (4-way terminal block), you can activate the *Service bypass* operating mode when the contact is open.

The function remains active as long as the contact remains open.

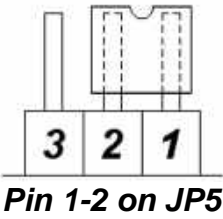
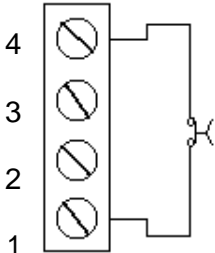
	<i>Position of the jumper on JP5</i>	<i>Terminal block J1</i>
<p><b>INPUT #3</b> Opening the UPS contact enable the configured function.</p>	 <p><b>Pin 1-2 on JP5</b></p>	 <p>Contact N.C.</p>



**ATTENTION:**

- Pay attention to the correct configuration of the JP5 jumper when connecting a contact between pins 1 and 4 on the J1 connector. The contact closure will shortcut the two pins.
- After installation, it is recommended to check the correct activation of the configured function.

#### Isolated auxiliary power supply + 12Vdc

Card configuration:

- Insert jumper between pin 2 and 3 of **JP5** (3-pin strip pins on the card)

Modifying the jumper position on the JP5 pin strip, you can get a + 12Vdc isolated auxiliary power instead of INPUT #3, useful for powering small devices such as optocouplers needed to send clean contacts to the UPS.

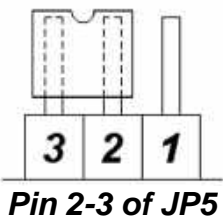
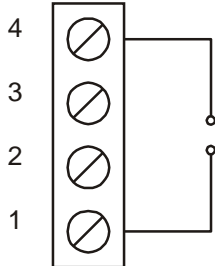
	<i>Position of the jumper on JP5</i>	<i>Terminal block J1</i>
<p><b>Isolated aux. power</b> <b>+12Vdc 100mA max</b></p>	 <p><b>Pin 2-3 of JP5</b></p>	 <p>GND +12Vdc 12Vdc ±10% max 100mA</p>



**ATTENTION:**

- Pins 1 and 4 deliver a maximum of 100mA.
- The supplied voltage is 12Vdc ± 10%.
- An absorption greater than the indicated value, or a short circuit, causes an immediate UPS shutdown due the failure of power supply for INPUT # 2 input (REMOTE OFF).

## CONFIGURATION VIA SOFTWARE OF OUTPUT

Outputs that are configurable via software are as follows:

- OUTPUT #1
- OUTPUT #3

The outputs OUTPUT #2 and OUTPUT #4 cannot be configured via software.

 **NOTE:** you can associate the same signal to multiple relays.

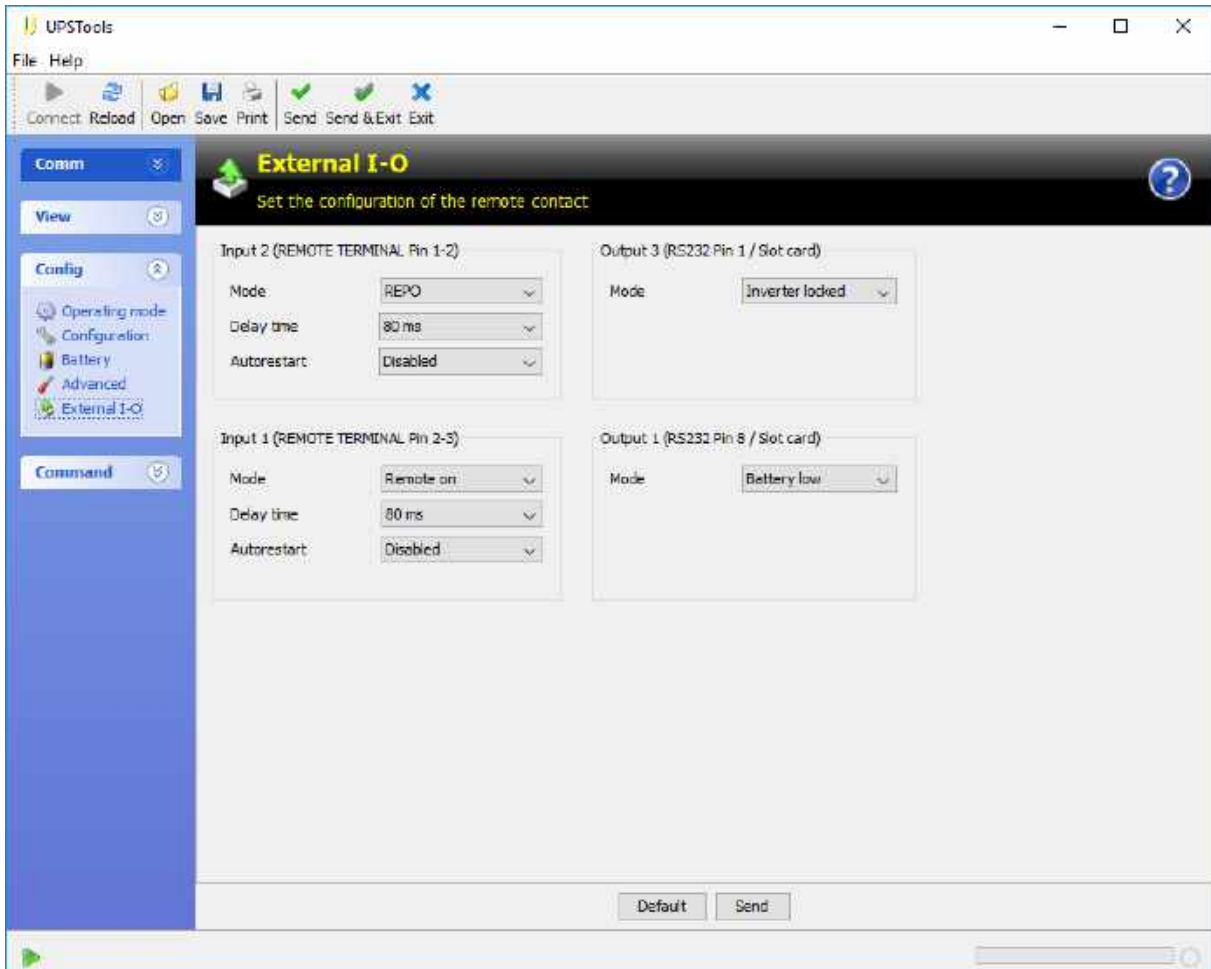

 **NOTE:** the configuration software screen is for illustrative purposes. It may vary according to the UPS series and the software version.

## SERIES SDL (3,3÷4KVA)

Below are the instructions for configuring the MultiCOM 384 card, the possible settings and features of the card for the serie SDL (3,3÷4kVA).

SWITCH / JUMPER / TERMINALS	BASIC CONFIGURATION	OPTIONS
<b>SW5</b> (UPS MODEL)	<b>A</b>	<b>FIXED</b>
<b>JP7</b> (PIN STRIP)	<b>CLOSED</b>	<b>FIXED</b>
<b>JP8</b> (PIN STRIP)	<b>OPEN</b>	<b>FIXED</b>
<b>JP9</b> (PIN STRIP)	<b>OPEN</b>	<b>FIXED</b>
<b>JP5</b> (PIN STRIP)	<b>2-3</b>	<b>CONFIGURABLE</b>
<b>JP6</b> (PIN STRIP)	<b>1-2</b>	<b>CONFIGURABLE</b>
<b>J1</b> (4 WAYS TERMINAL)	<b>3-4</b>	<b>CONFIGURABLE</b>

### BASIC CONFIGURATION

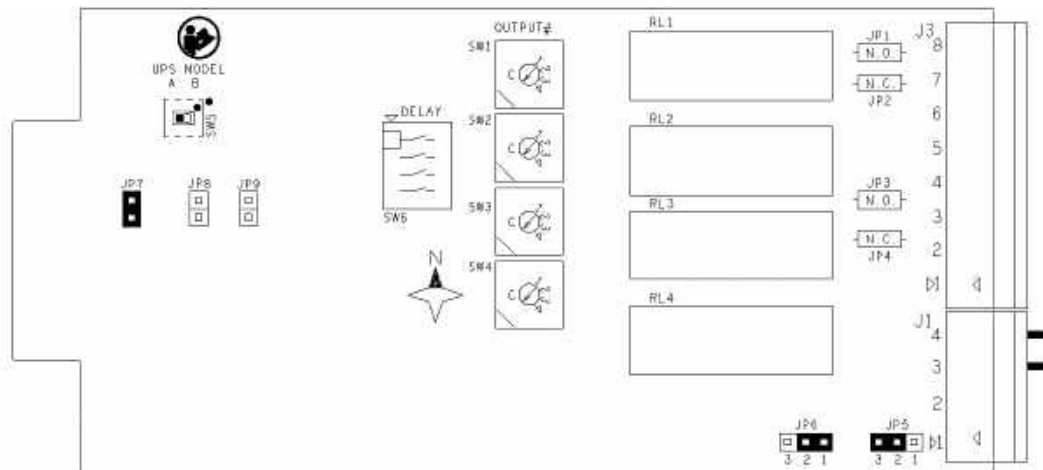

### INPUT #1

#### INPUT FOR REMOTE ON

Using a normally open push button / switch connected between pin 2 and 4 of J1 (4-way terminal block), you can turn on the UPS when the contact is closed.

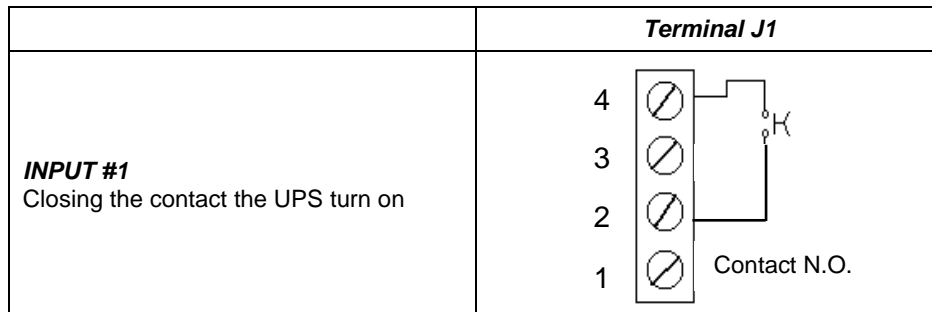

#### ATTENTION:

- The UPS can be switched on only if it is powered and in STAND-BY mode.
- INPUT #1 does not work if the UPS is powered off and completely switched off.
- After installation, it is advisable to check that the UPS is switched on by the INPUT # 1 input.
- You can open the pin count between pins 2 and 4 when the UPS is started.

## INPUT #2

### INPUT FOR REMOTE OFF

You can manage INPUT #2 input either with a N.C contact than with a N.O. contact.

#### INPUT #2 with N.C. contact

Card configuration:

- Insert the jumper between pins 1 and 2 of **JP6** (3-pin strip pins on the card).

Using a normally closed push button / switch, connected between pin 3 and pin 4 of J1 (4-way terminal block), you can turn off the UPS when the contact is opened.

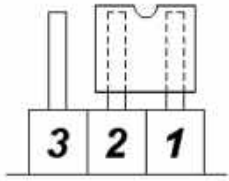
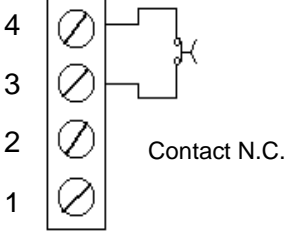
	<i>Position of the jumper on JP6</i>	<i>Terminal block J1</i>
<p><b>INPUT #2 with N.C. contact</b> Opening the contact, the UPS turn off</p>	 <p><b>Pin 1-2 on JP6</b></p>	 <p>Contact N.C.</p>

#### INPUT #2 with N.O. contact

Card configuration:

- Insert the jumper between pins 2 and 3 of **JP6** (3-pin strip pins on the card).

Using a normally open push button / switch, connected between pin 3 and pin 4 of J1 (4-way terminal block), you can turn off the UPS when the contact is closed.

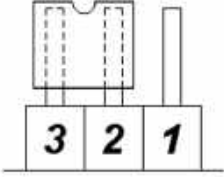
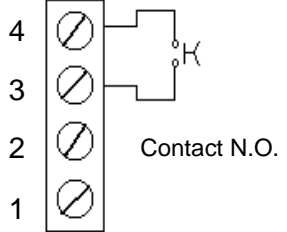
	<i>Position of the jumper on JP6</i>	<i>Terminal block J1</i>
<p><b>INPUT #2 with N.O. contact</b> Closing the contact the UPS turn off.</p>	 <p><b>Pin 2-3 on JP6</b></p>	 <p>Contact N.O.</p>



#### **ATTENTION:**

- Setting INPUT #2 with N.C. contact, removing the jumper or 4-pole connector, if the UPS is turned on, it will switch off.
- If you insert the MultiCOM 384 card into the SLOT without the jumper on the J1 connector on the card, the UPS will switch off instantly.

### INPUT #3

#### INPUT FOR SERVICE BYPASS

Card configuration:

- Insert jumper between pin 1 and 2 of **JP5** (3-pin strip pins on the card)

Using a normally closed push button / switch, connected between pin 1 and pin 4 of J1 (4-way terminal block), you can activate the *Service bypass* operating mode when the contact is open.

The function remains active as long as the contact remains open.

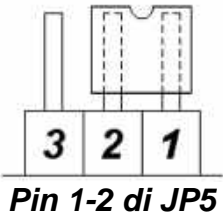
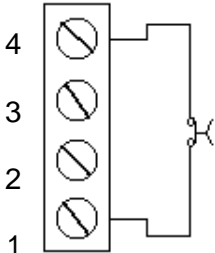
	<i>Position of the jumper on JP5</i>	<i>Terminal block J1</i>
<p><b>INPUT #3</b> Opening the UPS contact enable the configured function.</p>	 <p><b>Pin 1-2 di JP5</b></p>	 <p>4 3 2 1</p> <p>Contact N.C.</p>



#### **ATTENTION:**

- Pay attention to the correct configuration of the JP5 jumper when connecting a contact between pins 1 and 4 on the J1 connector. The contact closure will shortcut the two pins.
- After installation, it is recommended to check the correct activation of the configured function.

#### **Isolated auxiliary power supply + 12Vdc**

Card configuration:

- Insert jumper between pin 2 and 3 of **JP5** (3-pin strip pins on the card)

Modifying the jumper position on the JP5 pin strip, you can get a + 12Vdc isolated auxiliary power instead of INPUT #3, useful for powering small devices such as optocouplers needed to send clean contacts to the UPS.

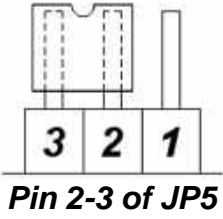
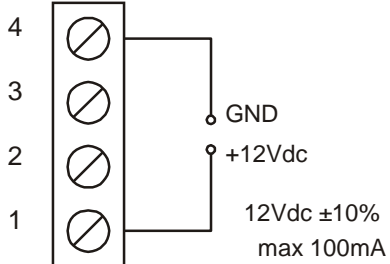
	<i>Position of the jumper on JP5</i>	<i>Terminal block J1</i>
<p><b>Isolated aux. power</b> <b>+12Vdc 100mA max</b></p>	 <p><b>Pin 2-3 of JP5</b></p>	 <p>4 3 2 1</p> <p>GND +12Vdc</p> <p>12Vdc ±10% max 100mA</p>



#### **ATTENTION:**

- Pins 1 and 4 deliver a maximum of 100mA.
- The supplied voltage is 12Vdc ± 10%.
- An absorption greater than the indicated value, or a short circuit, causes an immediate UPS shutdown due the failure of power supply INPUT # 2 input (REMOTE OFF).



## CONFIGURATION VIA SOFTWARE OF OUTPUT

Outputs that are configurable via software are as follows:

- OUTPUT #1
- OUTPUT #3

The outputs OUTPUT #2 and OUTPUT #4 cannot be configured via software.

 **NOTE:** you can associate the same signal to multiple relays.

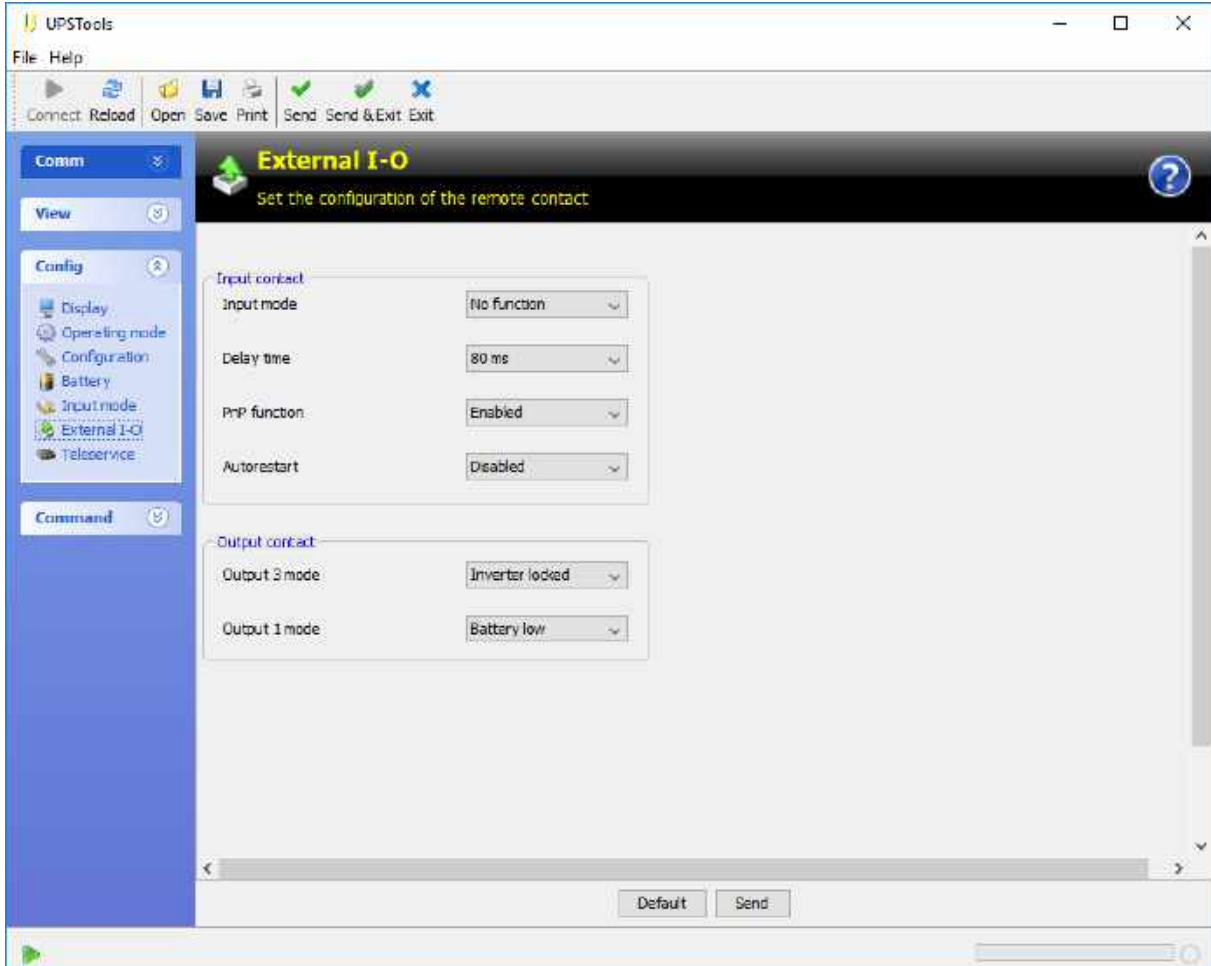

 **NOTE:** the configuration software screen is for illustrative purposes. It may vary according to the UPS series and the software version.

## SERIES SDL (5÷6kVA) / SPT / SPW

Below are the instructions for configuring the MultiCOM 384 card, the possible settings and features of the card for the series SDL (5÷6kVA) / SPT / SPW.

SWITCH / JUMPER / TERMINALS	BASIC CONFIGURATION	OPTIONS
<b>SW5</b> (UPS MODEL)	<b>A</b>	<b>FIXED</b>
<b>JP7</b> (PIN STRIP)	<b>OPEN</b>	<b>FIXED</b>
<b>JP8</b> (PIN STRIP)	<b>OPEN</b>	<b>FIXED</b>
<b>JP9</b> (PIN STRIP)	<b>OPEN</b>	<b>FIXED</b>
<b>JP5</b> (PIN STRIP)	<b>2-3</b>	<b>CONFIGURABLE</b>
<b>JP6</b> (PIN STRIP)	<b>1-2</b>	<b>CONFIGURABLE</b>
<b>J1</b> (4 WAYS TERMINAL)	<b>3-4</b>	<b>CONFIGURABLE</b>

### BASIC CONFIGURATION

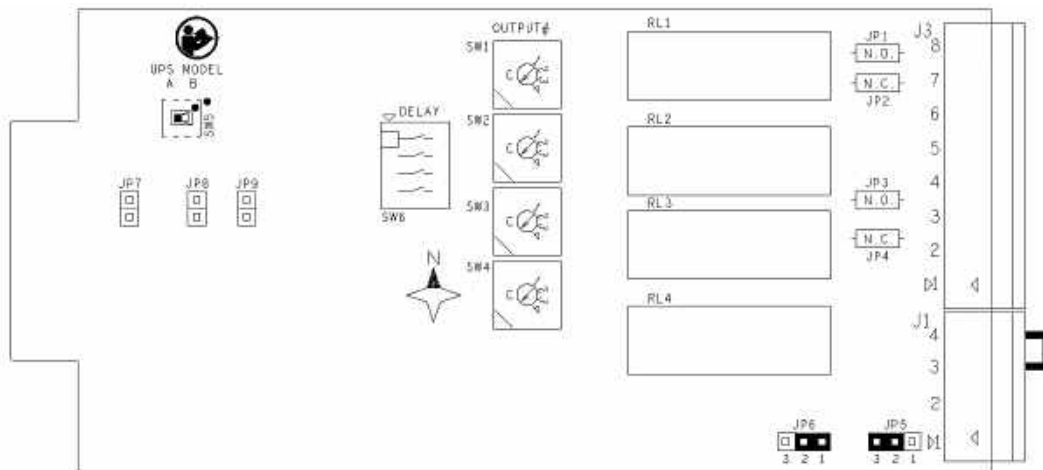

### INPUT #1

#### INPUT FOR REMOTE ON

Using a normally open push button / switch connected between pin 2 and 4 of J1 (4-way terminal block), you can turn on the UPS when the contact is closed.

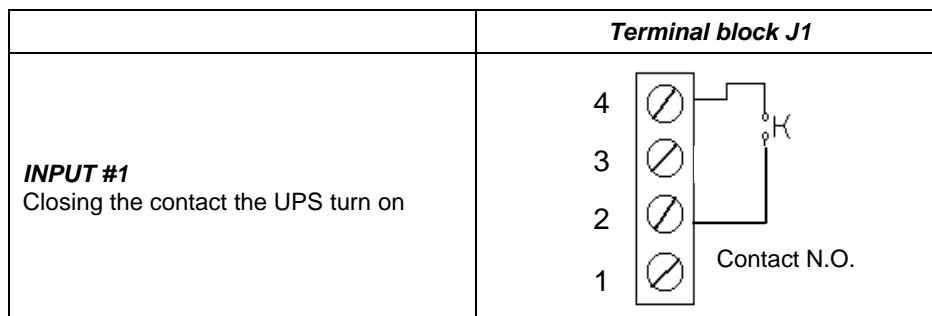

#### ATTENTION:

- The UPS can be switched on only if it is powered and in STAND-BY mode.
- INPUT #1 does not work if the UPS is powered off and completely switched off.
- After installation, it is advisable to check that the UPS is switched on by the INPUT # 1 input.
- You can open the pin count between pins 2 and 4 when the UPS is started.

## INPUT #2

### INPUT FOR REMOTE OFF

You can manage INPUT #2 input either with a N.C contact than with a N.O. contact.

#### INPUT #2 with N.C. contact

Card configuration:

- Insert the jumper between pins 1 and 2 of **JP6** (3-pin strip pins on the card).

Using a normally closed push button / switch, connected between pin 3 and pin 4 of J1 (4-way terminal block), you can turn off the UPS when the contact is opened.

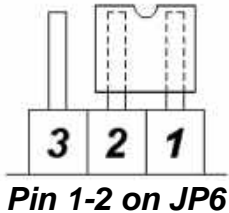
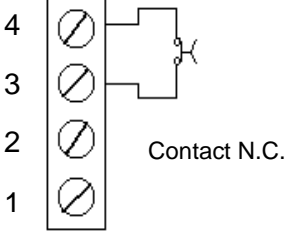
	<i>Position of the jumper on JP6</i>	<i>Terminal block J1</i>
<p><b>INPUT #2 with N.C. contact</b> Opening the contact, the UPS turn off</p>	 <p><b>Pin 1-2 on JP6</b></p>	 <p>4 3 2 1</p> <p>Contact N.C.</p>

#### INPUT #2 with N.O. contact

Card configuration:

- Insert the jumper between pins 2 and 3 of **JP6** (3-pin strip pins on the card).

Using a normally open push button / switch, connected between pin 3 and pin 4 of J1 (4-way terminal block), you can turn off the UPS when the contact is closed.

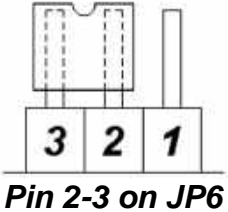
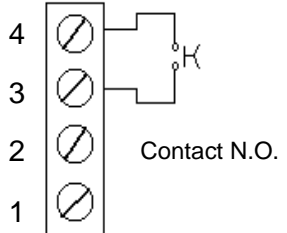
	<i>Position of the jumper on JP6</i>	<i>Terminal block J1</i>
<p><b>INPUT #2 with N.O. contact</b> Closing the contact the UPS turn off.</p>	 <p><b>Pin 2-3 on JP6</b></p>	 <p>4 3 2 1</p> <p>Contact N.O.</p>



#### **ATTENTION:**

- To handle the REMOTE OFF command from the MultiCOM 384 board, you must remove the EPO jumper from the corresponding terminal on the back of the UPS.
- Setting INPUT #2 with N.C. contact, removing the jumper or 4-pole connector, if the UPS is turned on, it will switch off.
- If you insert the MultiCOM 384 card into the SLOT without the jumper on the J1 connector on the card, the UPS will switch off instantly.

### INPUT #3

#### INPUT FOR SERVICE BYPASS

Card configuration:

- Insert jumper between pin 1 and 2 of **JP5** (3-pin strip pins on the card)

Using a normally closed push button / switch, connected between pin 1 and pin 4 of J1 (4-way terminal block), you can activate the *Service bypass* operating mode when the contact is open.

The function remains active as long as the contact remains open.

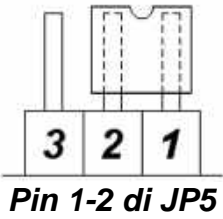
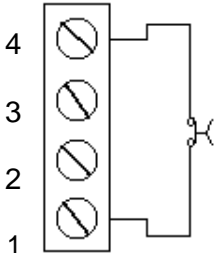
	<i>Position of the jumper on JP5</i>	<i>Terminal block J1</i>
<p><b>INPUT #3</b> Opening the UPS contact enable the configured function.</p>	 <p><b>Pin 1-2 di JP5</b></p>	 <p>Contact N.C.</p>



**ATTENTION:**

- Pay attention to the correct configuration of the JP5 jumper when connecting a contact between pins 1 and 4 on the J1 connector. The contact closure will shortcut the two pins.
- After installation, it is recommended to check the correct activation of the configured function.

#### Isolated auxiliary power supply + 12Vdc

Card configuration:

- Insert jumper between pin 2 and 3 of **JP5** (3-pin strip pins on the card)

Modifying the jumper position on the JP5 pin strip, you can get a + 12Vdc isolated auxiliary power instead of INPUT #3, useful for powering small devices such as optocouplers needed to send clean contacts to the UPS.

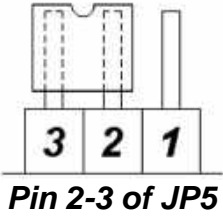
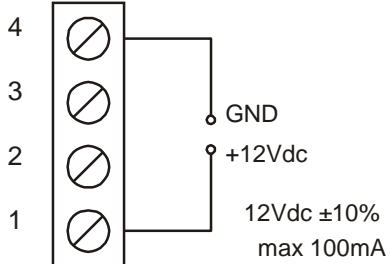
	<i>Position of the jumper on JP5</i>	<i>Terminal block J1</i>
<p><b>Isolated aux. power</b> <b>+12Vdc 100mA max</b></p>	 <p><b>Pin 2-3 of JP5</b></p>	 <p>GND +12Vdc 12Vdc ±10% max 100mA</p>



**ATTENTION:**

- Pins 1 and 4 deliver a maximum of 100mA.
- The supplied voltage is 12Vdc ± 10%.
- An absorption greater than the indicated value, or a short circuit, causes an immediate UPS shutdown due the failure of power supply INPUT # 2 input (REMOTE OFF).

## CONFIGURATION VIA SOFTWARE OF OUTPUT

Outputs that are configurable via software are as follows:

- OUTPUT #1
- OUTPUT #3

The outputs OUTPUT #2 and OUTPUT #4 cannot be configured via software.

 **NOTE:** you can associate the same signal to multiple relays.

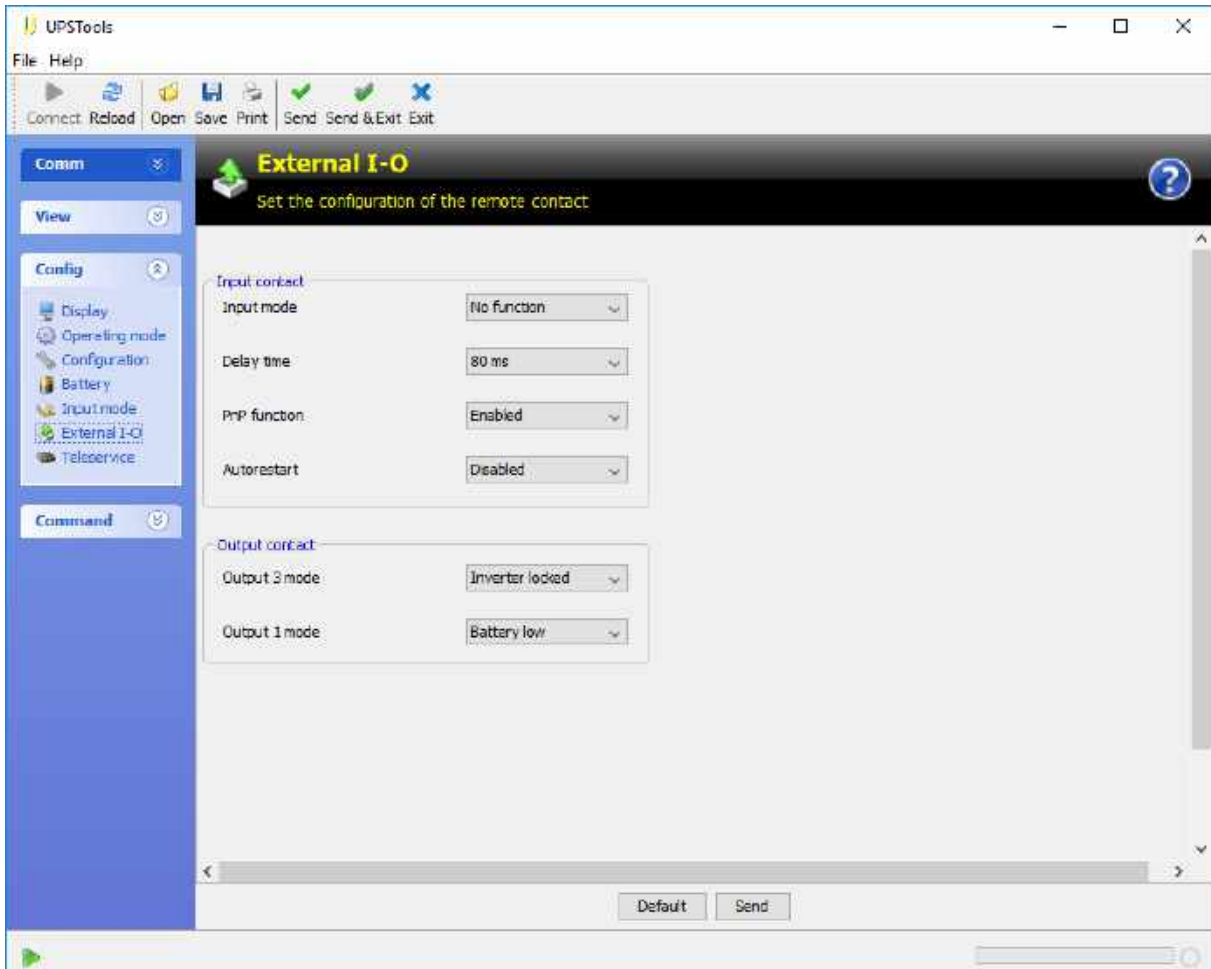

 **NOTE:** the configuration software screen is for illustrative purposes. It may vary according to the UPS series and the software version.

## SERIES SDU (5÷10kVA)

Below are the instructions for configuring the MultiCOM 384 card, the possible settings and features of the card for the series SDU (5÷10kVA).

SWITCH / JUMPER / TERMINALS	BASIC CONFIGURATION	OPTIONS
<b>SW5</b> (UPS MODEL)	<b>B</b>	<b>FIXED</b>
<b>JP7</b> (PIN STRIP)	<b>OPEN</b>	<b>FIXED</b>
<b>JP8</b> (PIN STRIP)	<b>OPEN</b>	<b>FIXED</b>
<b>JP9</b> (PIN STRIP)	<b>OPEN</b>	<b>FIXED</b>
<b>JP5</b> (PIN STRIP)	<b>2-3</b>	<b>CONFIGURABLE</b>
<b>JP6</b> (PIN STRIP)	<b>2-3</b>	<b>CONFIGURABLE</b>
<b>J1</b> (MORSETTO 4 VIE)	<b>3-4</b>	<b>CONFIGURABLE</b>

### BASIC CONFIGURATION

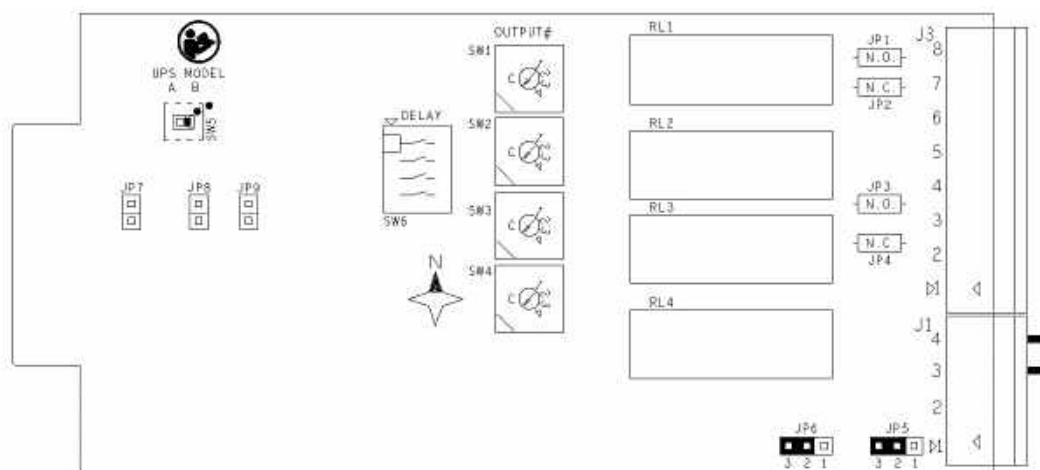

### INPUT #1

#### INPUT FOR REMOTE ON

Using a normally open push button / switch connected between J1 pin 2 and 4 (4-way terminal block), you can turn on the UPS when the contact is closed.

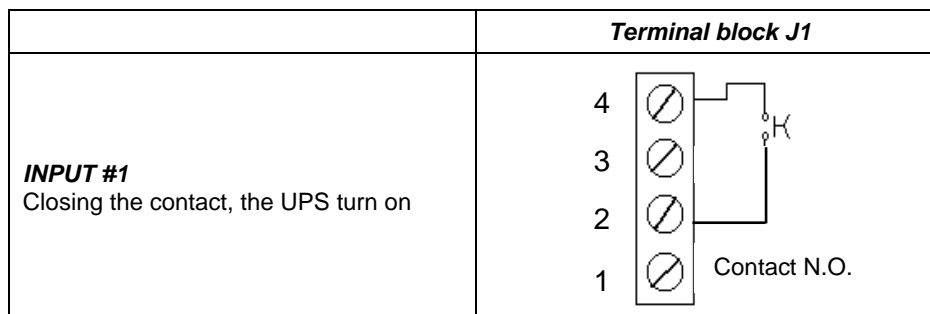

#### ATTENTION:

- The UPS can be switched on only if it is powered and in STAND-BY mode.
- INPUT #1 does not work if the UPS is powered off and completely switched off.
- After installation, it is advisable to check that the UPS is switched on by the INPUT # 1 input.
- You can open the pin count between pins 2 and 4 when the UPS is started.

## INPUT #2

### INPUT FOR REMOTE OFF

You can manage INPUT #2 input either with a N.C contact than with a N.O. contact.

#### INPUT #2 with N.C. contact

Card configuration:

- Insert the jumper between pins 2 and 3 of **JP6** (3-pin strip pins on the card)

Using a normally closed push button / switch, connected between pin 3 and pin 4 of J1 (4-way terminal block), you can turn off the UPS when the contact is opened.

You can restart the UPS again only after restoring the "normally close" condition of the contact.

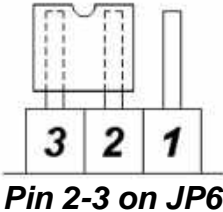
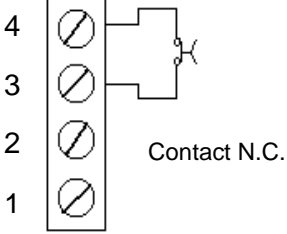
	Position of the jumper on JP6	Terminal block J1
<p><b>INPUT #2 with N.C. contact</b> Opening the contact, the UPS turn off</p>	 <p style="text-align: center;"><b>Pin 2-3 on JP6</b></p>	 <p style="text-align: center;">Contact N.C.</p>

#### INPUT #2 with N.O. contact

Card configuration:

- Insert the jumper between pins 2 and 3 of **JP6** (3-pin strip pins on the card)

Using a normally open push button / switch, connected between pin 3 and pin 4 of J1 (4-way terminal block), you can turn off the UPS when the contact is closed.

You can restart the UPS again only after restoring the "normally open" condition of the contact.

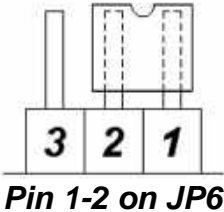
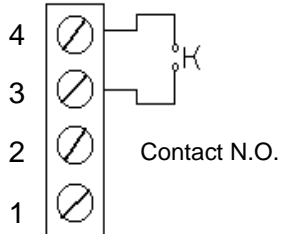
	Position of the jumper on JP6	Terminal block J1
<p><b>INPUT #2 with N.O. contact</b> Closing the contact, the UPS turn off</p>	 <p style="text-align: center;"><b>Pin 1-2 on JP6</b></p>	 <p style="text-align: center;">Contact N.O.</p>



#### **ATTENTION:**

- Setting INPUT #2 with N.C. contact, removing the jumper or 4-pole connector, if the UPS is turned on, it will switch off.
- Setting INPUT #2 with N.C. contact, inserting the MultiCOM 384 card into the SLOT without the jumper on the J1 connector on the card, the UPS will switch off instantly.
- INPUT # 2 input does not replace R.E.P.O. contact of the UPS, but is an additional one, so for the UPS to work properly, do not remove the R.E.P.O. contact located on the back of the UPS.

## INPUT #3

### CONFIGURABLE INPUT

Card Configuration:

- Insert jumper between pins 1 and 2 of **JP5** (3-pin strip pins on the card)

Using a normally closed push button / switch, connected between pin 1 and pin 4 of J1 (4-way terminal block), you can activate the function associated with the INPUT # 3 when the contact is opened.

The function associated with INPUT # 3 can be configured via the configuration software (default: **Load on bypass**).

The function remains active as long as the contact remains open.

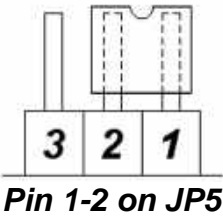
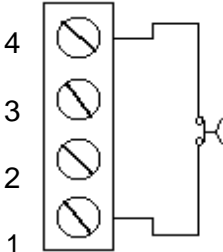
	<i>Position of the jumper on JP5</i>	<i>Terminal block J1</i>
<p><b>INPUT #3</b> Opening the UPS contact enable the configured function.</p>	 <p><b>Pin 1-2 on JP5</b></p>	 <p>Contact N.C.</p>



#### **ATTENTION:**

- **Load on bypass:** opening the contact the load power passes from inverter to bypass. With the contact open, the UPS remains in bypass operation even if the input mains is missing. If the contact is closed in the mains present condition, the UPS resumes running from inverter. If the contact is closed in a power failure condition, the UPS resumes from battery operation.
- Pay attention to the correct configuration of the JP5 jumper when connecting a jumper between pins 1 and 4 on the J1 connector. The contact closure shortcut the two pins.
- After installation, it is recommended to check the correct function of the configured function.

### Isolated auxiliary power supply + 12Vdc

Card configuration:

- Insert jumper between pin 2 and 3 of **JP5** (3-pin strip pins on the card)

Modifying the jumper position on the JP5 pin strip, you can get a +12Vdc isolated auxiliary power instead of INPUT #3, useful for powering small devices such as optocouplers needed to send clean contacts to the UPS.

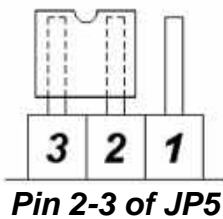
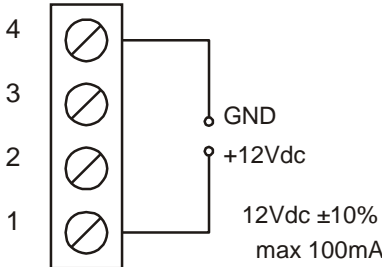
	<i>Position of the jumper on JP5</i>	<i>Terminal block J1</i>
<p><b>Isolated aux. power</b> <b>+12Vdc 100mA max</b></p>	 <p><b>Pin 2-3 of JP5</b></p>	 <p>GND +12Vdc 12Vdc ±10% max 100mA</p>



#### **ATTENTION:**

- Pins 1 and 4 deliver a maximum of 100mA.
- The supplied voltage is 12Vdc ± 10%.
- An absorption greater than the indicated value, or a short circuit, causes a bad or a not functioning of INPUT #1 and INPUT #2.



## CONFIGURATION VIA SOFTWARE OF OUTPUT

Outputs that are configurable via software are as follows:

- OUTPUT #1
- OUTPUT #2
- OUTPUT #3
- OUTPUT #4



**NOTE:** you can associate the same signal to multiple relays

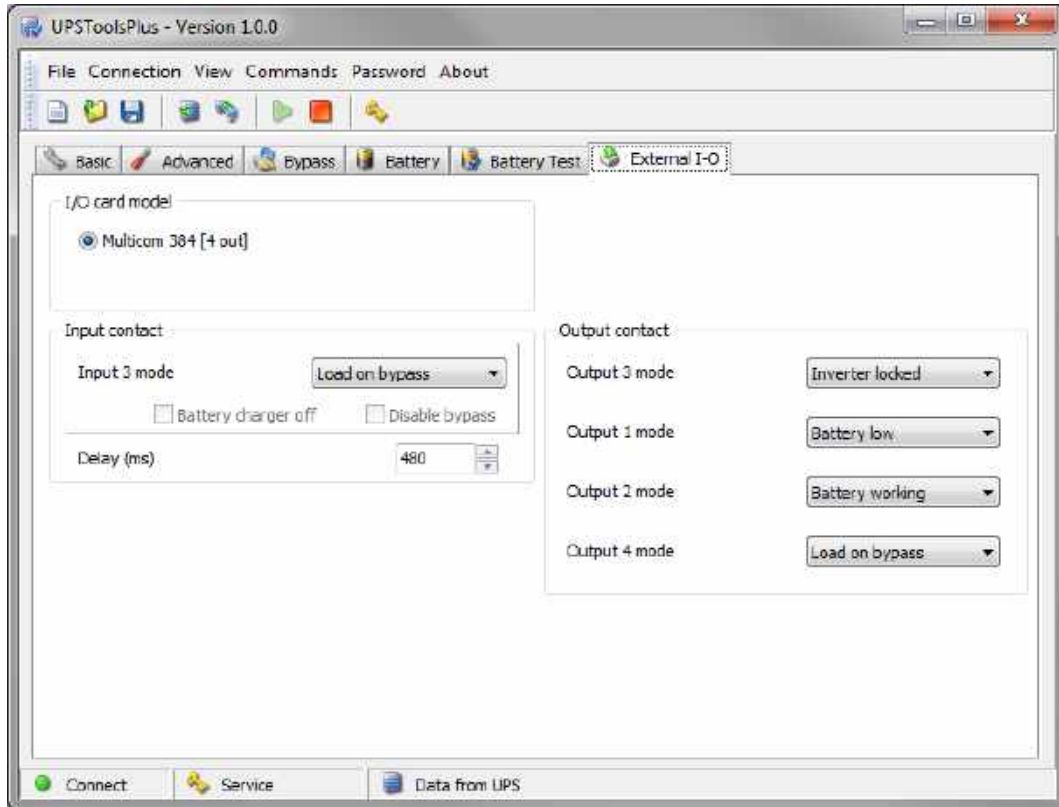

**NOTE:** the configuration software screen is for illustrative purposes. It may vary according to the UPS series and the software version.

## SERIES SPH

Below are the instructions for configuring the MultiCOM 384 card, the possible settings and features of the card for the series SPH.

SWITCH / JUMPER / TERMINALS	BASIC SETTINGS	OPTIONS
<b>SW5</b> (UPS MODEL)	<b>A</b>	<b>FIXED</b>
<b>JP7</b> (PIN STRIP)	<b>CLOSED</b>	<b>FIXED</b>
<b>JP8</b> (PIN STRIP)	<b>OPEN</b>	<b>FIXED</b>
<b>JP9</b> (PIN STRIP)	<b>OPEN</b>	<b>FIXED</b>
<b>JP5</b> (PIN STRIP)	<b>2-3</b>	<b>FIXED</b>
<b>JP6</b> (PIN STRIP)	<b>2-3</b>	<b>CONFIGURABLE</b>
<b>J1</b> (4 WAYS TERMINAL)	<b>3-4</b>	<b>CONFIGURABLE</b>

### BASIC SETTINGS

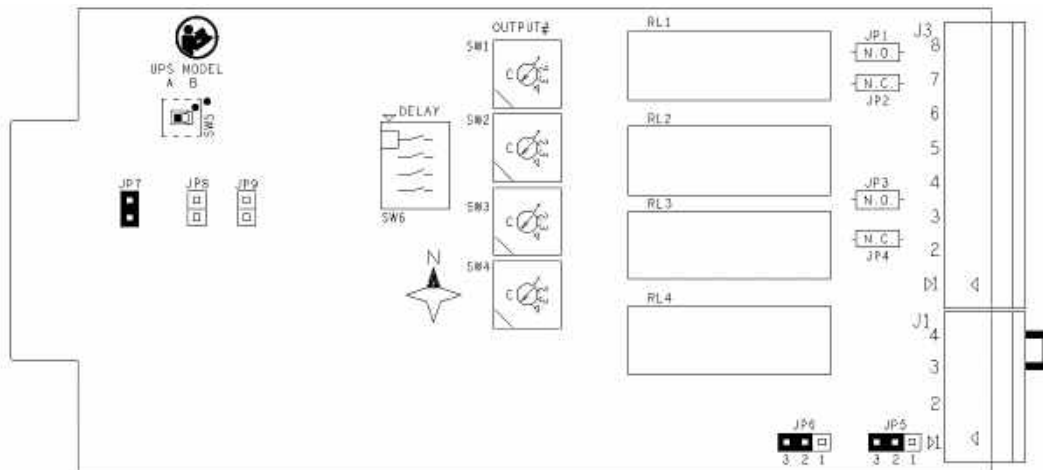

## INPUT #1

### CONFIGURABLE INPUT

You can assign different functions to the INPUT #1 via the UPS configuration software. The default configuration for INPUT #1 is NO FUNCTION (input disabled). Possible configurations are:

- **No function**
- Remote on
- Remote off
- Remote on/off

Using a normally open push button / switch connected between pin 2 and 4 of J1 (4-way terminal block), you can activate the function associated with INPUT #1 when the contact is closed.

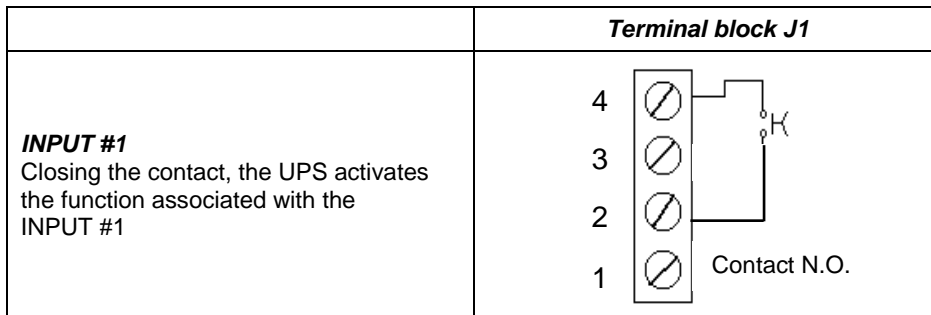

#### **ATTENTION:**

- INPUT #1 does not work if the UPS is powered off and completely switched off.
- After installation, it is advisable to check that the UPS is switched on by the INPUT # 1 input.
- With REMOTE ON, you can open the pin count between pins 2 and 4 when the UPS is started

## INPUT #2

### CONFIGURABLE INPUT

You can assign different functions to the INPUT #2 via the UPS configuration software. The default configuration for INPUT #2 is NO FUNCTION (input disabled). Possible configurations are:

- **No function**
- Remote on
- Remote off
- Remote on/off

On the MultiCOM 384 card you can manage INPUT #2 input either with a N.C contact than with a N.O. contact.

#### **INPUT #2 with N.C. contact**

Card configuration:

- Insert the jumper between pins 2 and 3 of **JP6** (3-pin strip pins on the card).

Using a normally closed push button / switch, connected between pin 3 and pin 4 of J1 (4-way terminal block), you can turn on or off the UPS (depending on the set configuration) when the contact is opened.

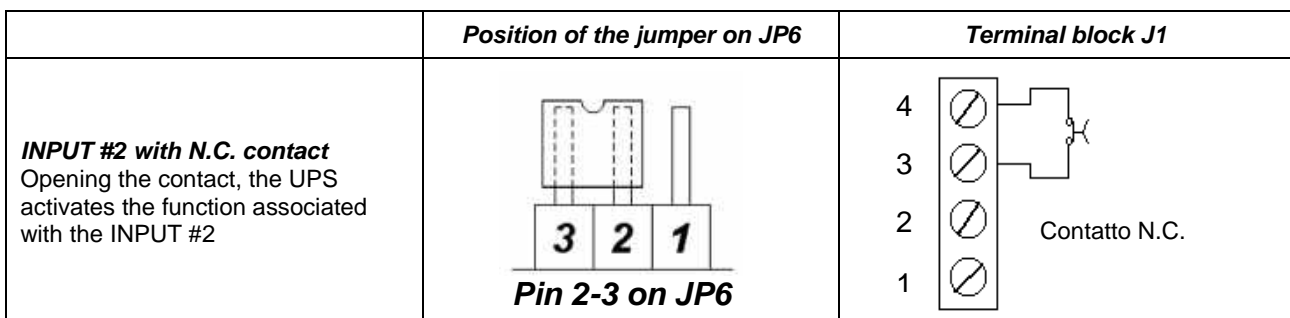

### INPUT #2 with N.O. contact

Card configuration:

- Insert the jumper between pins 1 and 2 of **JP6** (3-pin strip pins on the card)

Using a normally open push button / switch, connected between pin 3 and pin 4 of J1 (4-way terminal block), you can turn on or off the UPS (depending on the set configuration) when the contact is closed.

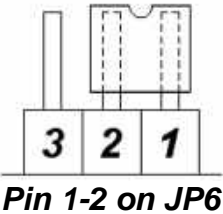
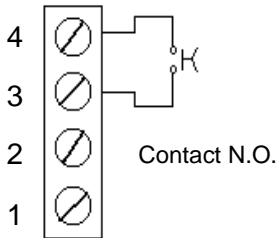
	<i>Position of the jumper on JP6</i>	<i>Terminal block J1</i>
<p><b>INPUT #2 with N.O. contact</b> Closing the contact, the UPS activates the function associated with the INPUT #2</p>	 <p><b>Pin 1-2 on JP6</b></p>	 <p>4 3 2 1</p> <p>Contact N.O.</p>



#### **ATTENTION:**

- Setting INPUT #2 with N.C. contact, removing the jumper or 4-pole connector, if the UPS is turned on, it will switch off.
- If you insert the MultiCOM 384 card into the SLOT without the jumper on the J1 connector on the card, the UPS will switch off instantly.
- The shutdown command is an immediate REMOTE OFF command and does not remain in memory in the UPS, so you can restart the UPS again without restoring the original status of the contact.
- INPUT #2 does not replace R.E.P.O. contact of the UPS, but is an additional one, so for the UPS to work properly, do not remove the R.E.P.O. contact located on the back of the UPS.

### INPUT #3

The MultiCOM 384 board does not handle the INPUT #3 in the SPH series.

### Isolated auxiliary power supply + 12Vdc

Card configuration:

- Insert jumper between pin 2 and 3 of **JP5** (3-pin strip pins on the card)

Modifying the jumper position on the JP5 pin strip, you can get a +12Vdc isolated auxiliary power instead of INPUT #3, useful for powering small devices such as optocouplers needed to send clean contacts to the UPS.

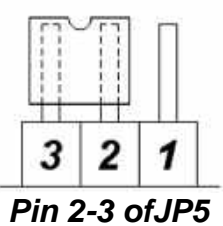
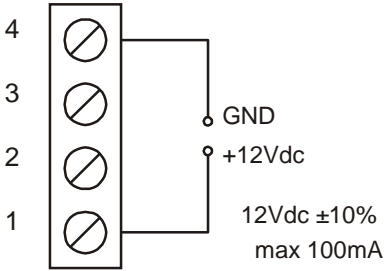
	<i>Position of the jumper on JP5</i>	<i>Terminal block J1</i>
<p><b>Isolated aux. power</b> <b>+12Vdc 100mA max</b></p>	 <p><b>Pin 2-3 of JP5</b></p>	 <p>4 3 2 1</p> <p>GND +12Vdc</p> <p>12Vdc ±10% max 100mA</p>



#### **ATTENTION:**

- Pins 1 and 4 deliver a maximum of 100mA.
- The supplied voltage is 12Vdc ± 10%.
- An absorption greater than the indicated value, or a short circuit, causes an immediate UPS shutdown due the failure of power supply for INPUT #1 and INPUT #2 inputs (configurable as REMOTE OFF).

## CONFIGURATION VIA SOFTWARE OF OUTPUT

Outputs that are configurable via software are as follows:

- OUTPUT #1
- OUTPUT #2
- OUTPUT #3
- OUTPUT #4



**ATTENTION:** by default the OUTPUT #4 is associated to OUTPUT POWERED function.



**NOTE:** you can associate the same signal to multiple relays.

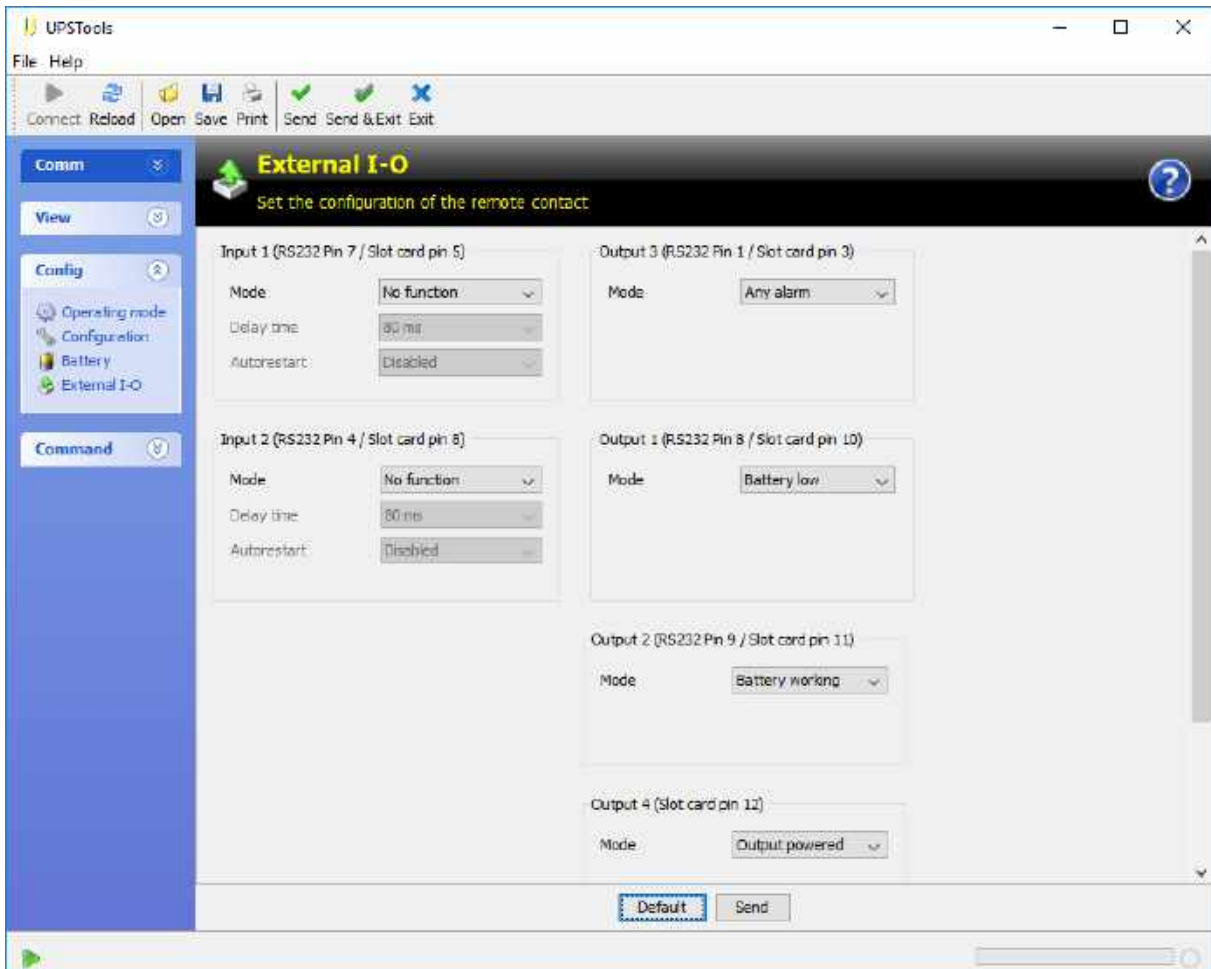

**NOTE:** the configuration software screen is for illustrative purposes. It may vary according to the UPS series and the software version.

## SERIES MST / MSM / MCT / MCM / C1T / C1M / GMI

Below are the instructions for configuring the MultiCOM 384 card, the possible settings and features of the card for the series MST / MSM / MCT / MCM / C1T / C1M / GMI.

SWITCH / JUMPER / TERMINALS	BASIC SETTINGS	OPTIONS
<b>SW5</b> (UPS MODEL)	<b>A</b>	<b>FIXED</b>
<b>JP7</b> (PIN STRIP)	<b>OPEN</b>	<b>FIXED</b>
<b>JP8</b> (PIN STRIP)	<b>OPEN</b>	<b>FIXED</b>
<b>JP9</b> (PIN STRIP)	<b>OPEN</b>	<b>FIXED</b>
<b>JP5</b> (PIN STRIP)	<b>2-3</b>	<b>CONFIGURABLE</b>
<b>JP6</b> (PIN STRIP)	<b>OPEN</b>	<b>FIXED</b>
<b>J1</b> (4 WAYS TERMINAL)	<b>3-4</b>	<b>FIXED</b>

### BASIC SETTINGS

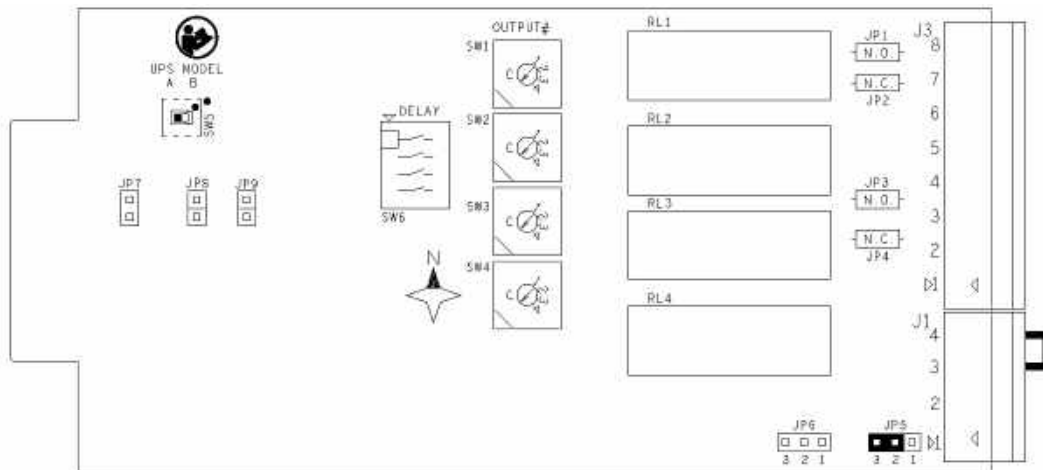

### INPUT #1

#### INPUT FOR REMOTE ON

Using a normally open push button / switch connected between pin 2 and 4 of J1 (4-way terminal block), you can turn on the UPS when the contact is closed.

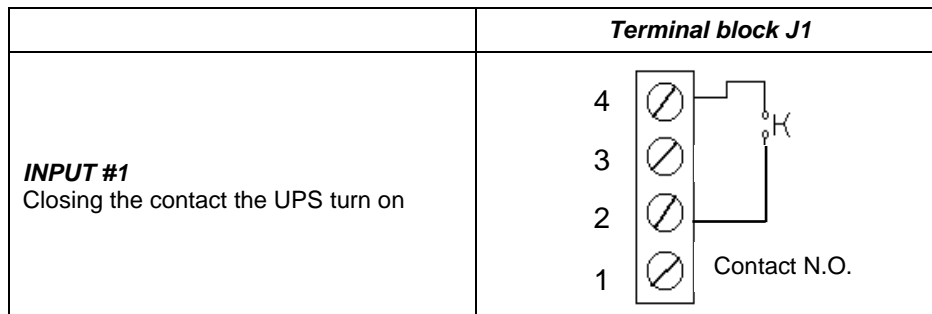

#### ATTENTION:

- The UPS can be switched on only if it is powered and in STAND-BY mode.
- INPUT #1 does not work if the UPS is powered off and completely switched off.
- After installation, it is advisable to check that the UPS is switched on by the INPUT # 1 input.
- You can open the pin count between pins 2 and 4 when the UPS is started.

## INPUT #2

The MultiCOM 384 board does not handle the INPUT #2 in the series MST / MSM / MCT / MCM / C1T / C1M / GMI.

## INPUT #3

### CONFIGURABLE INPUT

Card Configuration:

- Insert jumper between pins 1 and 2 of **JP5** (3-pin strip pins on the card)

Using a normally closed push button / switch, connected between pin 1 and pin 4 of J1 (4-way terminal block), you can activate the function associated with the INPUT #3 when the contact is opened.

The function associated with INPUT # 3 can be configured via the configuration software (default: **Load on bypass**).

The function remains active as long as the contact remains open.

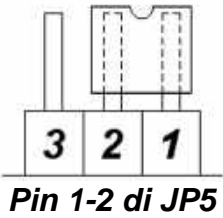
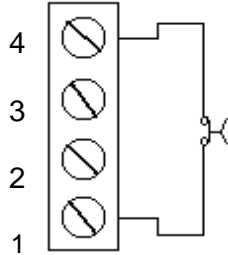
	<i>Position of the jumper on JP5</i>	<i>Terminal block J1</i>
<p><b>INPUT #3</b> Opening the UPS contact enable the configured function.</p>	 <p><b>Pin 1-2 di JP5</b></p>	 <p>4 3 2 1</p> <p>Contact N.C.</p>



#### **ATTENTION:**

- **Load on bypass:** opening the contact the load power passes from inverter to bypass. With the contact open, the UPS remains in bypass operation even if the input mains is missing. If the contact is closed in the mains present condition, the UPS resumes running from inverters. If the contact is closed in a power failure condition, the UPS resumes from battery operation.
- Pay attention to the correct configuration of the JP5 jumper when connecting a jumper between pins 1 and 4 on the J1 connector. The contact closure shortcut the two pins.
- After installation, it is recommended to check the correct function of the configured function.

### Isolated auxiliary power supply + 12Vdc

Card configuration:

- Insert jumper between pin 2 and 3 of **JP5** (3-pin strip pins on the card)

Modifying the jumper position on the JP5 pin strip, you can get a +12Vdc isolated auxiliary power instead of INPUT #3, useful for powering small devices such as optocouplers needed to send clean contacts to the UPS.

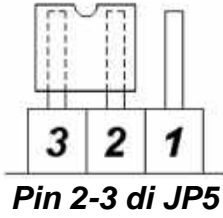
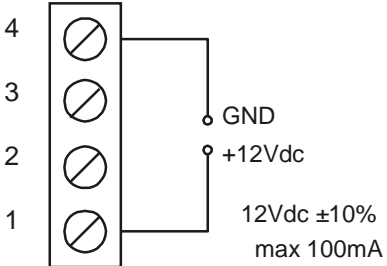
	<i>Position of the jumper on JP5</i>	<i>Terminal block J1</i>
<p><b>Isolated aux. power</b> <b>+12Vdc 100mA max</b></p>	 <p><b>Pin 2-3 di JP5</b></p>	 <p>4 3 2 1</p> <p>GND +12Vdc</p> <p>12Vdc ±10% max 100mA</p>



#### **ATTENTION:**

- Pins 1 and 4 deliver a maximum of 100mA.
- The supplied voltage is 12Vdc ± 10%.

## CONFIGURATION VIA SOFTWARE OF OUTPUT

Outputs that are configurable via software are as follows:

- OUTPUT #1
- OUTPUT #2
- OUTPUT #3
- OUTPUT #4



**NOTE:** you can associate the same signal to multiple relays.

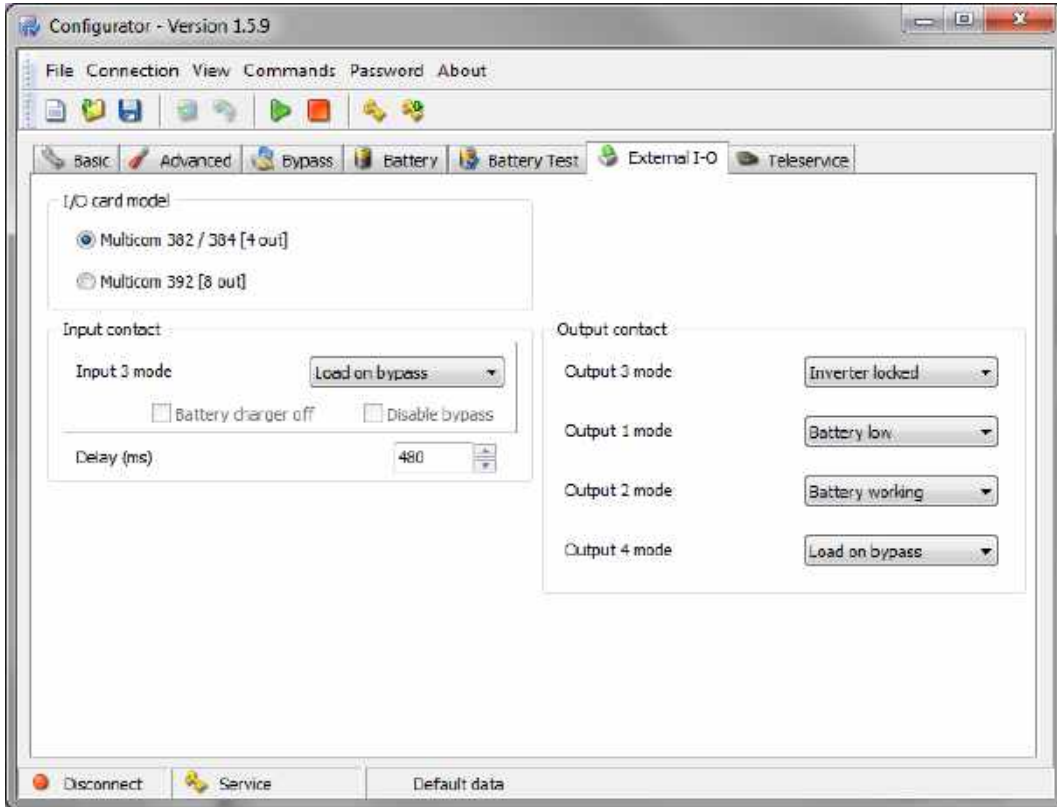

**NOTE:** the configuration software screen is for illustrative purposes. It may vary according to the UPS series and the software version.



---

## **SERIES MPW**

### **CONFIGURATION VIA SOFTWARE OF INPUT**

Inputs that are configurable via software are as follows:

- INPUT #1
- INPUT #2
- INPUT #3

### **CONFIGURATION VIA SOFTWARE OF OUTPUT**

Outputs that are configurable via software are as follows:

- OUTPUT #1
- OUTPUT #2
- OUTPUT #3
- OUTPUT #4



**NOTE:** refer to the MPW *[Advanced configuration manual](#)* for features and configuration of the card MultiCOM 384.