



User's Manual

SR100Hi Series - 100W DC UPS



No-Break™ DC UPS

STANDARD FEATURES



3 Relay Alarms-Form C

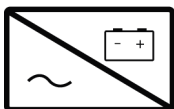

Float Charger –Lead Acid Batteries

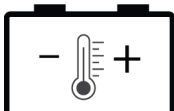

Temperature Sensor on 1.7m lead with adhesive pad: -4mV / °C /cell ±10%



ELVD : Electronic low voltage disconnect

OPTIONAL FEATURES



Comms:

- RS232
- RS485
- Modbus RTU
- SNMP V1 & Webpages



Customizable Digital I/O

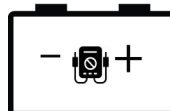

BCT: Battery Condition Test.

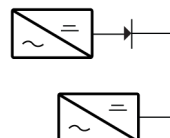

N+1 Redundancy

Table of Contents

1. SAFETY	4
2. INTRODUCTION	5
3. SR100Hi Series - SYSTEM BLOCK DIAGRAM	5
4. OPERATION OF ELECTRONIC CIRCUIT BREAKER (ECB) FOR PROTECTION OF BATTERY CIRCUIT & BATTERY	5
5. FRONT PANEL LAYOUT	6
6. CONNECTION AND INITIAL TESTING	7
7. LED INDICATION	7
8. SR100Hi– DC SETTINGS	8
9. SR100Hi– CONNECTIONS - Typical Examples	9
10. MODEL CODING AND OPTIONS	10
11. TECHNICAL SPECIFICATIONS.....	11
12. CUSTOMISED MODELS	12
13. TERMS OF WARRANTY	12

1. SAFETY

The user is responsible for ensuring that input and output wiring segregation complies with local standards and that in the use of the equipment, access is confined to operators and service personnel. A low resistance earth connection is essential to ensure safety and additionally, satisfactory EMI suppression (see below).

HAZARDOUS VOLTAGES EXIST WITHIN A POWER SUPPLY ENCLOSURE AND ANY REPAIRS MUST BE CARRIED OUT BY A QUALIFIED SERVICEPERSON.

Electrical Strength Tests

Components within the power supply responsible for providing the safety barrier between input and output are constructed to provide electrical isolation as required by the relevant standard. However EMI filtering components could be damaged as result of excessively long high voltage tests between input, output and ground. Please contact our technicians for advice regarding electric strength tests.

Earth Leakage

Where fitted, EMC suppression circuits cause earth leakage currents which may be to a maximum of 3.5mA.

Ventilation

High operating temperature is a major cause of power supply failures, for example, a 10°C rise in the operating temperature of a component will halve its expected life. Therefore always ensure that there is adequate ventilation for the equipment. Batteries in particular suffer shortened lifetimes if subjected to high ambient temperatures.

Water / Dust

Every effort must be made in the installation to minimise the risk of ingress of water or dust. Water will almost always cause instant failure. The effects of dust are slower in causing failure of electronic equipment but all electrical equipment should be cleaned free of any dust accumulation at regular intervals.

Electromagnetic Interference (EMI)

Switching power supplies and converters inherently generate electrical noise. All wiring should be as short as practicable and segregated from all equipment wiring which is sensitive to EMI. Residual noise can be reduced by looping DC wiring through ferrite cores (sleeves). These are most effective as close to the power supply as possible and as many turns of the wire taken through the core (+ and - in the same direction) as the core will accommodate.

External fuse protection

Fuses or circuit breakers must be used in all battery circuits to protect against short circuits. External fuses should be used for power supplies/chargers even though they are usually internally protected.

Connection polarity

It is critical to check the polarity carefully when connecting DC devices even with models which have non-destructive reverse polarity protection.

Glossary of terms used in our user manuals

PSU = power supply unit	BCT = battery condition test	ECB = electronic circuit breaker
ELVD = electronic low voltage disconnect	RPP = reverse polarity protection	EMI = electromagnetic interference
SNMP = Simple Network Management Protocol	EMC = Electromagnetic compatibility	DOD = depth of discharge

2. INTRODUCTION:

The **No-Break™ DC SR100Hi** switch mode power supply is designed to provide DC power to lead acid batteries for critical back up applications. No-Break™ DC UPS systems maximise the integrity of standby battery installations, whilst optimising the life and availability of back up batteries.

3. SR100Hi Series - SYSTEM BLOCK DIAGRAM

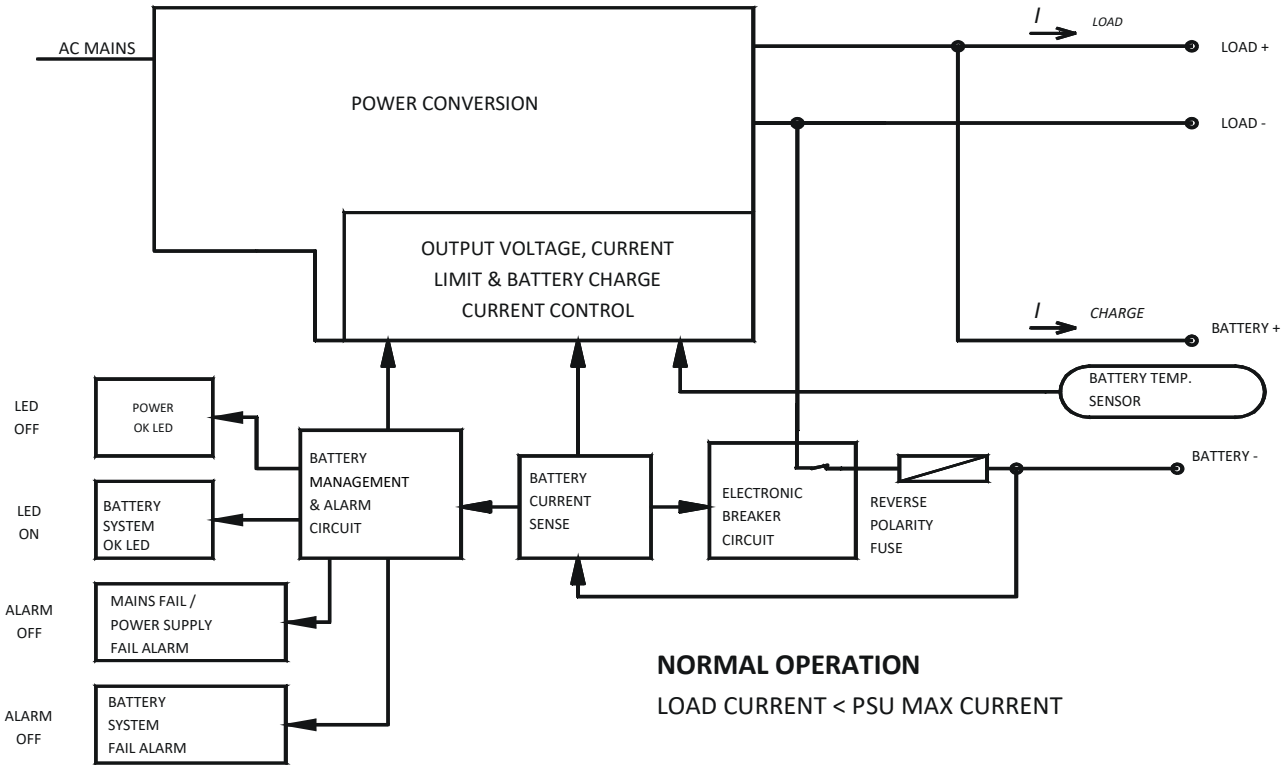

4. OPERATION OF ELECTRONIC CIRCUIT BREAKER (ECB) FOR PROTECTION OF BATTERY CIRCUIT & BATTERY

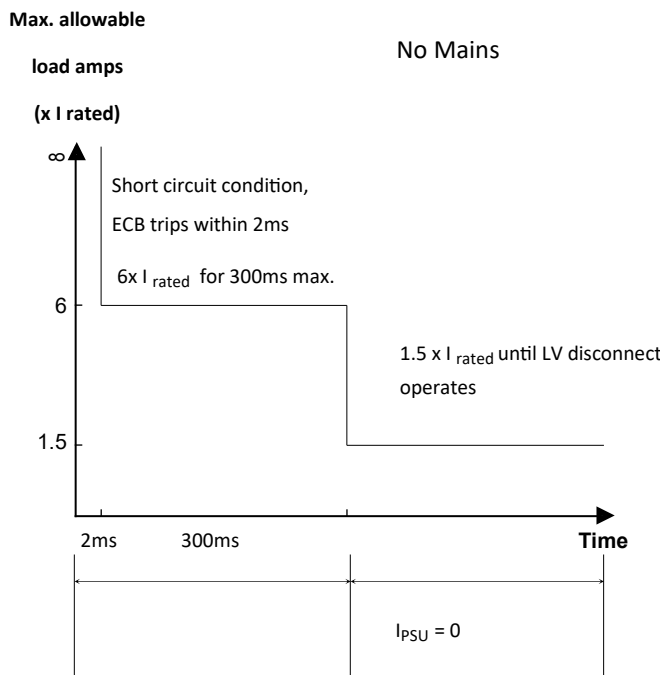

The ECB will operate on overcurrent as above & is also activated for the low voltage disconnect function on mains fail (no input power). It will reset when input power is restored, or can be manually reset by briefly shorting the **BAT-** and **LOAD-** terminals together when there is no input power.

5. FRONT PANEL LAYOUT

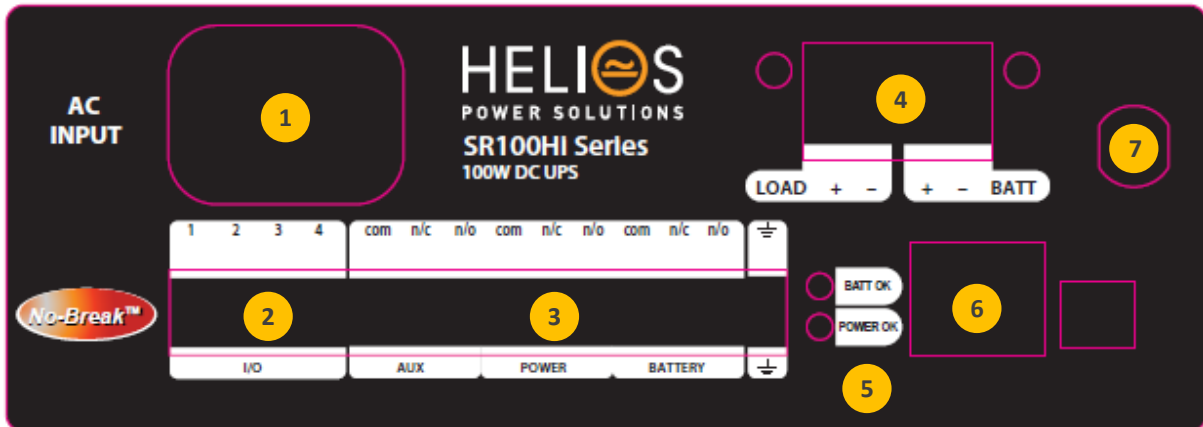

1. AC Input IEC60320 - C13 10A

2. **Digital Inputs (pins 1,2)/ Input or Output (pin 3)/ Return (pin 4)** I/O terminals are customizable and if used, the product will have a unique code.

3. Alarms Relay Form C

AUX : Activated by BCT (Battery Condition Test)

POWER:

- Loss of mains input power. This alarm has 30 seconds delay before activation upon mains failure.
- PSU fails

BATTERY:

- Battery Low: 1.8V/cell (for 2V cells) - operates only when no mains power present.
- Battery Missing or fault in battery circuit wiring (alarm does not activate for up to battery detection interval time).
- BCT fail

4. Load & Battery Connection

5. **LED indications Batt OK and Power OK** (Mimics alarm conditions above)

6. Comms Port (if installed)

- RS232 (ASCII) <https://www.heliosps.com/sr-series-downloads/#rs232-rs485-commands-sr-series>
- RS485 (ASCII) <https://www.heliosps.com/sr-series-downloads/#rs232-rs485-commands-sr-series>
- Modbus RTU <https://www.heliosps.com/sr-series-downloads/#serial-modbus-rtu-sr-series>
- SNMP, Webpages <https://www.heliosps.com/sr-series-downloads/#snmp-sr-series>

NOTES





Reverse polarity protection

















If the battery is connected in reverse, the internal battery protection fuse may be ruptured and the unit should be returned to the manufacturer for repair. If the fuse is good, the voltage measured as at step 3 above should be exactly the same on both the load and battery outputs.

6. CONNECTION AND INITIAL TESTING

1. Check input and output voltages of system, ensure that they match the equipment. All loads should be isolated.
2. Check polarity of all wiring. Place temperature sensor probe near or on batteries.
3. Plug in ac input and turn power on. Both LEDs will light up after approx. 4 sec, "BATT OK" LED will go out after another 10 secs (since there is no battery connected). DC output voltage should appear at both load and battery outputs (ensure screws are tightened down on the connector block).
4. Turn off input power.
5. Connect battery.
6. Check that ELCB (internal electronic circuit breaker) closes by shorting together the BATTERY –ve and LOAD –ve terminals for about 2-3 sec. You will hear a relay operate and both LEDs will light up. If this does not happen, there is a fault in the wiring or the internal battery protection fuse is ruptured (see Note 2 below). The battery voltage will then appear at the load terminals and the "BATTERY OK" relay energises. The "POWER OK" LED stays on for about 30 seconds.
7. Connect load wiring to **LOAD+** and **LOAD-** terminals. Check that the load does not exceed 110% of the unit. Any peak loads which are > 110% must be connected to the B+ and B-terminals.
8. Turn on ac power.
9. After the batteries are fully charged, check that the battery continues to power up the load when the input power is turned off.

7. LED INDICATION

LEGEND :  On  Flashing  Flashing Slowly  Off

Power OK LED	Battery OK LED	Power Alarm	Battery Low Alarm	Condition
		Normal	Normal	System Normal: AC power is on, PSU output is OK, battery circuit is OK and battery voltage is > V Battery Low.
		Normal	Normal	Battery detection test imminent (LED begins flashing prior to test).
		Normal	Alarm	System AC power is on, PSU output is OK but either: 1. Internal battery fuse has opened (only if battery has been reverse polarity connected), <i>or</i> 2. Battery circuit open - battery missing, or fuse / circuit breaker / wiring fault.
		Alarm	Normal	Either AC power has failed, <i>or</i> PSU has failed. Battery system is OK
		Alarm	Alarm	AC Power is off / DC has failed and battery has discharged to ≤ V Battery Low, unit will continue delivering battery current until low level initiates ELVD.
		Alarm	Alarm	AC Power is off / DC has failed and ELVD has activated and disconnected battery from load. Residual current drain on battery following ELVD <1 mA.
		Normal	Normal	Battery Condition Test is in progress: LEDs flash alternately
		Normal	Alarm	Battery Condition Unserviceable: failed to maintain terminal voltage during battery condition test

Please note that the last three conditions apply only if the battery condition test option is enabled.

8. SR100Hi– DC SETTINGS

Parameter	Default Settings					Actual settings if different from default
	12	24	30	36	48	
V nominal	12	24	30	36	48	
V output (20°C)	13.8	27.6	34.5	41.4	55.2	
BatDetect (mins)	60	60	60	60	60	
Vpres:	12.2	24.4	30.5	36.6	48.8	
Vbatl:	11	22	27.5	33	44	
Vshutd:	11.5	23	28.7	34.5	46	
Vdisco:	10	20	25	30	40	
Bccl (%)	100	100	100	100	100	
Comms	M	M	M	M	M	
BCTim (mins)	20	20	20	20	20	
CC Mins:	40	40	40	40	40	
CC Hrs:	23	23	23	23	23	
CC Days:	27	27	27	27	27	
MfiBCT:	30	30	30	30	30	

BatDetect: Time between battery detections

Vpres: Voltage threshold for battery detection and BCT. Note that if the voltage drops to this level dur-

Vshutd: Internal voltage level of the power supply during battery detection and battery condition tests.

Vbatl: **BAT LOW** alarm voltage level

Vdisco: Voltage at which the load is disconnected from the battery during mains fail

Bccl: Battery charge current limit as percentage of the rated power supply current

Comms Communication mode of PSU: F = continuous data stream of status

BCTim: Length of battery condition test

CC Mins: Time in minutes between automatically scheduled BCTs

CC Hrs: Time in hours between automatically scheduled BCTs

CC Days: Time in days between automatically scheduled BCTs

Note: The total time interval between battery condition tests (BCTs) is the sum total of the three 'CC' settings

MFiBCT: Time in minutes before the mains fail check during the BCT (only applicable to SR100)

Scheduled BCT disabled

9. SR100Hi- CONNECTIONS - Typical Examples

- Standard *No-Break™* DC charger and battery bank

This is the basic connection which is most commonly used, and provides adequate protection for the majority of systems requiring DC back up in the event of a mains power failure.

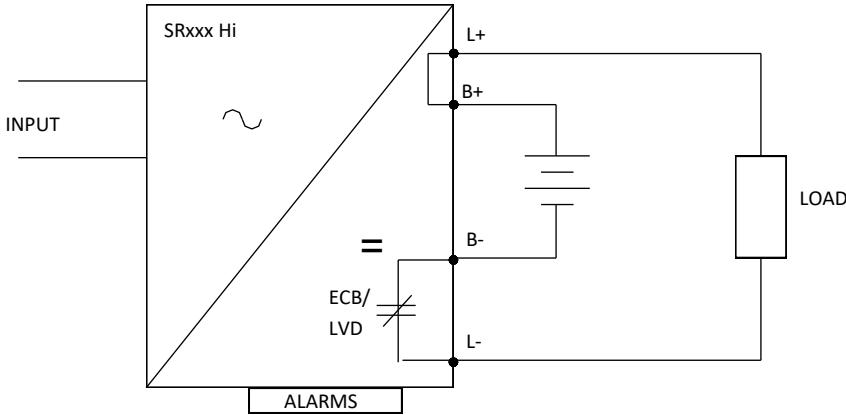

Alarms Available	
Input Fail	YES
Battery Missing	YES
Battery Low	YES
Battery Condition Test Fail	YES

Note: On stud connected output models the L+/B+ is one stud labelled “+ COMMON”

- Peak load connection using *No-Break™* DC charger

Peak loads which may exceed 1.5 x max. charger output can be connected to bypass the internal overcurrent trip circuit.

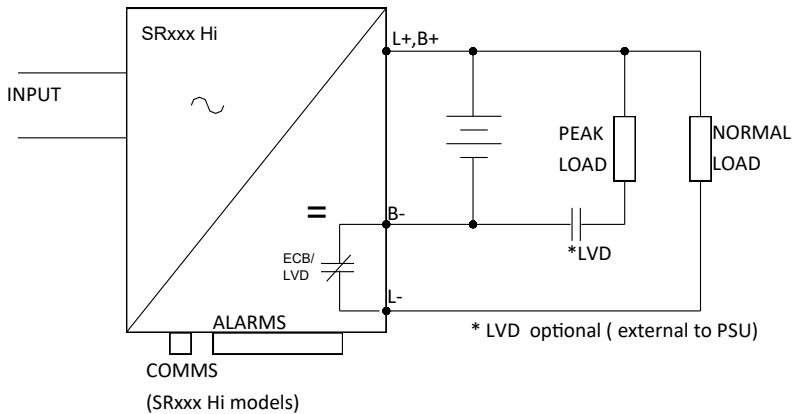

Alarms Available	
Input Fail	YES
Battery Missing	YES
Battery Low	YES
Battery Condition Test Fail	YES

- N+1 connection using two complete *No-Break™* DC systems with each one capable of supplying the loads- positive common

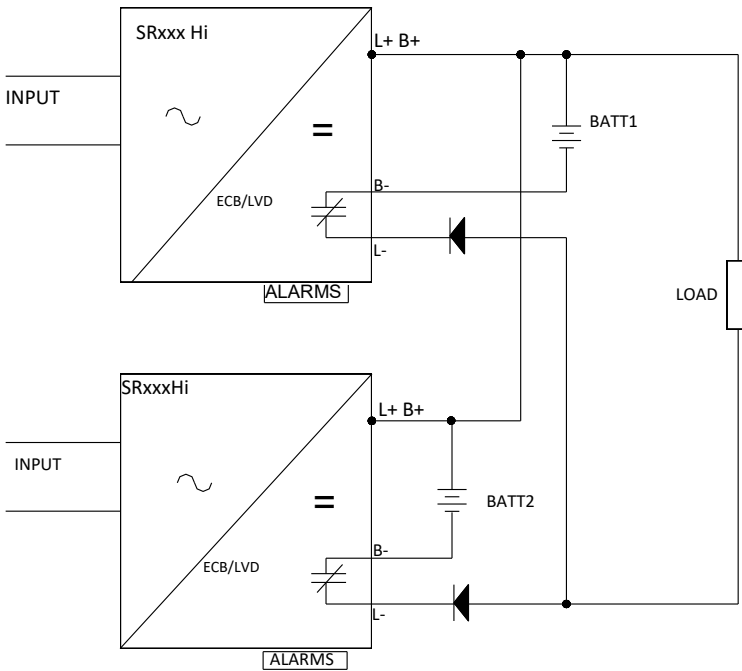

Alarms available	
Power OK	YES
Battery missing	YES
Battery low	YES
Battery condition test fail * ¹	YES

*¹ interlock circuit required for automated BCT (use SR100 Hi chargers)

10. MODEL CODING AND OPTIONS

SR100Hi 12 T X -485+

Optional Interface Port

485 = RS485 232 = RS232 LAN+=SNMP-Webpages 485+=Modbus RTU

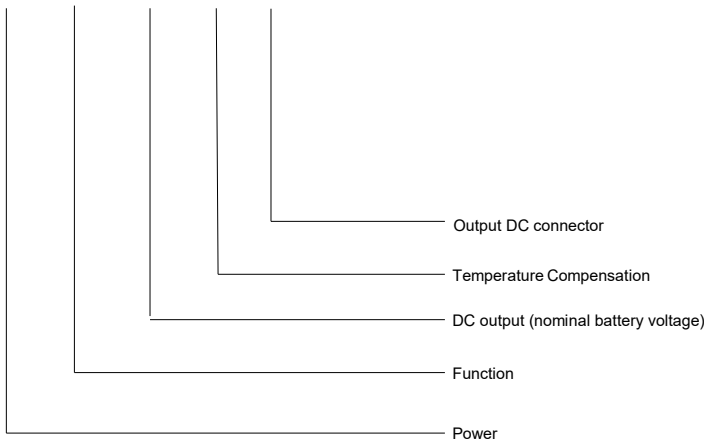

X = Pluggable connector

T = Yes Blank = No

12, 24, 30, 36, 48V

HL = DC PSU/charger - 2 terminal output

Hi = *No-Break™* DC UPS - 3 terminal output (separate battery output)

100W

11. Technical Specifications

Output power	100W
Input Voltage	180V - 264VAC 45-65Hz
Output Voltages	12V, 24V, 30V, 36V, 48 VDC
Voltage Adj. Range	85% - 120% of Vnominal
Overcurrent protection	Constant current limit under overload and short circuit conditions
Isolation	Input – earth – 2.5KVdc Output – earth - 500Vdc
Efficiency	> 85%
Operating temperature	-20 to 50 °C ambient at full load
Humidity	0 - 95% relative humidity non - condensing
Cooling	Natural convection
LVD	Low Voltage Disconnect
LED Indication	Green: Batt OK Green: Power OK
Alarms Relay	Form C contacts 30VDC,2A/110VDC,0.3A,125VAC, 0.5A AUX (Activated by BCT) POWER (main fails, PSU fails) BATTERY (batt missing , batt low, BCT fail)
Temp. Compensation	Temperature sensor on 1.7m lead with adhesive pad: -4mV/ °C / cell ± 10%
Battery Charge Current Limit	Customizable on request.
Reverse Polarity	Battery reverse connection will open internal fuse (and produce alarm)
Battery Monitoring	Detects for presence of battery on start up, then every 60 minutes when charge current < 200mA
Battery Circuit Protection	Electronic circuit breaker (ECB) operates under the following conditions:
	- <i>Low Battery Volts:</i> Battery Voltage drops to 1.67V/cell
	<i>Overload:</i> Max load must not exceed 110% of rated current. Peak loads must be connected to B+ & B– terminals. Not suitable for N+1 connection.
	<i>Short Circuit:</i> <2ms, backed up by fuse
Line Regulation	< 0.04% over AC input range
Load Regulation	< 0.5% open circuit to 100 % load
Noise	< 0.3%
Thermal Protection	Yes, self-resetting
Hold-up Time	15 - 20 ms (nom - max. Vin) without battery

AC input connector	IEC60320— C13 10A input socket (similar to PCs etc)
DC Connections	Plug-in style socket & mating screw terminal block: (max. wire 2.5mm ² / way)
Alarm connections	Plug in screw terminal block
Enclosure	Zinc plated & powder coated steel
Dimensions	147W x 177D x 62H (± 1mm)
Weight	0.95 Kg

STANDARDS

EMC	To CISPR 22 / EN55022 class A
Safety	To IEC950 / EN60950 / AS/NZS3260

