

**3**  
YEARS  
WARRANTY

ROHS  
COMPLIANT

REACH  
COMPLIANT

+85°C  
-40°C  
AMBIENT TEMP.



Automation



Datacom



IPC



Industry



Measurement



Telecom



Automobile



Boat



Charger



Medical



PV



Railway

UL US CB CE FC

PFC  
Integrated POWER SAVE

3000  
VAC  
Reinforced  
Insulation

ADJ.  
Output  
Voltage

Internal  
EN55032  
Class  
Filter **B**

LOW  
Leakage  
Current

LOW  
Standby  
Power

Operating  
Altitude  
5000  
meter

POWER  
GOOD

Protection  
Class I  
Class II

REMOTE  
ON  
OFF

OCP

OTP

OVP

SCP

### PART NUMBER STRUCTURE

T	A	H	450	U	S	12	□	-	F2	□
Application	Package Code	Dimension Code	Output Power (W)	Input Voltage (VAC)	Output Quantity	Output Voltage (VDC)	Protection Type		Option	Conformal Coating Option
Industry Application	A: Open type E: Enclosed type			U: Universal 85 ~ 264VAC	S: Single	12: 12V 15: 15V 24: 24V 28: 28V 36: 36V 48: 48V 53: 53V	Blank: CLASS I B: CLASS II		Blank: Fan connector with fixed fan speed control. Y: Fan connector with variable fan speed control.  For TEH450 only: Fixed fan speed F1: Fan 1, fan on the top F2: Fan 2, fan on the side  Variable fan speed Y1: Fan 1, fan on the top Y2: Fan 2, fan on the side	Blank: None R: Conformal Coating

**TECHNICAL SPECIFICATION** All specifications are typical at 230VAC input, full load and 25°C unless otherwise noted

Model Number	Input Range	Output Voltage	Output Current @ 230VAC				Input Power @ No Load	Efficiency	Maximum Capacitor Load
			Natural convection	Conduction cooling	Forced air cooling				
					21 CFM External Fan	Internal Fan			
VAC	VDC	A	A	A	A	W	%	µF	
TAH450US12(-Y)	85 ~ 264	12	20.8	23.3	37.5	---	0.3	91	31250
TEH450US12(-Y)	85 ~ 264	12	20.8	23.3	37.5	---	0.3	91	31250
TEH450US12-F1(Y1)	85 ~ 264	12	---	---	---	37.5	0.4	91	31250
TEH450US12-F2(Y2)	85 ~ 264	12	---	---	---	37.5	0.4	91	31250
TAH450US15(-Y)	85 ~ 264	15	16.6	18.6	30.0	---	0.5	92	20000
TEH450US15(-Y)	85 ~ 264	15	16.6	18.6	30.0	---	0.5	92	20000
TEH450US15-F1(Y1)	85 ~ 264	15	---	---	---	30.0	0.8	92	20000
TEH450US15-F2(Y2)	85 ~ 264	15	---	---	---	30.0	0.8	92	20000
TAH450US24(-Y)	85 ~ 264	24	13.3	14.55	18.75	---	0.5	93	7820
TEH450US24(-Y)	85 ~ 264	24	13.3	14.55	18.75	---	0.5	93	7820
TEH450US24-F1(Y1)	85 ~ 264	24	---	---	---	18.75	0.8	93	7820
TEH450US24-F2(Y2)	85 ~ 264	24	---	---	---	18.75	0.8	93	7820
TAH450US28(-Y)	85 ~ 264	28	11.4	12.5	16.1	---	0.5	93	5750
TEH450US28(-Y)	85 ~ 264	28	11.4	12.5	16.1	---	0.5	93	5750
TEH450US28-F1(Y1)	85 ~ 264	28	---	---	---	16.1	0.8	93	5750
TEH450US28-F2(Y2)	85 ~ 264	28	---	---	---	16.1	0.8	93	5750
TAH450US36(-Y)	85 ~ 264	36	8.9	9.72	12.5	---	0.5	93	3500
TEH450US36(-Y)	85 ~ 264	36	8.9	9.72	12.5	---	0.5	93	3500
TEH450US36-F1(Y1)	85 ~ 264	36	---	---	---	12.5	0.8	93	3500
TEH450US36-F2(Y2)	85 ~ 264	36	---	---	---	12.5	0.8	93	3500
TAH450US48(-Y)	85 ~ 264	48	6.65	7.3	9.4	---	0.5	94	1960
TEH450US48(-Y)	85 ~ 264	48	6.65	7.3	9.4	---	0.5	94	1960
TEH450US48-F1(Y1)	85 ~ 264	48	---	---	---	9.4	0.8	94	1960
TEH450US48-F2(Y2)	85 ~ 264	48	---	---	---	9.4	0.8	94	1960
TAH450US53(-Y)	85 ~ 264	53	6.05	6.6	8.55	---	0.5	94	1600
TEH450US53(-Y)	85 ~ 264	53	6.05	6.6	8.55	---	0.5	94	1600
TEH450US53-F1(Y1)	85 ~ 264	53	---	---	---	8.55	0.8	94	1600
TEH450US53-F2(Y2)	85 ~ 264	53	---	---	---	8.55	0.8	94	1600

INPUT SPECIFICATIONS						
Parameter	Conditions			Min.	Typ.	Max. Unit
Operating input voltage range	AC input			85		264 VAC
	DC input			120		370 VDC
Input frequency	AC input			47		63 Hz
Input current	100VAC and Full Load					5.8 A
	240VAC and Full Load					2.4 A
No load input power	230VAC	TAH(-Y), THE(-Y)	12Vout		0.3	Watts
			others		0.5	
		TEH -F□(Y□)	12Vout		0.5	
			others		0.8	
Leakage current	264VAC				300	µA
Power Factor				0.95		
Start up time						2000 ms
Rise time					30	ms
Hold up time	115VAC and Full Load				14	ms
Input inrush current	230VAC					100 A
Input protection	Internal fuse in line and neutral					T6.3A/250VAC
Main output remote control	Positive Logic Referenced to "-Control" *Standby power always present	Main power ON		Open or 3 ~ 12 VDC		
		Main power OFF		Short or 0 ~ 1.2VDC		
		Input current of Control		-0.5	1	mA

### OUTPUT SPECIFICATIONS

Parameter	Conditions		Min.	Typ.	Max.	Unit
Output power	Forced air cooling	All			450	Watts
		Conduction cooling @ 230VAC	12Vout, 15Vout others		280 350	
	Natural convection @ 230VAC	12Vout, 15Vout others		250 320		
		*Please refer to the derating curve for detailed rating.				
Initial set voltage accuracy	230VAC and Full Load		-1.0		+1.0	%
Line regulation	Low Line to High Line at Full Load		-0.2		+0.2	%
Load regulation	No Load to Full Load		-0.5		+0.5	%
	10% Load to 90% Load		-0.4		+0.4	
Voltage adjustability	Maximum output deviation is inclusive of remote sense		-8		+8	%
Minimum load				0		%
Ripple and noise	Measured by 20MHz bandwidth					mVp-p
	With a 1µF/25V 1206 X7R MLCC	12Vout		250		
		15Vout		300		
	With a 1µF/50V 1206 X7R MLCC	24Vout		240		
28Vout			280			
36Vout			360			
With a 0.1µF/100V 1206 X7R MLCC	48Vout		480			
	53Vout		530			
Temperature coefficient			-0.02		+0.02	%/°C
Transient response	Load step from 50 ~ 75% change at 2.5A/µs	Peak deviation		3		% Vout
		Recovery time		600		µs
Over voltage protection	% of Vout(nom); Latch mode		110		135	%
Over load protection	% of maximum lout rated; Hiccup mode		115		155	%
Short circuit protection	Protection level 1 (nominal) Protection level 2 (instantaneous high current)		Continuous, automatic recovery			Latch
Standby power supply	Always present when AC supplied					5V / 2000mA
Fan power supply	Fixed fan speed function					12V / 500mA
Main output Power Good signal	Referenced to "GND"	Power good Power off				Low Open collector

### GENERAL SPECIFICATIONS

Parameter	Conditions		Min.	Typ.	Max.	Unit
Isolation voltage	1 minute (Reinforced insulation)	Input to Output Input (Output) to F.G.	3000 2000			VAC
Isolation resistance	500VDC		0.1			GΩ
Switching frequency	230VAC, Full load			75		kHz
				65		
Safety approvals	IEC/ EN/ UL 60950-1, 62368-1					UL:E193009 CB:UL(Demko)
Weight	TAH(-Y)					462g(16.29oz)
	TEH(-Y)					504g(17.77oz)
	TEH -F1(Y1)					524g(18.48oz)
	TEH -F2(Y2)					552g(19.47oz)
MTBF	MIL-HDBK-217F Ta=25°C, Full load					4.093 x 10 <sup>5</sup> hrs

### ENVIRONMENTAL SPECIFICATIONS

Parameter	Conditions		Min.	Typ.	Max.	Unit
Operating ambient temperature	With derating	TAH(-Y), TEH(-Y)	-40		+85	°C
		TEH -F□(Y□)	-40		+80	
Storage temperature range		TAH(-Y), TEH(-Y)	-40		+85	°C
		TEH -F□(Y□)	-40		+80	
Over temperature protection	Internal thermistor ; Latch mode		110		125	°C
Operating altitude	With derating					5000 m
Shock						IEC60068-2-27
Vibration						IEC60068-2-6
Relative humidity	Non-condensing					5% to 95% RH

### EMC SPECIFICATIONS

Parameter	Conditions	Level
EMI	EN55011, EN55032 and FCC Part 15  For optimum EMI performance, the power supply should be mounted to a metal plate grounded to all 4 mounting holes of the power supply. To comply with safety standards, this plate must be properly grounded to protective earth.	Conducted Class B Radiated Class A
Harmonic currents	EN61000-3-2 Full Load	Class A and D
Voltage flicker	EN61000-3-3	
ESD	EN61000-4-2 Air ± 15kV and Contact ± 8kV	Perf. Criteria A
Radiated immunity	EN61000-4-3 3 V/m	Perf. Criteria A
Fast transient	EN61000-4-4 ± 2kV	Perf. Criteria A
Surge	EN61000-4-5 DM ± 1kV and CM ± 2kV	Perf. Criteria A
Conducted immunity	EN61000-4-6 20 Vr.m.s	Perf. Criteria A
Power frequency magnetic field	EN61000-4-8 30 A/m	Perf. Criteria A
Dip and interruptions	EN61000-4-11 and EN55024	

### CHARACTERISTIC CURVE

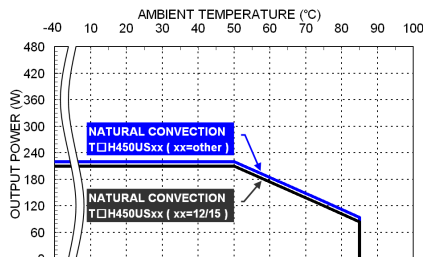

Derating Curve vs. Ambient Temperature  
Vin=115VAC and Natural convection

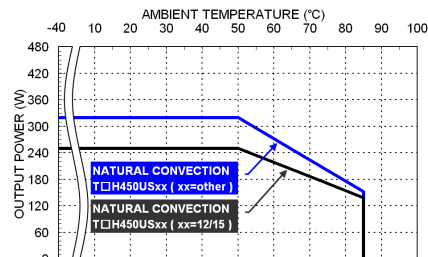

Derating Curve vs. Ambient Temperature  
Vin=230VAC and Natural convection

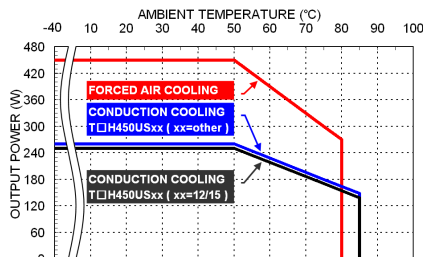

Derating Curve vs. Ambient Temperature  
Vin=115VAC and Conduction cooling tested by 43x24.8x0.12cm plate  
Forced air cooling with 21CFM (External Fan)

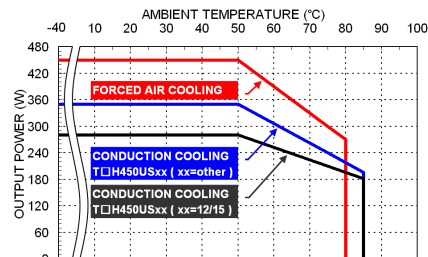

Derating Curve vs. Ambient Temperature  
Vin=230VAC and Conduction cooling tested by 43x24.8x0.12cm plate  
Forced air cooling with 21CFM (External Fan)

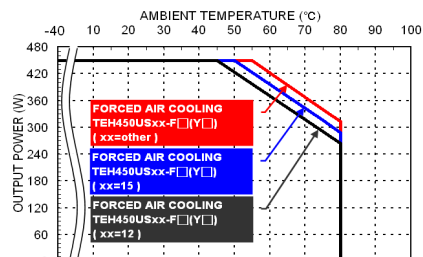

Derating Curve vs. Ambient Temperature  
Vin=115VAC and Forced air cooling (Internal Fan)

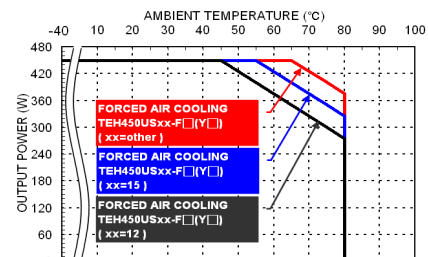

Derating Curve vs. Ambient Temperature  
Vin=230VAC and Forced air cooling (Internal Fan)

## CHARACTERISTIC CURVE (CONTINUED)

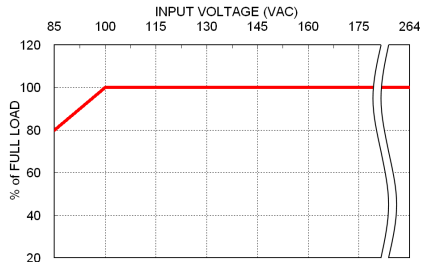

Derating Curve vs. Input Voltage  
TAH450

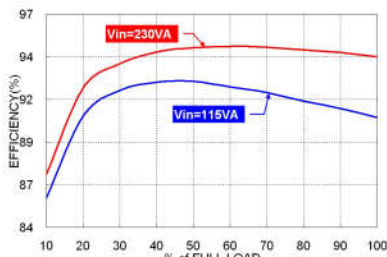

Efficiency vs. Output Load  
TAH450US24 with Forced air cooling

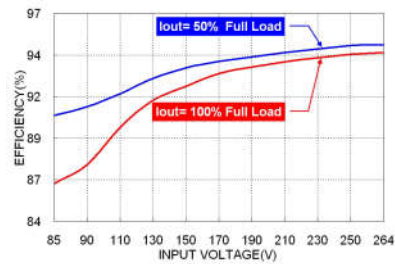

Efficiency vs. Input Voltage  
TAH450US24 with Forced air cooling

## OUTPUT SENSING

Output sensing function can be applied via connecting wires on CON3. Initially, Pin 7 and Pin 8 are shorted by a jumper set as default, shown as Fig. 1.

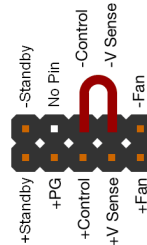
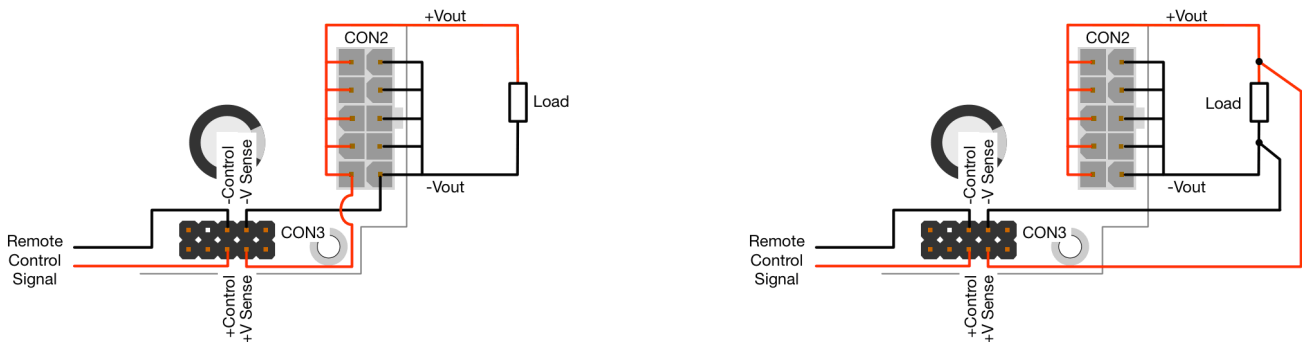

Fig. 1 Default connection

But if remote control function is to be used, the jumper on Pin 7 and Pin 8 should be removed. Since sense pins should not be left open for module stability, please follow the connections as below (Fig. 2).



(a) Sense pins connect to corresponding polarity of Vout pin

(b) Sense pins connect to corresponding polarity terminal of load.

Fig. 2 Recommended output sensing connections

### MECHANICAL DRAWING

#### TAH450USXX (-Y)

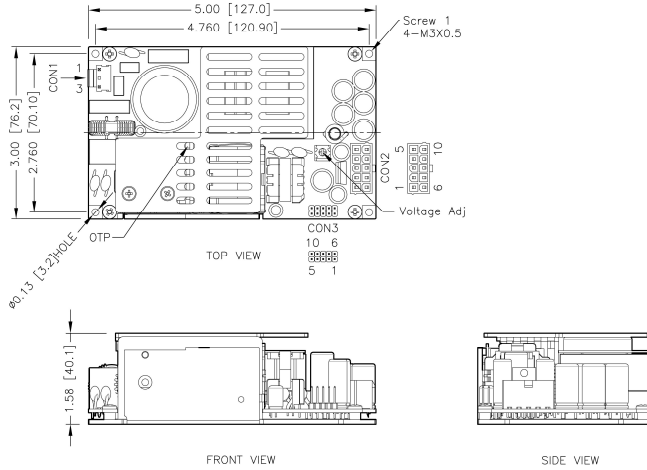

\*Either one of four screw holes can be considered as PE connection for CLASS I application.

1. All dimensions in inch [mm]
2. Tolerance : x.xx±0.02 [x.x±0.5]  
x.xxx±0.01 [x.xx±0.25]
3. Screw 1 locked torque : MAX 5.2Kgf-cm/0.51N.m

#### CONNECTORS CONNECTIONS

##### CON1 – Input Connector

Pin 1	Line
Pin 3	Neutral

Mates with  
Molex housing : **09-50-8031**  
Molex crimp terminals : **2478,6838,45570**

##### CON2 – Output Connector

Pin 1,2,3,4,5	+Vout
Pin 6,7,8,9,10	-Vout

Mates with  
Molex housing : **39-01-2105**  
Molex crimp terminals : **5556,45750**

##### CON3 – Aux Connector

Pin 1	+Fan	Pin 6	-Fan (GND)
Pin 2	+V Sense	Pin 7	-V Sense
Pin 3	+Control	Pin 8	-Control (GND)
Pin 4	+PG	Pin 9	No Pin
Pin 5	+Standby	Pin10	-Standby (GND)

Mates with  
Molex housing : **90143-0008**  
Molex crimp terminals : **90119**

#### TEH450USXX (-Y)

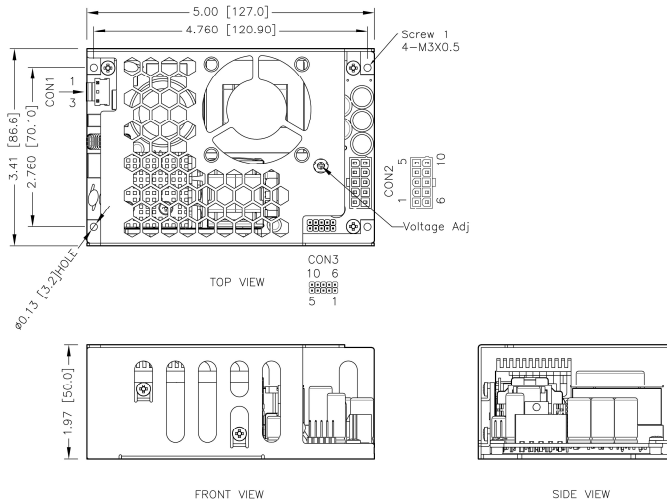

\*Either one of four screw holes can be considered as PE connection for CLASS I application.

1. All dimensions in inch [mm]
2. Tolerance : x.xx±0.02 [x.x±0.5]  
x.xxx±0.01 [x.xx±0.25]
3. Screw 1 locked torque : MAX 5.2Kgf-cm/0.51N.m

#### CONNECTORS CONNECTIONS

##### CON1 – Input Connector

Pin 1	Line
Pin 3	Neutral

Mates with  
Molex housing : **09-50-8031**  
Molex crimp terminals : **2478,6838,45570**

##### CON2 – Output Connector

Pin 1,2,3,4,5	+Vout
Pin 6,7,8,9,10	-Vout

Mates with  
Molex housing : **39-01-2105**  
Molex crimp terminals : **5556,45750**

##### CON3 – Aux Connector

Pin 1	+Fan	Pin 6	-Fan (GND)
Pin 2	+V Sense	Pin 7	-V Sense
Pin 3	+Control	Pin 8	-Control (GND)
Pin 4	+PG	Pin 9	No Pin
Pin 5	+Standby	Pin10	-Standby (GND)

Mates with  
Molex housing : **90143-0008**  
Molex crimp terminals : **90119**

### MECHANICAL DRAWING (CONTINUED)

**TEH450USXX-F1 (Y1)** FAN dimension: 50x50x10mm Air flow: 11.4 CFM  
The fan's life is shorter than power supply and has only 2 years warranty.

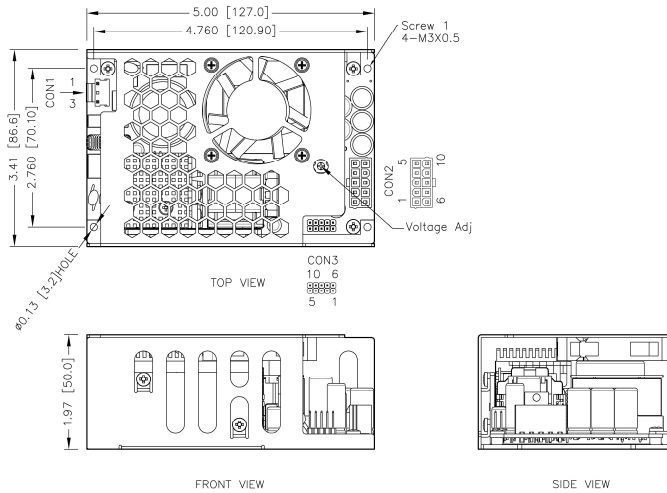

\*Either one of four screw holes can be considered as PE connection for CLASS I application.

1. All dimensions in inch [mm]
2. Tolerance : x.xx±0.02 [x.x±0.5]  
x.xxx±0.01 [x.xx±0.25]
3. Screw 1 locked torque : MAX 5.2Kgf-cm/0.51N.m

### CONNECTORS CONNECTIONS

#### CON1 – Input Connector

Pin 1	Line
Pin 3	Neutral

Mates with  
Molex housing : **09-50-8031**  
Molex crimp terminals : **2478,6838,45570**

#### CON2 – Output Connector

Pin 1,2,3,4,5	+Vout
Pin 6,7,8,9,10	-Vout

Mates with  
Molex housing : **39-01-2105**  
Molex crimp terminals : **5556,45750**

#### CON3 – Aux Connector

Pin 1	+Fan	Pin 6	-Fan (GND)
Pin 2	+V Sense	Pin 7	-V Sense
Pin 3	+Control	Pin 8	-Control (GND)
Pin 4	+PG	Pin 9	No Pin
Pin 5	+Standby	Pin 10	-Standby (GND)

Mates with  
Molex housing : **90143-0008**  
Molex crimp terminals : **90119**

**TEH450USXX-F2 (Y2)** FAN dimension: 40x40x10mm Air flow: 9.5 CFM  
The fan's life is shorter than power supply and has only 2 years warranty.

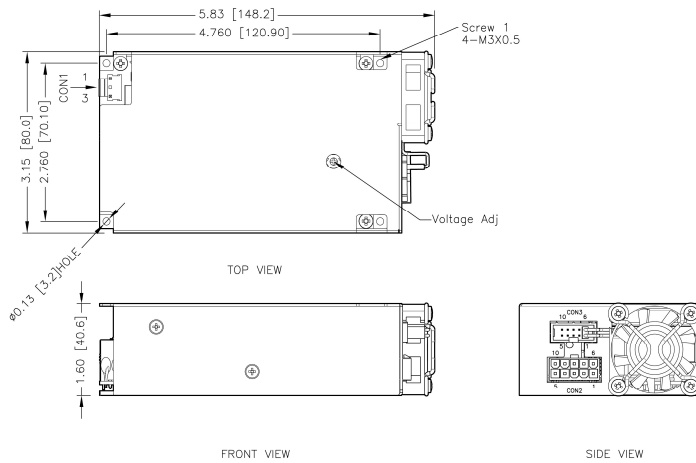

\*Either one of four screw holes can be considered as PE connection for CLASS I application.

1. All dimensions in inch [mm]
2. Tolerance : x.xx±0.02 [x.x±0.5]  
x.xxx±0.01 [x.xx±0.25]
3. Screw 1 locked torque : MAX 5.2Kgf-cm/0.51N.m

### CONNECTORS CONNECTIONS

#### CON1 – Input Connector

Pin 1	Line
Pin 3	Neutral

Mates with  
Molex housing : **09-50-8031**  
Molex crimp terminals : **2478,6838,45570**

#### CON2 – Output Connector

Pin 1,2,3,4,5	-Vout
Pin 6,7,8,9,10	+Vout

Mates with  
Molex housing : **39-01-2105**  
Molex crimp terminals : **5556,45750**

#### CON3 – Aux Connector

Pin 1	+Fan	Pin 6	-Fan (GND)
Pin 2	+V Sense	Pin 7	-V Sense
Pin 3	+Control	Pin 8	-Control (GND)
Pin 4	+PG	Pin 9	No Pin
Pin 5	+Standby	Pin 10	-Standby (GND)

Mates with  
Molex housing : **90143-0008**  
Molex crimp terminals : **90119**

## OPTIONAL PARTS

7N-0265-F :

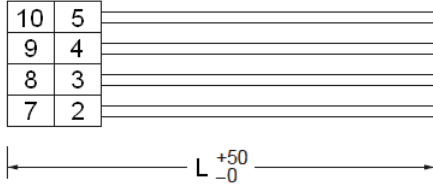

CON3 housing

Pin 2	+V Sense	gray	26AWG
Pin 3	+Control	orange	26AWG
Pin 4	+PG	blue	26AWG
Pin 5	+Standby	red	22AWG
Pin 7	-V Sense	green	26AWG
Pin 8	-Control (GND)	brown	26AWG
Pin 9	No wire	---	---
Pin10	-Standby (GND)	black	22AWG

Length (L) : 500mm typical

7N-0266-F :

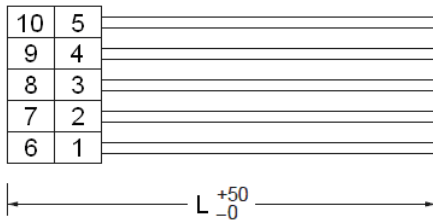

CON3 housing

Pin 1	+Fan	yellow	26AWG
Pin 2	+V Sense	gray	26AWG
Pin 3	+Control	orange	26AWG
Pin 4	+PG	blue	26AWG
Pin 5	+Standby	red	22AWG
Pin 6	-Fan (GND)	brown	26AWG
Pin 7	-V Sense	green	26AWG
Pin 8	-Control (GND)	brown	26AWG
Pin 9	No wire	---	---
Pin10	-Standby (GND)	black	22AWG

Length (L) : 500mm typical