

DRM40 Series Instruction Manual

BEFORE USING THE PRODUCT

Be sure to read this instruction manual thoroughly before using this product. Pay attention to all cautions and warnings before using this product. Incorrect usage may lead to an electrical shock, damage to the unit or a fire hazard.

DANGER

Never use this product in locations where flammable gas or ignitable substances are present.

DANGER

Ne jamais utiliser ce produit en présence de substances inflammables ou explosives.

INSTALLATION WARNING

- When installing, ensure that work is done in accordance with the instruction manual. Improper installation may lead to electric shock and fire.
- Installation shall be done by service personnel with necessary and appropriate technical training and experience. There is a risk of electric shock and fire.
- Do not cover the product with cloth paper or etc. Do not place anything flammable around it as this may cause damage, electric shock or fire.

WARNING ON USE

- Do not touch this product or its internal components while circuit in operation, or shortly after shutdown. You may receive a burn.
- While this product is operating, keep your hands and face away from it as you may be injured by an unexpected situation.
- There are cases where high residual voltage remains inside the product. Therefore, do not touch even if they are not in operation as you may get injured due to high voltage and high temperature. You may also get electric shock or burn.
- Do not make unauthorized changes to this product nor remove the cover as you may get an electric shock or may damage the product. We will not be held responsible after the product has been modified, changed or disassembled.
- Do not use this product under unusual condition such as emission of smoke or abnormal smell and sound etc. Please stop using it immediately and turn off the product. It may lead to fire and electric shock. In such cases, please contact us. Do not attempt to repair, as it is dangerous for the user.
- Do not operate and store these products in environments where condensation occurs due to moisture and humidity. It may lead to fire or electric shock.
- Do not drop or apply shock to this product. It may cause failure. Do not operate these products when mechanical stress is applied.

PRECAUTIONS D'USAGE

- Ne pas toucher ce produit ou l'un de ses composants internes pendant qu'il est sous tension, ou peu après la mise hors tension. Vous pourriez vous brûler.
- Ne pas modifier ce produit sans autorisation ni retirer son capot, vous pourriez recevoir une décharge électrique ou endommager le produit. Nous ne saurions être tenus responsables après que le produit ait été modifié, changé ou démonté.
- Ne pas utiliser ce produit dans des conditions anormales comme la présence de fumées ou d'odeurs inhabituelles ou de bruits suspects etc. Merci d'arrêter l'utilisation immédiatement et d'éteindre le produit. Il pourrait se produire un feu ou un choc électrique. Dans de tels cas, merci de nous contacter. Ne pas essayer de réparer le produit, c'est dangereux pour l'utilisateur.
- Ne pas utiliser ou stocker le produit dans un environnement exposé à la condensation ou à l'humidité. Cela peut provoquer un feu ou un choc électrique.

CAUTION ON MOUNTING

- Follow connections to input/output terminals indicated in the instruction manual before switching on.
- Input and output wires are to be short and thick as possible.
- Do not use this product in special environment with strong electromagnetic field, corrosive gas or conductive substances and direct sunlight, or places where product is exposed to water or rain.
- Mount this product in accordance to the instruction manual and ensure it is well ventilated.
- Please turn off the input source when connecting input and output of the product.
- When installing in environment where conductive foreign material, dust or liquid may be present, please prevent any foreign material into the product by installing filter so as to avoid product's failure or malfunction.

 **CAUTION ON USE**

- Product individual notes are shown in the instruction manual. If there is any difference with common notes, individual notes shall have priority.
- Input voltage, Output current, Output power, ambient temperature and ambient humidity should be kept within specifications, otherwise the product will be damaged, or cause electric shock or fire.
- For products without built-in protection circuit (element, fuse, etc.), insert fuse at the input to prevent smoke, fire during abnormal operation. As for products with built-in protection circuit, depending on usage conditions, built-in protection circuit may not work. It is recommended to provide a separate protection circuit.
- This product is made for general purpose electronic equipment use and is not designed for applications requiring high safety (such as extremely high reliability and safety requirements. Even though high reliability and safety are not required, this product should not be used directly for applications that have serious risk for life and physical safety). Take sufficient consideration in fail-safe design (such as providing protective circuit or protective device inside the system).
- When used in environments with strong electromagnetic field, there is possibility of product malfunction.
- When used in environment with corrosive gas (hydrogen sulfide, sulfur dioxide, etc.), there is possibility that it may cause failure to the product.
- When used in environments where there is conductive foreign matter or dust, there is possibility of product failure or malfunction.
- Provide countermeasure for prevention of lightning surge voltage as there is a risk of damage due to abnormal voltage.
- Connect together the frame ground terminal of the product and the ground terminal of the equipment for safety and noise reduction. If these ground is not connected together, there is a risk of electric shock.
- Take care not to apply external abnormal voltage to the output. Especially, applying reverse voltage or overvoltage more than the rated voltage to the output as it may cause failure, electric shock or fire.
- Depending on product failure mode, there is possibility of hazardous voltage occurrence at the output terminal. Therefore, the output of this product must be protected in the end use equipment to maintain SELV.
- This product contains a printed circuit board utilizing surface mounted devices. PCB stress such as bending, twisting, etc., could cause damage. Please handle with care.

NOTE

- When disposing product, follow disposal laws of each municipality.
- Published EMI (CE, RE) or immunity is the result when measured in our standard measurement conditions and may not satisfy specification when mounted and wired inside end-user equipment. Use the product after sufficient evaluation is done at the actual end-user equipment.
- When exporting our products, apply the necessary permissions as required by rules and regulations of Foreign Exchange and Foreign Trade Control Act.
- Catalogue or contents of the instruction manual may be changed without a prior notice. Refer to latest catalogue or instruction manual.
- Reproduction or reprinting the instruction manual or its portion is not allowed without our permission.

PRECAUTIONS DE MONTAGE ET D'UTILISATION

- Respecter les connexions des borniers d'entrée/sortie décrites dans le manuel utilisateur avant de mettre sous tension.
- Ne pas utiliser ce produit dans un environnement exposé à un fort champ électromagnétique, à des substances corrosives ou conductrices, à la lumière directe du soleil ou à la pluie et l'humidité.
- En cas d'installation dans un environnement où des particules conductrices, de la poussière ou des liquides peuvent être présents, merci d'installer des filtres afin de prévenir toute intrusion de corps étrangers à l'intérieur du produit et d'éviter pannes et dysfonctionnements.
- Ce produit est destiné aux équipements électroniques à usage general et il n'est pas conçu pour des applications à hauts risques (telles que les applications de sécurité ou de grande fiabilité. Même si une grande fiabilité ou une grande sécurité ne sont pas requises, ce produit ne doit pas être utilisé directement dans des applications présentant des risques sérieux pour la vie ou l'intégrité physique). Le principe de défaillance sécuritaire doit être appliqué à la conception (tels que l'installation de circuits ou de composants de protection).
- Connecter la masse du châssis et la borne de terre de l'équipement pour la sécurité et la réduction de bruit. Si cette connexion n'est pas faite, il existe un risque de choc électrique.
- En fonction du type de défaillance, il existe une possibilité de présence d'une tension dangereuse sur les bornes de sortie. Ainsi, la sortie de ce produit doit être protégée dans l'équipement final pour conserver la TBTS.

STORAGE METHOD AND STORAGE PERIOD

- Store in original package
- Prevent excessive vibration, impact and external force from being applied during storage.
- Store in an area out of direct sunlight
- Temperature and humidity should be within range of product specification (with no condensation)
- Storage period should be up to two years from receiving.

CE MARKING

CE Marking, when applied to a product covered by this handbook indicates compliance with the following:

- Low Voltage Directive in that it is complied with EN60950-1 & EN62368-1.
- EMC Directive
- Restriction of the use of certain Hazardous Substances Directive (RoHS)

1. Model Name Identification Method

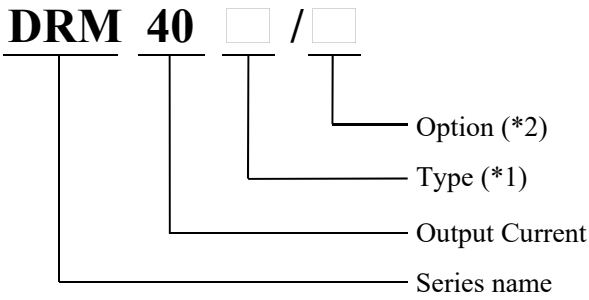

(*1) Version

Blank: Standard type

B: Basic (without Balance OK /DC OK LED and relay)

(*2) Type of input and output connectors

Blank: Standard type

/E: 4 Pins Spring Type

2. Terminal Explanation

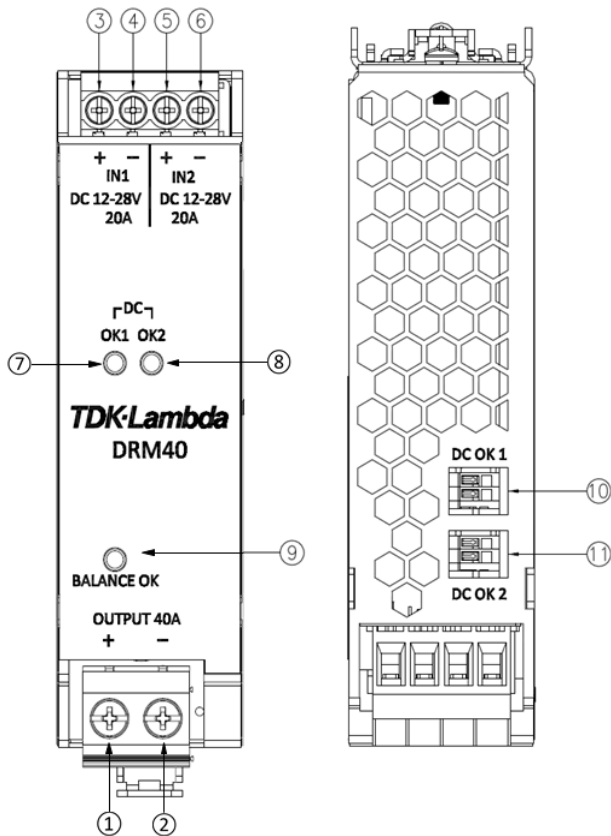

① +Vout : + Output terminal

② -Vout : - Output terminal

③ +Vin1 : + Input terminal 1

④ -Vin1 : - Input terminal 1

⑤ +Vin2 : + Input terminal 2

⑥ -Vin2 : - Input terminal 2

⑦ DC OK1 : Green LED lights up when Input Voltage 1 is within specification

⑧ DC OK2 : Green LED lights up when Input Voltage 2 is within specification

⑨ BALANCE OK : Green LED lights up when both input voltage level is close to each other. (IN1 and IN2)

⑩ DC OK1 : Relay (Photo Mosfet)

⑪ DC OK2 : Relay (Photo Mosfet)

NOTE : ⑦ to ⑪ are excluded in the basic version

i.e. DRM40B/_

3. Terminal Connecting Method

Pay attention to the input wiring. If it is connected to wrong terminal, the product will be damaged.

- Input must be off when making connections.
- Use wires as short and thick as possible
- When connecting or removing input and output wire, do not apply excessive stress to the unit.

4. Explanations of Functions and Precautions

4-1. Input Voltage Range

Input voltage range is 10 ~ 30VDC. Input voltage which is out of specified range or reversed, may cause unit to damage. For cases where conformance to various safety specification (UL, CSA, EN) are required, input voltage range will be 12 ~ 28VDC.

NOTE : DC input source is SELV or Limited Voltage supplied by external isolated power supply(reinforced or double insulation).

4-2. Output Voltage

The output voltage will be typically 200mV (at 40A) lower than the input voltage. Do not apply reverse voltage on the output terminals as it may cause unit to damage.

4-3. Signal Output

To check the presence or absence of voltage at the input terminal of the unit , DC OK LED and relay signal is available. Indicators and signal performance may vary depending on input line condition.

Signal Output	VDC 10V ≤ Vin ≤ 30V	VDC 10V ≥ Vin ≥ 30V
DC OK1 (LED : Green)	ON	OFF
DC OK2 (LED : Green)	ON	OFF
DC OK1 (Photo Relay)	Close	Open
DC OK2 (Photo Relay)	Close	Open

Balance OK LED indicator is also available to check the input voltage difference of two power supplies. In case that the input voltage difference is small, LED lights up and the output current of the connected power supplies tends to be balanced.

Signal Output	VDC ΔVin ≤ 50mV	VDC ΔVin > 50mV
BALANCE OK (LED : Green)	ON	OFF

NOTE : ΔVin is voltage difference between IN1 & IN2.

In case that the input voltage difference is not small enough, LED is turned off.

NOTES:

- (1) Adjust two power supplies output voltage as close as possible for better current balance performance. Recommended

- (2) output voltage difference for two power supply is less than 20mV. Performance may vary depending on the upstream power supply unit.
- (3) Redundant operation is still possible even Balance OK LED is off. Although balanced power supply units expect longer life than unbalanced condition.
- (4) Same input cables of length and size from two power supplies are recommended in order for a better current balance performance.

4-4. DC OK

In normal operation relay DC OK is close when the input voltage is greater than or equal 10V. When the input voltage is greater than 30V relay DC OK is open. Signal DC OK relay is rated at 30V/ 0.5A.

4-5. Input and Output Current

Maximum input current is 2 x 20A.

Maximum output current is 40A.

NOTE : Current limit response is dependent on input source.

4-6. Peak Input and Output Current

The DRM40 can deliver 150% peak current for 4 seconds aiding the startup of capacitive loads. Downstream circuit breakers can be used to protect the product during this condition. The operating conditions for peak output current are as followed:

- Duty cycle of peak current, $D \leq 35\%$
- \leq rated output power and RMS current
- Reduce peak current according to output derating curve for higher ambient temperature.
- Peak output current and its duration are defined as followed :

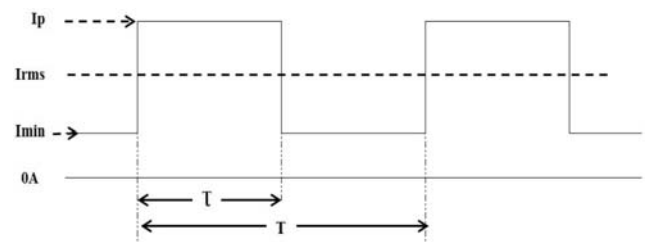

I_p : Peak output current (A)

I_{rms} : RMS output current (Arms)

I_{min} : Minimum output current (A)

τ : Peak current pulse width (sec)

T : Period (sec)

Input voltage range (Vin) : 10 - 30VDC

Continuous peak output time (τ) : Within 4 sec

Peak output current (I_p) : Within the rated peak output current (60A)

Rms output current (I_{rms}) : Within the rated rms output current (40Arms)

Duty, $D = \tau / T \times 100\%$ $\leq 35\%$

$I_{rms} = [I_p^2 \times D + I_{min}^2 \times (1-D)]^{1/2} \leq 40Arms$

4-7. Redundancy Operation

The product can be used for redundancy operation as an alternative to the diode. In redundant operation, it is possible to continue supplying the power by another power supply when one power supply fails. For redundant and parallel operation use same model for upstream power supplies.

Fig. A Dual Input (2x20A)

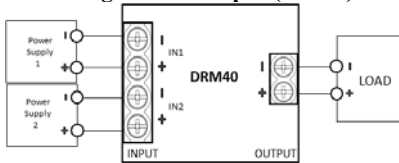
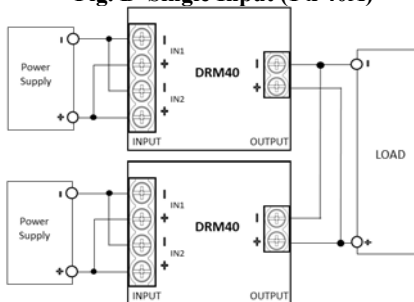

Fig. B Single Input (1 x 40A)



NOTE : For single input operation connect +IN1 to +IN2 and -IN1 to -IN2.

4-8. Parallel Operation

Parallel connection to obtain total output current up to 40A when the number of input source (DC power supply) is two pieces. The example of the parallel operation as below.

Method A

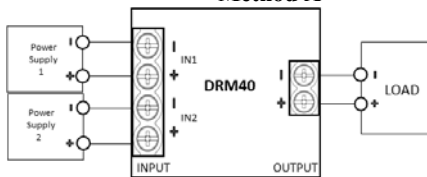

- Use within the specification. Do not exceed max. input/output current of 40A/60A (peak). Use current limited source, e. g., DRF/DRB series or suitable fuse.
- Adjust the output voltage of each power supply to be the same.
- When one of power supply fails, the output current of other power supply is increased. Shut down the power supply as soon as possible to prevent damage on the product.
- Use external fuse for safety, to protect the product in the case of short circuit or overload.

4-9. Operation for Battery Application

DRM40 series can be used for battery charging application as below :

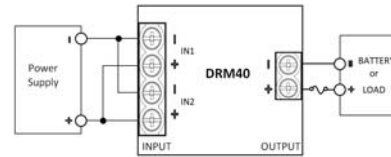

CAUTION :

(a) Care must be observed when wiring to the battery load. There is a risk of battery short-circuit through the charging power supply and the product itself. This may damage the product and the power supply.

(b) The product has no internal fuse.

When the polarity of the product and battery are wrongly connected, there is a risk of short circuit current flow from battery to the product. Do not exceed rated current. If there is a risk to exceed rated current please put fuse or breaker between the product and the battery. It is recommended to select time-lag fuse to be connected to +V line when -V is grounded.

4-10. Caution on Short Circuit of Output Terminal

When the output of the product is short-circuited, there is a possibility that the power supply⁽¹⁾ voltage on the input side drops and the current increases. In this case, internal components of the product may damage due to excessive heat generation. You must stop using the product immediately. Shut down the power supply as soon as possible as it may cause damage on the product.

- Ensure upstream source current does not exceed 60A in all cases. Check the short-circuit current of the power sources and if the power source can deliver more than this, use an appropriate fuse on the output. Recommended fuse: 0299050 (50A) from Littelfuse or with equivalent Time-Current characteristics curve.

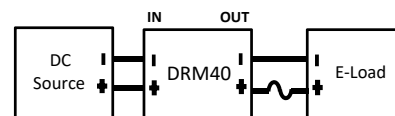

Time-Current Characteristic Curves 0299050_

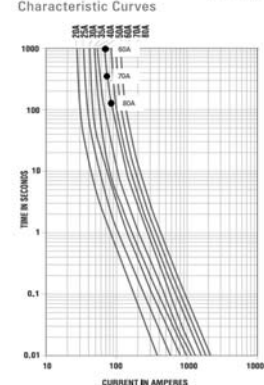

4-11. Isolation Test

Isolation resistance between input, output terminal and FG (chassis) shall be more than 100MΩ at 500VDC. For safety operation, voltage setting of DC isolation tester must be done before the test. Ensure that the unit is fully discharged after the test.

- Input, Output - FG : 500VDC , 100MΩ or more

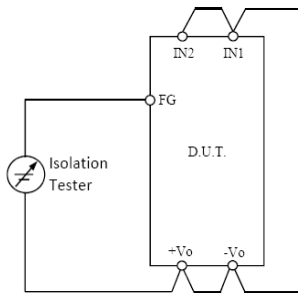

4-12. Withstand Voltage

This product is designed to withstand 707VDC between input, output and FG (chassis) for 1 minute. When performing withstand voltage, set current limit of the withstand voltage tester to 20mA. The applied voltage must be gradually increased from zero to the required level and then gradually decreased for shut down. Connect input and output as follows.

- Input, Output - FG : 707VDC , 1min (20mA)

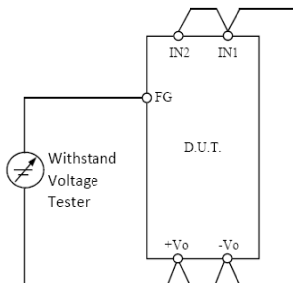

5. Mounting Directions

Recommended standard mounting method is vertical with the input connector at the top. Do not exceed the load derating. See section 6.

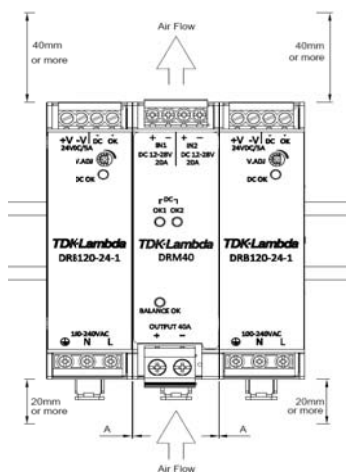

Minimum Installation clearances:

40mm on top and 20mm on the bottom. Clearance between the redundancy module and the power supplies can be reduced to zero under the following conditions:

- Power supplies are from TDK dinrail series (i.e DRF/DRB).
- Redundancy module is placed between the two power supplies.
- 1+1 redundancy operation with maximum $I_{out}=20A$.
- Output voltage is set to the same level on both upstream power supplies.

5.1. Power supply mounting on DIN RAIL (TS35 or equivalent)

Make sure input and output wire are disconnected before mounting power supply onto rail

- Tilt the unit slightly backwards, fit the unit over the top hat rail.
- Slide it downward until it hits the stop.
- Press against the bottom front side for locking. Shake the unit slightly to check the locking action.

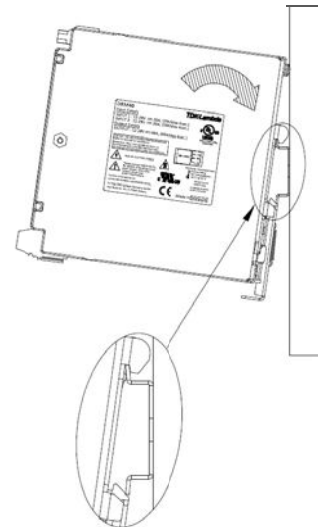

- In order to tighten the unit mounting, the Din rail stopper attached on both sides of the unit is recommended.

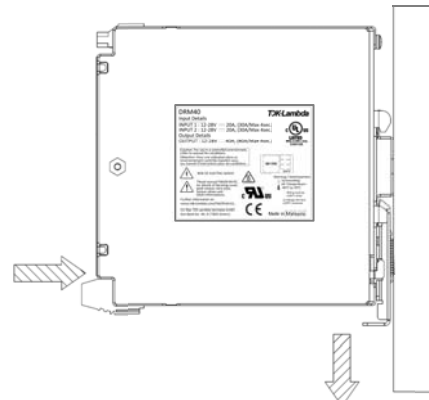

5.2. Power supply removal from DIN RAIL

- (1) Turn off power and disconnect your system from the supply network. Pull the Latch on the rear lower edge of the unit downwards and gently lift lower front edge of the unit (tipping upwards) and remove it.

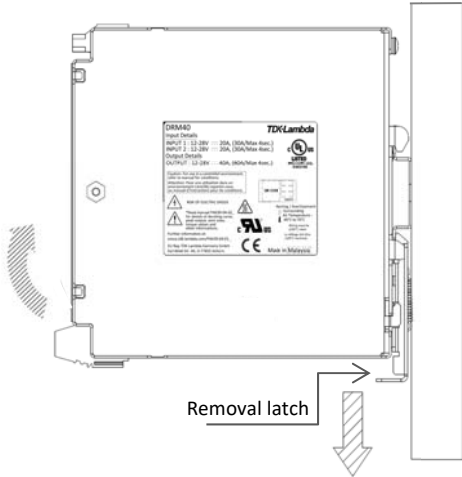

6. Mounting Method – DRM40 series

6.1. Mounting Method

The standard mounting is mounting A. Mounting B and C are also possible. Do not mount the product in any other directions. Use within the range specified in section 6 for derating.

**MOUNTING A
(Standard Mounting)**

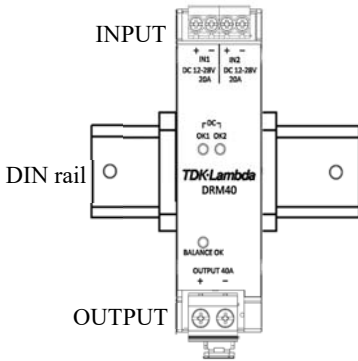

MOUNTING B

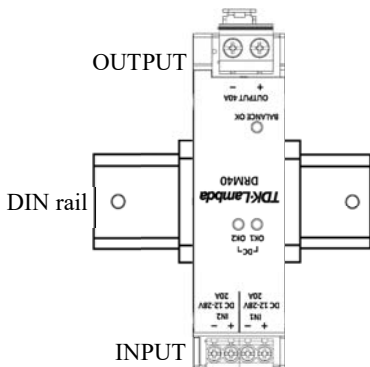

MOUNTING C

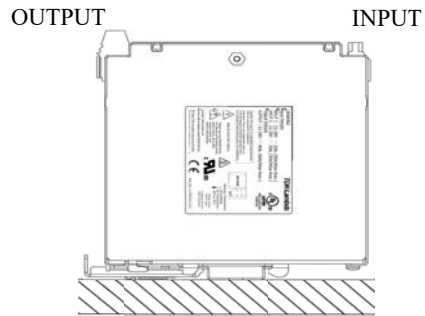

6.2. Output Derating (Input/Output Current)

OUTPUT DERATING vs AMBIENT CURVE

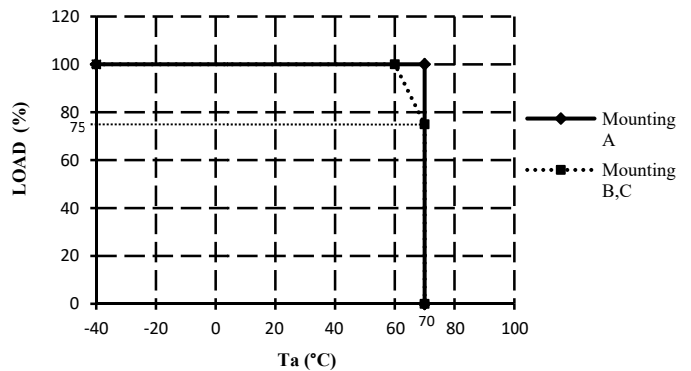

6.3. Altitude Derating

ALTITUDE DERATING CURVE

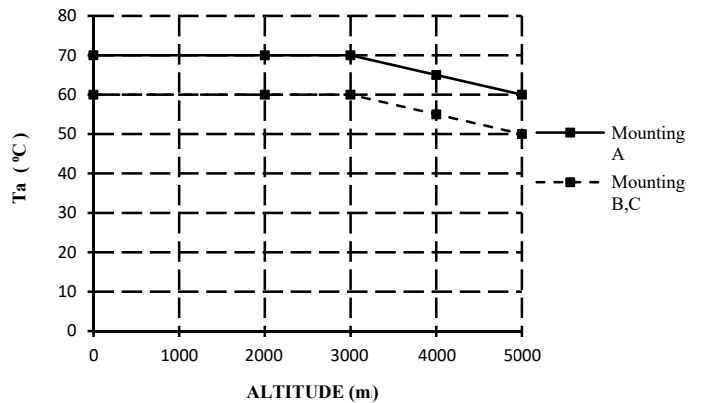

7. Wiring Method

- The output load and input wire shall be separated and twisted to improve noise susceptibility.
- Use all lines as thick and short as possible to make lower impedance.

7.1 EMC

The DRM40 complies with the provisions of the EMC directive and meets the following standards:

Emissions: EN55032 Class B, CISPR32-B,

EN61204-3 Class A

Immunity: EN61000-4-2, -3, -4, -5, -6, -8

8. DRM40 series UL508 Listed Condition

Wiring / Torque Recommendation

Model Type	Connector	Wiring(AWG)	Max Torque
DRM40	INPUT (IN1, IN2)	10 - 24	10.3kgf.cm(9lbf.in)
DRM40B	OUTPUT (+, -)	6 - 26	23.6kgf.cm(20.5lbf.in)
	SIGNAL (DC OK1, DC OK2)	16 - 24	N.A.
DRM40/E DRM40B/E	INPUT (IN1, IN2)	10 - 24	N.A.
	OUTPUT (+, -)		
	SIGNAL (DC OK1, DC OK2)	16 - 24	

NOTE : According to EN/UL60950-1 multi-strand flexible cables connected to the input require ferrule.

- 1) Use minimum 105°C wire and copper conductor only.
- 2) For use in a Pollution degree 2 environment only
- 3) These products are considered for use where maximum surrounding air temperature does not exceed 70°C. When installing refer to section 6 for derating.
- 4) Indoor use only.
- 5) The maximum permissible current depends on the cross section of the connected cables and the ambient temperature. Refer below table for details:

RECOMMENDED WIRE SIZE (AWG)		AMBIENT TEMPERATURE	
		60°C	70°C
Output (DRM40 & DRM40B)	6 AWG	1 x 40A	1 x 40A
	8 AWG	1 x 40A	1 x 36A
Input	10 AWG	2 x 20A	2 x 20A
	12 AWG	2 x 20A	2 x 18A

NOTE : For model with 4 pin OUTPUT wire gauge is same as input.

Product marking:

TDK-Lambda

TDK-Lambda Singapore Pte. Ltd.

(Sales, Services and R&D)

1008 Toa Payoh North #06-01/08, #07-01/03

Singapore 318996

Telephone: +65 62517211

Facsimile: +65 62509171

WEBSITE: www.tdk-lambda.com.sg

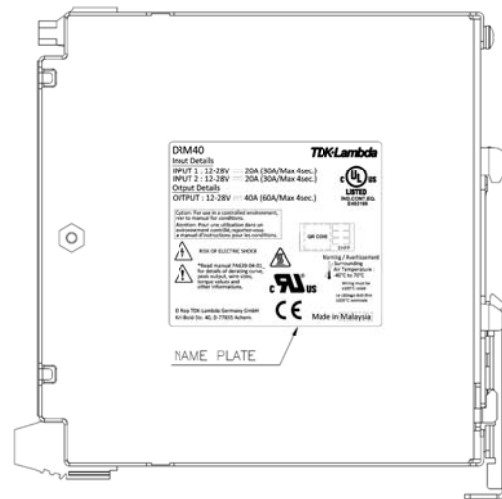

NOTE : Name plate's contents shown in this instruction manual is for reference only.

9. Before concluding that the unit is at fault

Before concluding that the unit is at fault, make the following checks.

- Check if the input/output voltage & current is within specification.
- Check if the connection of input and output is correct.
- Check if the wire size is not too small.
- Check if the output of the upstream power supplies is on the same voltage level.

10. Returns

Please contact your local sales office or visit our website to arrange return of any faulty product.