

fleXPower Series



- Industrial / IT & Medical Approvals
- Configurable For Fast Time To Market
- Semi F47 Compliant
- Flexible Series & Parallel Capability
- -20 °C Operation
- Extra Power Available At High Line
- 6 Power Platforms
- Fully Featured Signal Set
- Isolated Signals with Reverse logic Option
- Meets EN60601-1-2 & EN61204-3 For EMC
- FMEA Available
- Optional Fan Speed Control

The fleXPower series is a range of modular power supplies which can be configured into a bespoke solution for quick delivery of samples, prototypes and low volume production.

The range consists of 8 power platforms ranging from 400W to 2400W and 14 modules ranging from 3.3V at 66W to 60V at 750W. The modules can be placed in series or in parallel to give a single output at the chassis rating. Modules of unlike power can be paralleled and will current share within 10%.

Signals are floating and allow for configuration as active low or active high and include AC OK, global DC OK, module DC OK and current monitor. There is a global inhibit signal which can alternatively be configured as a global enable.

fleXPower consists of a chassis of the required power level in which there are 10 slots in versions rated up to 700W, 12 slots for the 900W version, 14 slots for the 1000W version and 16 slots in the 1500 W version. An extra 200W of power is available from X4, X5, X7, X9 & X10 chassis at high line and an extra 1000 W is available from the X15 chassis at high line.

fleXPower chassis can be specified as industrial or medical types. Industrial versions have EN60950 and UL60950 approvals and also meet the requirements of EN61010. Medical versions are approved to EN60601-1 and UL60601-1 and also meet the EMC requirements specified in UL60601-1-2 2nd Edition.

Helios Power Solutions is XP Distributor

Australia: sales@heliosps.com.au - New Zealand: sales@heliosps.co.nz - Asia & Middle East: sales@heliosps.asia

Input Characteristics - X7 Models

Characteristic	Format	Voltage	Frequency	Minimum	Typical	Maximum	Units	Notes & Conditions
Input Voltage AC				85		264	VAC	
Input Voltage DC				120		370	VDC	
Input Frequency				47		63	Hz	400 Hz operation. See note 1.
Power Factor	Single	115 V	50 Hz		1.00			See Harmonics Graph 1
		115 V	400 Hz		0.97			See Harmonics Graph 3
		230 V	50 Hz		0.98			See Harmonics Graph 2
		230 V	400 Hz		0.72			See Harmonics Graph 4
	DD	115 V	50 Hz		0.99			See Harmonics Graph 5
		115 V	400 Hz		0.97			See Harmonics Graph 7
		230 V	50 Hz		0.98			See Harmonics Graph 6
		230 V	400 Hz		0.71			See Harmonics Graph 8
Input Current, No Load	Single	115 V			0.211		A	
		230 V			0.278		A	
	DD	115 V			0.422		A	
		230 V			0.556		A	
Input Current, Full Load	Single	115 V			7.57	9.33	A	5.33 A for X4, 6.67 A for X5
		230 V			3.77	4.67	A	2.67 A for X4, 3.33 A for X5
	DD	115 V			15.14	18.66	A	10.66 A for X4DD, 13.33 A for X5DD
		230 V			7.54	5.34	A	5.33 A for X4DD, 6.66 A for X5DD
Inrush Current	Single	115 V			6.6	20	A	
		230 V			11.0	20	A	264 VAC
	DD	115 V			13.2	40	A	
		230 V			22.0	40	A	264 VAC
Leakage Current	Single	115 V			205		μA	50 Hz
		230 V			370	1500	μA	50 Hz, 200 μA max. for XM
	DD	115 V			410		μA	50 Hz
		230 V			740	3000	μA	50 Hz, 400 μA max. for XM
Input Protection	T12A / 250V internal fuse in line and neutral							

1. Class A harmonic current levels, leakage current levels are exceeded.

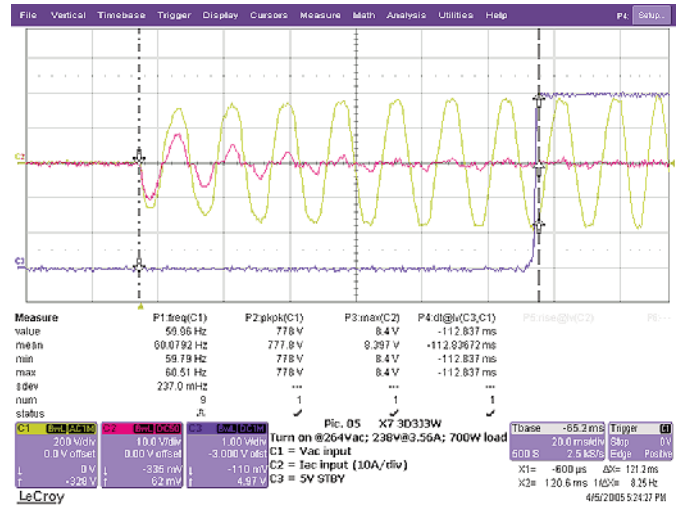
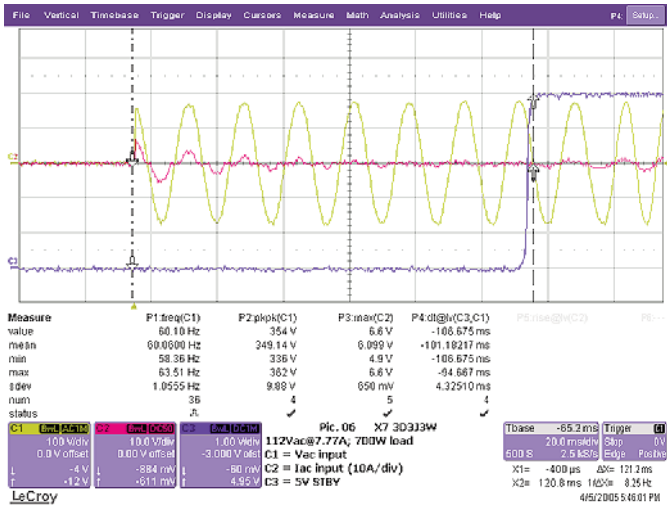

Input Characteristics - X9 Models

Characteristic	Format	Voltage	Frequency	Minimum	Typical	Maximum	Units	Notes & Conditions
Input Voltage AC				85		264	VAC	
Input Voltage DC				120		370	VDC	
Input Frequency				47		63	Hz	400 Hz operation. See note 1.
Power Factor	Single	115 V	50 Hz		1.00			See Harmonics Graph 9
		115 V	400 Hz		0.97			See Harmonics Graph 11
		230 V	50 Hz		0.98			See Harmonics Graph 10
		230 V	400 Hz		0.73			See Harmonics Graph 12
	DD	115 V	50 Hz		0.99			See Harmonics Graph 13
		115 V	400 Hz		0.97			See Harmonics Graph 15
		230 V	400 Hz		0.72			See Harmonics Graph 16
Input Current, No Load	Single	115 V			0.265		A	
		230 V			0.367		A	
	DD	115 V			0.530		A	
		230 V			0.734		A	
Input Current, Full Load	Single	115 V			9.95	12.00	A	
		230 V			4.89	6.00	A	
	DD	115 V			19.90	24.00	A	
		230 V			9.78	12.00	A	
Inrush Current	Single	115 V			10.0	40	A	See Plot 3
		230 V			14.0	40	A	264 VAC. See Plot 4
	DD	115 V			20.0	80	A	
		230 V			28.0	80	A	264 VAC
Leakage Current	Single	115 V			252		μA	50 Hz
		230 V			512	1500	μA	50 Hz, 200 μA max. for XM
	DD	115 V			504		μA	50 Hz
		230 V			1024	3000	μA	50 Hz, 400 μA max. for XM
Input Protection	T15A / 250V internal fuse in line and neutral							

1. Class A harmonic current levels, leakage current levels are exceeded.

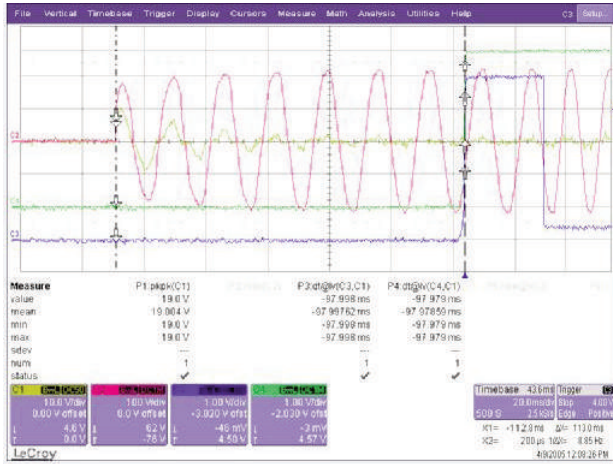

Plot 3. Inrush current for X9 at 115 VAC

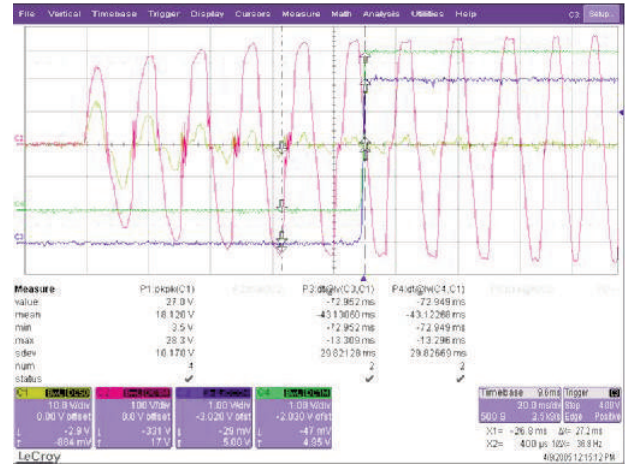

Plot 4. Inrush current for X9 at 230 VAC

Input Characteristics - X10 Models

Characteristic	Format	Voltage	Frequency	Minimum	Typical	Maximum	Units	Notes & Conditions
Input Voltage AC				85		264	VAC	
Input Voltage DC				120		370	VDC	
Input Frequency				47		63	Hz	400 Hz operation. See note 1.
Power Factor	Single	115 V	50 Hz		1.00			See Harmonics Graph 17
		115 V	400 Hz		0.97			See Harmonics Graph 19
		230 V	50 Hz		0.98			See Harmonics Graph 18
		230 V	400 Hz		0.73			See Harmonics Graph 20
	DD	115 V	50 Hz		0.99			See Harmonics Graph 21
		115 V	400 Hz		0.97			See Harmonics Graph 23
		230 V	50 Hz		0.98			See Harmonics Graph 22
		230 V	400 Hz		0.72		See Harmonics Graph 24	
Input Current, No Load	Single	115 V			0.265		A	
		230 V			0.367		A	
	DD	115 V			0.530		A	
		230 V			0.734		A	
Input Current, Full Load	Single	115 V			9.95	13.30	A	
		230 V			4.89	6.67	A	
	DD	115 V			19.90	26.6	A	
		230 V			9.78	13.3	A	
Inrush Current	Single	115 V			10.0	40	A	See Plot 5
		230 V			14.0	40	A	264 VAC. See Plot 6
	DD	115 V			20.0	80	A	
		230 V			28.0	80	A	264 VAC
Leakage Current	Single	115 V			142		μ A	50 Hz
		230 V			281	1500	μ A	50 Hz, 200 μ A max. for XM
	DD	115 V			284		μ A	50 Hz
		230 V			562	3000	μ A	50 Hz, 400 μ A max. for XM
Input Protection	T20A / 250V internal fuse in line and neutral							

1. Class A harmonic current levels, leakage current levels are exceeded.

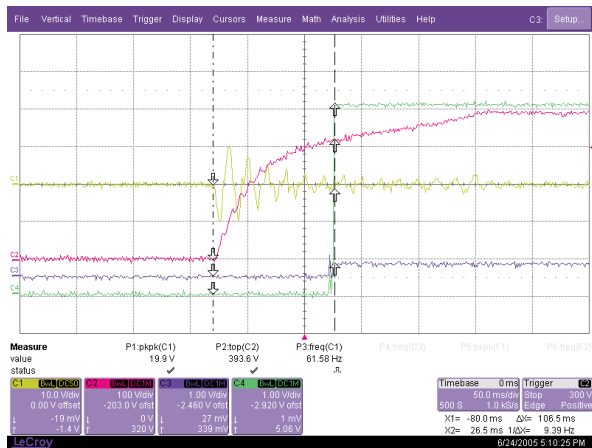

Plot 5. Inrush current for X10 at 115 VAC

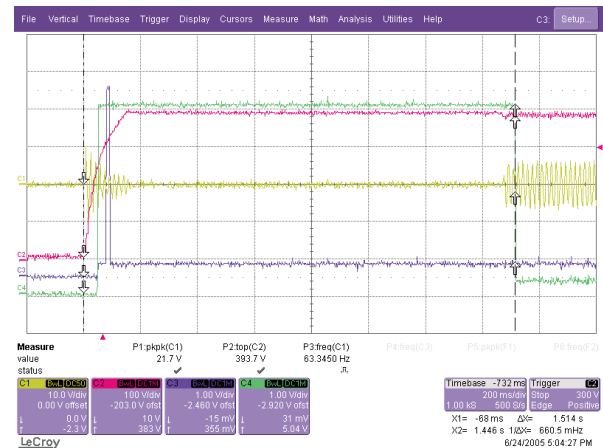

Plot 6. Inrush current for X10 at 230 VAC

Input Characteristics - X15 Models

Characteristic	Voltage	Frequency	Minimum	Typical	Maximum	Units	Notes & Conditions
Input Voltage AC			85		264	VAC	
Input Voltage DC			120		370	VDC	
Input Frequency			47		63	Hz	400 Hz operation. See note 1.
Power Factor	120 V	60 Hz		0.997			See Harmonics Graph 27
	230 V	60 Hz		0.980			See Harmonics Graph 28
Input Current, No Load	115 V			0.750		A	
	230 V			0.700		A	
Input Current, Full Load	115 V			16.31		A	
	230 V			12.89		A	
Inrush Current	115 V			16.50	40	A	See Plot 7
	230 V			28.00	40	A	264 VAC. See Plot 8
Input Protection	T30A / 250V internal fuse in line and neutral						

1. Class A harmonic current levels, leakage current levels are exceeded.

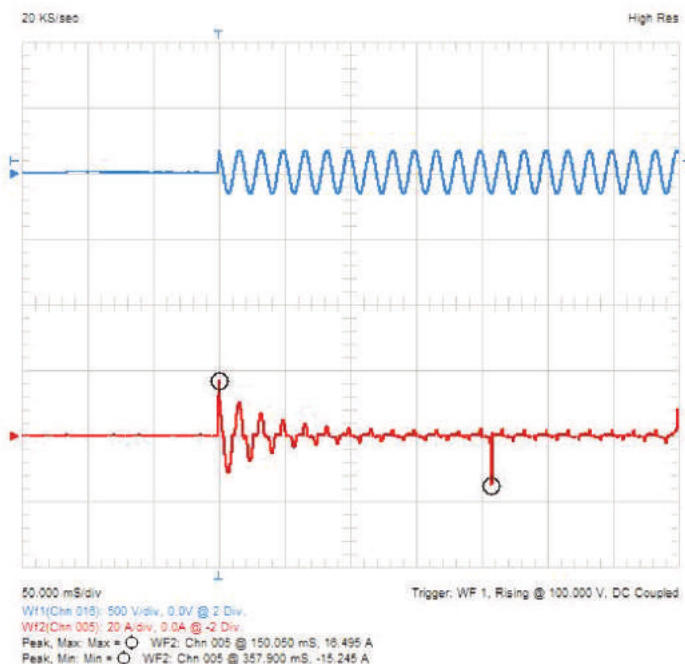

Plot 7. Inrush current for X15 at 115 VAC

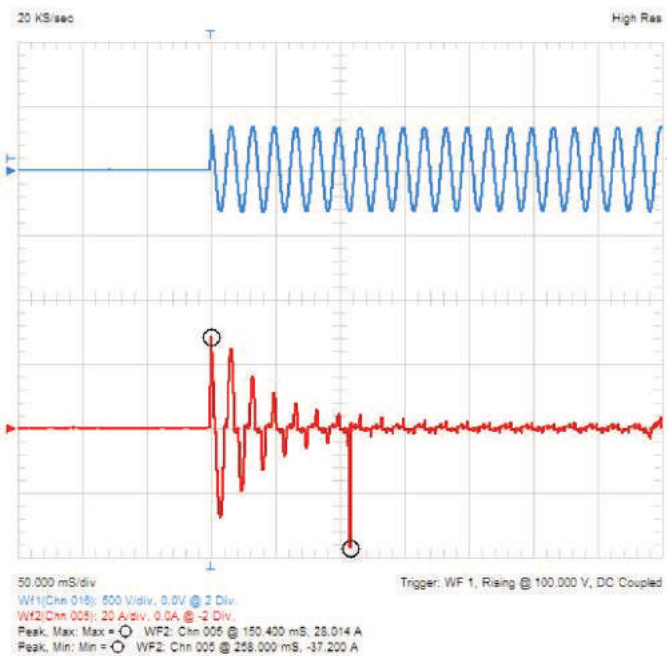

Plot 8. Inrush current for X15 at 230 VAC

Output Characteristics

Characteristic	Minimum	Typical	Maximum	Units	Notes & Conditions
Voltage	2		60	VDC	See modules table
Initial Set Accuracy				0.13%	
Voltage Adjustment	±10			%	±6 min for 3.3 V output
Voltage Programming	±6			%	-6% apply 0 V, +6% apply 5 V to VProg pin
Minimum Load		0		A	No minimum load required for 2, 3 or 4 slot single output modules and 6 x dual output modules. 2 slot 5 x dual output modules require 10% load on V1 to meet specified regulation on V2
Start Up Delay		1.6	2	s	To 90% of nominal output. See Plot 9
Start Up Delay from ROF		3		ms	
Start Up Rise Time		37.5		ms	See Plot 10
Hold Up Time X7	20	33.5		ms	For X7 with full load.
Hold Up Time X7 high line	20	24.35		ms	For X7 with 900 W load, high line.
Hold Up Time X9	20	37.5		ms	For X9 with full load.
Hold Up Time X9 high line	20	30.7		ms	For X9 with 1100 W load, high line.
Hold Up Time X4	20	67.0		ms	For X4 with full load.
Hold Up Time X5	20	51.0		ms	For X5 with full load.
Hold Up Time X10	20	45.2		ms	For X10 with full load.
Hold Up Time X10 high line	20	44.2		ms	For X10 with 1200 W load
Hold Up Time X15	16	44.8		ms	For X15 with full load.
Hold Up Time X15 high line	16	22.7		ms	For X15 with 2500 W load
Line Regulation		0.01	0.1	%	
Load Regulation			1	%	
Transient Response		0.7	±2	%	50-100% load change, recovery time 300 µs
Ripple & Noise		0.1	1.0	%	20 MHz BW, 150 MHz BW typical 0.2% 48 V output. 6E module has 1.5% max on V1 and V2, 6N module has 1.5% max on V1 and 3% max on V2
Over Voltage Protection	115	125	130	%	140% max for 6E and 6N modules.
Overload Protection	110		140	%	2x, 3x and 4x modules
	110		150		1x modules
	110		150		V1 and 110-200% on V2 of 5x modules
	110		200		V1 and V2 of 6x modules
Overtemperature Protection		115		°C	Measured Internally, Auto Resetting
Short Circuit Protection					Continuous auto-resetting
Temperature Coefficient			0.03	% / °C	
Parallel Connections	Via single wire parallel. Dissimilar powers will share within 10%.				
Housekeeping Voltage	5 V/1 A from each chassis				

Plot 9. Start Up Delay

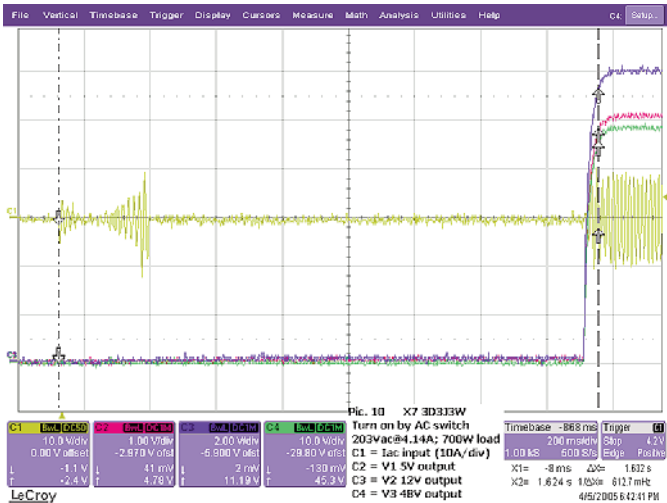

Plot 10. Start Up Rise Time

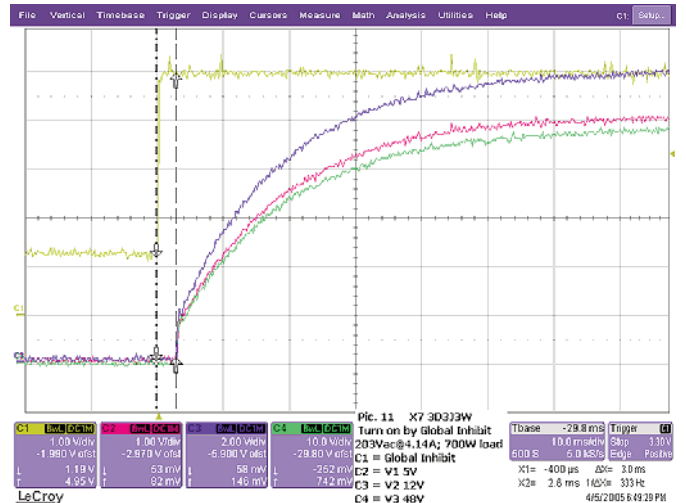

Isolation

Characteristic	Minimum	Typical	Maximum	Units	Notes & Conditions
Input to Output	4000			VAC	
Input to Ground	1500			VAC	
Output to Ground	250			VDC	

Environmental

Characteristic	Minimum	Typical	Maximum	Units	Notes & Conditions
Operating Temperature	-20		+70	°C	Full power to +50 °C, 50% power at +70 °C, -20 °C startup only
Reverse Fan Operating Temperature	-20		+60	°C	Full power to +40 °C, 50% power at +60 °C, -20 °C startup only
Operating Humidity	5		95	% RH	Non-condensing
Storage Temperature	-40		+85	°C	
Operating Altitude			3000m/4000m	m	Medical/ITE
Shock	MIL STD-810 Method 516.4 Procedure 1, 30G, half sine, 6 axes				
Vibration	MIL STD-810 Method 514.4 Procedure 1, 1 G rms, 5-500 Hz, 3 axes				

General

Characteristic	Minimum	Typical	Maximum	Units	Notes & Conditions
PFC Switching Frequency		65		kHz	Housekeeping supply 130 kHz typical
Module Switching Frequency		200		kHz	
Weight X7 Chassis			2.75 (1250)	lbs (g)	
Weight X9 Chassis			3.3 (1500)	lbs (g)	
Weight X10 Chassis			4.0 (1800)	lbs (g)	
Weight X15 Chassis			8.0 (3636)	lbs (g)	
Weight 2X Module			0.48 (218)	lbs (g)	
Weight 3X Module			0.74 (335)	lbs (g)	
Weight 4X Module			0.95 (431)	lbs (g)	
Power Density X4			3.2	W / in ³	
Power Density X5			4.0	W / in ³	
Power Density X7			5.6	W / in ³	
Power Density X9			6.0	W / in ³	
Power Density X10, X15			5.7	W / in ³	
Efficiency		83.5%			See graphs page 20

Reliability

	Designation	25 °C	40 °C	Units	Notes & Conditions
2 Slot Modules	2D	1,211,340	735,321	Hours	MTBF calculation assumptions: 1) All SMD resistors are considered 10K. 2) Quality level is Lower(hermetically) for transistor and diode by default unless higher quality is mentioned. 3) Non-ER' is used in quality level of capacitor and resistor during the calculation. 4) Commercial' is used in quality level of IC and Relay during the calculation. 5) Special correction factor as 0.01 was used in Q1 and Q2 of the X7,X9 due to the improper module of the software. 6) Fans are not considered during the calculation.
	2J	1,221,690	736,597	Hours	
	2P	1,158,754	697,325	Hours	
	2R	895,129	532,978	Hours	
	2W	1,160,350	699,271	Hours	
3 Slot Modules	5X	748588	521,751	Hours	
	3C	1,160,350	707,221	Hours	
	3D	1,196,651	728,751	Hours	
	3J	1,321,184	740,414	Hours	
	3L	1,207,620	730,995	Hours	
	3P	1,205,278	729,020	Hours	
	3Q	1,210,351	731,751	Hours	
	3R	569,600	382,000	Hours	
4 Slot Modules	3U	1,198,520	725,096	Hours	
	3W	1,192,223	720,847	Hours	
Chassis	All modules	460,029	327,176	Hours	
	X4	843,674	507,459	Hours	
	X5	843,674	507,459	Hours	
	X7	599,009	320,296	Hours	
	X9	559,615	336,507	Hours	
	X10	527,132	316,918	Hours	
	X15	181,127	126,133	Hours	

To calculate the MTBF of your configuration, select the individual MTBF for each modules and use the calculation below to derive total MTBF.

$$\frac{1}{\text{MTBF TOTAL}} = \frac{1}{\text{MTBF1}} + \frac{1}{\text{MTBF2}} + \dots + \frac{1}{\text{MTBFn}}$$

Safety Approvals

Safety Agency	Safety Standard	Category
CB Report	UL IEC60950-1:2005 Ed 2	Information Technology
UL	UL File #E139109-A62-UL UL60950-1 (2007), CSA 22.2 No.60950-1-07 Ed 2	Information Technology
TUV	EN60950-1:2006	Information Technology
CE	LVD	

Safety Agency	Safety Standard	Category
CB Report	IEC60601-1 Ed 3 Including Risk Management	Medical (XM Models)
UL	UL File # E146893, ANSI/AAMI ES 60601-1:2005 & CSA C22.2 No. 60601-1:08	Medical (XM Models)
TUV	EN60601-1:2006	Medical (XM Models)

Means of Protection		Category
Primary to Secondary	2 x MOPP (Means of Patient Protection)	IEC60601-1 Ed 3
Primary to Earth	1 x MOPP (Means of Patient Protection)	

Equipment Protection Class	Safety Standard	Notes & Conditions
Class I	IEC60950-1:2005 Ed 2 & IEC60601-1 Ed 3	See safety agency conditions of acceptability for details

Electromagnetic Compatibility - Immunity

Phenomenon	Standard	Test Level	Criteria	Notes & Conditions
ESD	EN61000-4-2	4	A	
EFT	EN61000-4-4	3	A	
Radiated	EN61000-4-3	10 V/m	A	
Surges	EN61000-4-5	3	A	
Conducted	EN61000-4-6	10 V/m	A	
Dips and Interruptions	EN61000-4-11	70% Ut	A	For 10 ms, 100% load
		40% Ut	B	For 100 ms, 100% load
		0% Ut	B	For 5000 ms, 100% load
Dips and Interruptions*	EN61000-4-11 (Medical)	70% Ut	A	For 500 ms, Medical, 100% load
		40% Ut	A	For 100 ms, Medical, 60% load
		0% Ut	A	For 10 ms, Medical, 100% load
		0% Ut	B	For 5000 ms, Medical, 100% load

Complies with EN60601-1-2 for medical equipment, and EN61204-3 for IT equipment. *(EN60601-1-2 available as option)

Electromagnetic Compatibility - Emissions

Phenomenon	Standard	Test Level	Criteria	Notes & Conditions
Conducted (X models)	EN55022	Class B		
Conducted (XM models)	EN55011	Class A		
Radiated	EN55022	Class A		
Harmonic Currents	EN61000-3-2	Class A		
Voltage Fluctuations	EN61000-3-3			

Complies with EN60601-1-2 for medical equipment, and EN61204-3 for IT equipment.

Conducted Emissions

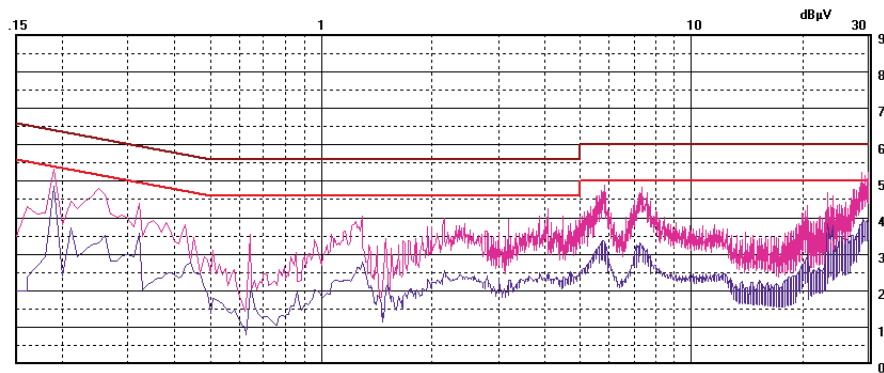

Limit #1: 55022bav Limit #2: 55022bap Detector: Peak, Average
flexpower x7-3l3q2d half load v1 1i65 v2 4/4 v3 r11

Peak and average emissions for X7-3L3Q2D configuration against Class B limits

Configuration - Model Number Construction

The fleXPower range allows for simple configuration of a custom modular power supply with up to twenty outputs. The chassis consists of either ten, twelve or fourteen slots, and modules are either two, three or four slots wide. Please refer to next page for specific X15 configuration information.

CHASSIS

OUTPUT MODULES 1-5 (1-6: 900 W chassis/ 1-7: 1000 W chassis)

OPTIONS

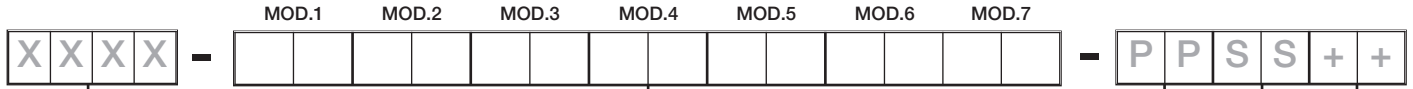

Model	Sector	Vinput				Slots
		115 V		230 V		
		Pnom	Ppk*	Pnom	Ppk*	
X4	Industrial	400 W	800 W	600 W	1200 W	10
XM4	Medical	400 W	800 W	600 W	1200 W	10
X5	Industrial	500 W	800 W	700 W	1200 W	10
XM5	Medical	500 W	800 W	700 W	1200 W	10
X7	Industrial	700 W	800 W	900 W	1200 W	10
XM7	Medical	700 W	800 W	900 W	1200 W	10
X9	Industrial	900 W	1100 W	1100 W	1500 W	12
XM9	Medical	900 W	1100 W	1100 W	1500 W	12
X10	Industrial	1000 W	1300 W	1200 W	1600 W	14
XM10	Medical	1000 W	1300 W	1200 W	1600 W	14
X15	Industrial	1500 W	1500 W	2500 W	2500 W	20
XM15	Medical	1500 W	1500 W	2500 W	2500 W	20

Note: Peak power available for 10 seconds with 35% duty cycle.

Step 1

To configure your fleXPower unit, select the required output power and application type. fleXPower chassis are available in five industrial and five medical power formats, detailed above.

Step 2

FleXPower can accommodate up to seven modules, resulting in an extensive range of output combinations. However, as all modules are designed to fit across either 2, 3 or 4 slots in the chassis, configuration is very simple. Select the appropriate modules for your output requirements, ensuring that all modules will fit in the chassis. X4, X5 and X7 chassis have the capacity to accept up to two 4 series modules. X9 and X10 chassis will accept up to three 4 series modules, and X15 chassis will accept up to 4 series modules, max of 2 each per bay. First, insert 4 series modules, ordered lowest voltage to highest. Next in order, insert 3 series modules, ordered by the lowest voltage for same module width. Follow with 2 series single output, lowest voltage to highest voltage, then 5 series multi-output, ordered alphabetically a-z. Then 1 series, single output modules, lowest voltage to highest

Step 3

Add any required options. These are grouped into three types; parallel options, series options and other options. The standard signal set for each chassis includes Global Inhibit, Global DC OK and Global AC OK, each having logic 0 operation. Optionally a logic 1 operating version of each is available along with reverse air flow. Also available is a fan speed control card option, which is available separately or combined with previously listed options.

Example

X7-3C3L2C-002316

Leave blank if no options are required

- X7 - 700 W industrial chassis, module slots available.
- 3C - 3.3 V @ 60.0 A. Three slot width module.
- 3L - 15.0 V @ 20.0 A. Three slot width module.
- 2C - 3.3 V @ 40.0 A. Two slot width module.
- 00 - No parallel option.
- 23 - Modules 2 and 3 in series to give 18.3 V @ 20.0 A.
- 16 - Fan speed control card.

Single Output - Module Voltage/Current Rating						
Voltage	Current	Ipk	Power	Ppk	Slots	Code
3.3 V	20.0 A	n/a	66 W	n/a	2	1C
3.3 V	40.0 A	n/a	132 W	n/a	2	2C
3.3 V	60.0 A	n/a	198 W	n/a	3	3C
5.0 V	20.0 A	n/a	100 W	n/a	2	1D
5.0 V	40.0 A	n/a	200 W	n/a	2	2D
5.0 V	60.0 A	n/a	300 W	n/a	3	3D
12.0 V	8.50 A	n/a	102 W	n/a	2	1J
12.0 V	17.0 A	n/a	204 W	n/a	2	2J
12.0 V	25.0 A	n/a	300 W	n/a	3	3J
12.0 V	62.5 A	n/a	750 W	n/a	4	4J
15.0 V	7.00 A	n/a	105 W	n/a	2	1L
15.0 V	14.0 A	n/a	210 W	n/a	2	2L
15.0 V	20.0 A	n/a	300 W	n/a	3	3L
15.0 V	50.0 A	n/a	750 W	n/a	4	4L
24.0 V	5.00 A	n/a	120 W	n/a	2	1P
24.0 V	10.5 A	n/a	252 W	n/a	2	2P
24.0 V	17.0 A	n/a	408 W	n/a	3	3P
24.0 V	31.5 A	n/a	750 W	n/a	4	4P
24.0 V	5.00 A	10.0 A	120 W	240 W	2	1R ⁽¹⁾
24.0 V	10.5 A	21.0 A	252 W	504 W	2	2R ⁽¹⁾
24.0 V	17.0 A	34.0 A	408 W	816 W	3	3R ⁽¹⁾
28.0 V	4.50 A	n/a	126 W	n/a	2	1Q
28.0 V	9.00 A	n/a	252 W	n/a	2	2Q
28.0 V	14.0 A	n/a	392 W	n/a	3	3Q
28.0 V	26.8 A	n/a	750 W	n/a	4	4Q
36.0 V	3.50 A	n/a	126 W	n/a	2	1U
36.0 V	7.00 A	n/a	252 W	n/a	2	2U
36.0 V	11.0 A	n/a	396 W	n/a	3	3U
36.0 V	21.0 A	n/a	750 W	n/a	4	4U
42.0 V	9.05 A	n/a	400 W	n/a	3	3V
48.0 V	2.50 A	n/a	120 W	n/a	2	1W
48.0 V	5.20 A	n/a	249 W	n/a	2	2W
48.0 V	8.50 A	n/a	408 W	n/a	3	3W
48.0 V	15.7 A	n/a	750 W	n/a	4	4W
60.0 V	2.00 A	n/a	120 W	n/a	2	1Y
60.0 V	4.20 A	n/a	252 W	n/a	2	2Y
60.0 V	7.00 A	n/a	420 W	n/a	3	3Y
60.0 V	12.5 A	n/a	750 W	n/a	4	4Y

1. Peak power available for 10 seconds with 35% duty cycle, if peak power rating is exceeded output may latch, recycle input to reset.

Dual Output - Module Voltage/Current Rating					
Output 1		Output 2		Slots	Code
Voltage	Current	Voltage	Current		
5.0 V	10.0 A	5.0 V	10.0 A	2	5A
5.0 V	10.0 A	3.3 V	10.0 A	2	5B
12.0 V	10.0 A	12.0 V	8.0 A	2	5D
15.0 V	8.0 A	15.0 V	6.0 A	2	5E
15.0 V	8.0 A	15.0 V	6.0 A	2	6E*
15.0 V	8.0 A	12.0 V	8.0 A	2	5F
12.0 V	10.0 A	5.0 V	10.0 A	2	5G
12.0 V	10.0 A	3.3 V	10.0 A	2	5H
12.0 V	10.0 A	2.0 V	10.0 A	2	5J
15.0 V	10.0 A	5.0 V	10.0 A	2	5K
15.0 V	10.0 A	3.3 V	10.0 A	2	5L
15.0 V	10.0 A	2.0 V	10.0 A	2	5M
24.0 V	6.0 A	5.0 V	10.0 A	2	5N
24.0 V	6.0 A	5.0 V	10.0 A	2	6N*
24.0 V	6.0 A	3.3 V	10.0 A	2	5P
24.0 V	6.0 A	2.0 V	10.0 A	2	5Q

*No minimum load needed on output 1 for regulation

Parallel Option Codes	
Code	Description
00	No parallel required
12	Modules 1 & 2
13	Modules 1 to 3
14	Modules 1 to 4
23	Modules 2 & 3
24	Modules 2 to 4
25	Modules 2 to 5
34	Modules 3 & 4
35	Modules 3 to 5
40	Modules 1 & 2, 3 & 4

Series Option Codes	
Code	Description
00	No series required
12	Modules 1 & 2
13	Modules 1 to 3
23	Modules 2 & 3
24	Modules 2 to 4
40	Modules 1 & 2, 3 & 4

Other Option Codes	
Code	Description
01	Reverse Air
02	Global Enable - Logic 1
03	Option 01 & 02
04	Global DC OK - Logic 1
05	Option 01 & 04
06	Option 02 & 04
07	Option 01, 02 & 04
08	Global AC OK - Logic 1
09	Option 01 & 08
10	Option 02 & 08
11	Option 01, 02 & 08
12	Option 04 & 08
13	Option 01, 04 & 08
14	Option 02, 04 & 08
15	Option 01, 02, 04 & 08
16	Fan Speed Control
17	Option 01 & 16
18	Option 02 & 16
19	Option 04 & 16
20	Option 08 & 16
21	Option 01, 02 & 16
22	Option 01, 04 & 16
23	Option 01, 08 & 16
24	Option 02, 04 & 16
25	Option 02, 08 & 16
26	Option 04, 08 & 16
27	Option 01, 02, 04 & 16
28	Option 01, 02, 08 & 16
29	Option 02, 04, 08 & 16
30	Option 01, 02, 04, 08 & 16

Note: Fancard options 16-30 will occupy 2 slots.

Note: All options also applicable to X15

X15 Configuration Rules

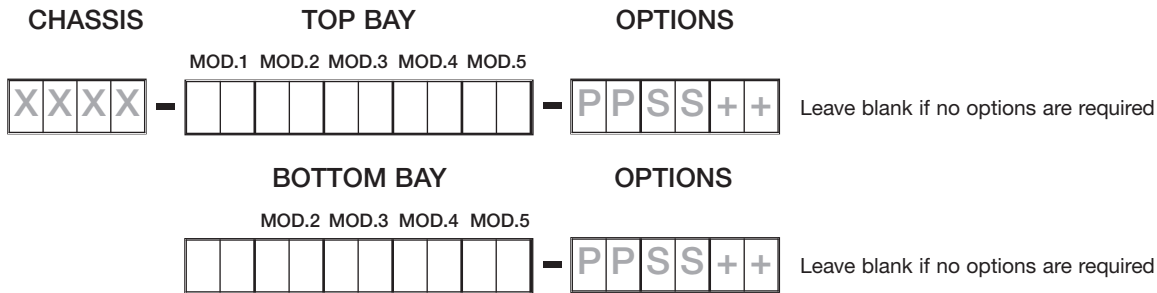

- Configuration for X15 is Chassis - Top Bay - Options
Bottom Bay - Options
- Modules for each bay are configured same as X4, X5, X7, X10.
- Maximum 1250W for each bay, power to be evenly distributed between top and bottom bays.
- Option codes within each bay is the same as X4 to X10.
- Fan control card mounts on bottom bay standard. For other mount location contact sales.
- 1st and 2nd digits = parallel like voltages, including vertical parallel.
- 3rd and 4th digits = series option designation.
- 5th and 6th digits = other option codes. (5th and 6th digits fan card options 16 to 30 is called out for one bay only, either top or bottom).

Vertical Parallel Option Codes	
Code	Description
61	Parallel module 1 to module 1 top and bottom
62	Parallel module 2 to module 2 top and bottom
63	Parallel module 3 to module 3 top and bottom
64	Parallel module 4 to module 4 top and bottom
65	Parallel module 5 to module 5 top and bottom
91	Parallel module 1 to module 1 top and bottom, plus parallel code 12 top bay
92	Parallel module 1 to module 1 top and bottom, plus parallel code 12 top & 12 bottom bay
93	Parallel module 1 to module 1 top and bottom, plus parallel code 13 top & 12 bottom bay
94	Parallel module 2 to module 2 top and bottom, plus parallel code 23 top bay
95	Parallel module 2 to module 2 top and bottom, plus parallel code 23 top & 23 bottom bay
96	Parallel module 2 to module 2 top and bottom, plus parallel code 24 top & 24 bottom bay
97	Parallel module 3 to module 3 top and bottom, plus parallel code 34 top bay
98	Parallel module 3 to module 3 top and bottom, plus parallel code 34 top & 34 bottom bay

Notes

1. All information and options described on the previous page are also valid for x15, including options codes as listed.

Example 2

- 5V @ 160A, 5V @ 40A, 48V @ 5.2A, 12V@ 10A, 2V @ 10A, with fan speed control

X15-3D2D5J-61 3D2D2W-120016

Front End & Top Bay & Options

X15-3D2D5J-61

X15 - 2500 W industrial chassis, 20 module slots configured as 2 bays of 10 slots each.

3D - 5.0V @ 60.0 A. Three slot width module.

2D - 5.0V @ 40.0 A. Two slot width module.

5J - 12V @ 10.0 A., 2V @ 10.0 A. Two slot width dual output module.

61 - Vertical parallel module 1 top bay to module 1 bottom bay

Bottom Bay & Options

3D2D2W-120016

3D - 5.0V @ 60.0 A. Three slot width module

2D - 5.0V @ 40.0 A. Two slot width module

2W - 48V @ 5.2 A. Two slot width module

12 - Parallel modules 1 and 2, bottom bay

00 - No series option

16 - Fan speed control card



fileXPpower

X15-3D2D5J-61/3D2D2W-120016

INPUT J2 LOGIC CONNECTOR		MODULE LOGIC CONNECTOR DUAL OUTPUT		MODULE LOGIC CONNECTOR SINGLE OUTPUT	
1 GL INH-	6 GL ACOK C	1 +SENSE V1	6 +INHIBIT	1 +SENSE V1	6 +INHIBIT
2 GL INH+	7 5V SB	2 -SENSE V1	7 -INHIBIT	2 -SENSE V1	7 -INHIBIT
3 GL DCOK E	8 5V SB RTN	3 NOT USED	8 +DCOK	3 V_PROG	8 +DCOK
4 GL DCOK C	9 INH SUM	4 I_SHARE	9 -DCOK	4 I_SHARE	9 -DCOK
5 GL ACOK E	10 -VCC	5 +SENSE V2	10 -SENSE V2	5 NOT USED	10 NOT USED

5J 12.0V/10.0A 2.0V/10.0A
2D 5.0V/40.0A
3D 5.0V/60.0A
5V / 160A

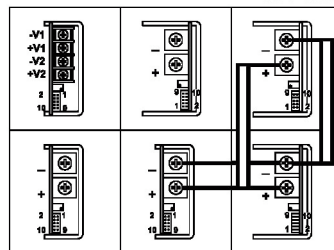

2W 48V/5.2A
2D 5.0V/40.0A
3D 5.0V/60.0A

Signals

Global AC OK/Power Fail

Global AC OK is an open collector signal providing a minimum of 5 ms warning of loss of output regulation. The signal is fully isolated and the collector and emitter must be connected externally.

Maximum sink current 2 mA, maximum voltage 20 V.
On dual output module, DC OK monitors V1 output only.

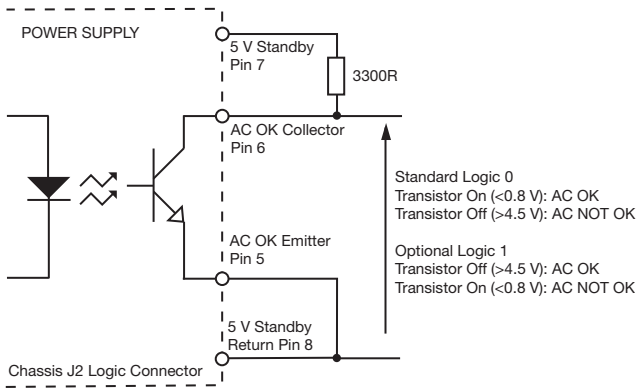

Global DC OK

Global DC OK is an open collector signal providing warning that the output voltage has fallen below 90% of nominal. The signal is fully isolated and the collector and emitter must be connected externally.

Maximum sink current 2 mA, maximum voltage 20 V.
On dual output module, DC OK monitors V1 output only.

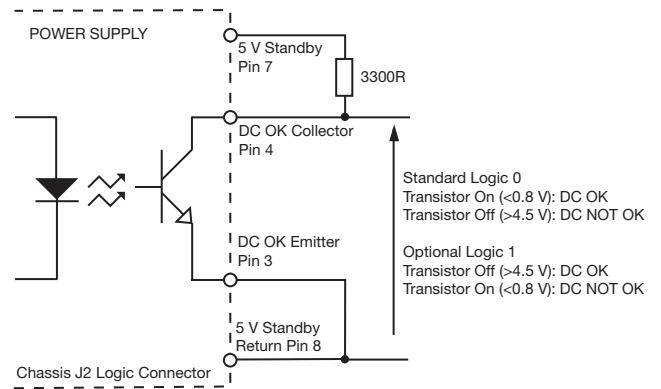

Global Inhibit

Global Inhibit is an isolated control signal which can turn the power supply off by supplying 2 to 5mA into the pin. Global Enable option available, see 'Other Option Codes' table.

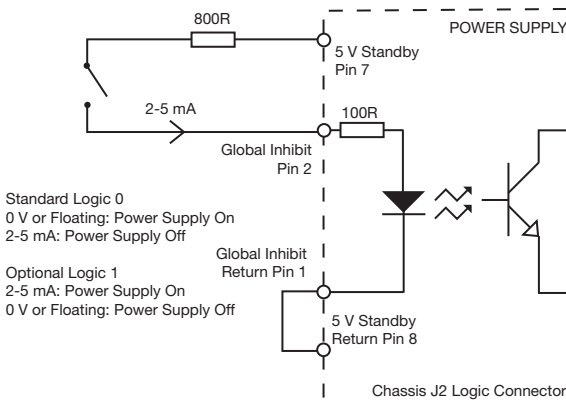

Fan Fail

When fan speed control fitted (option 16).

Open collector signal warns of any fan failure.

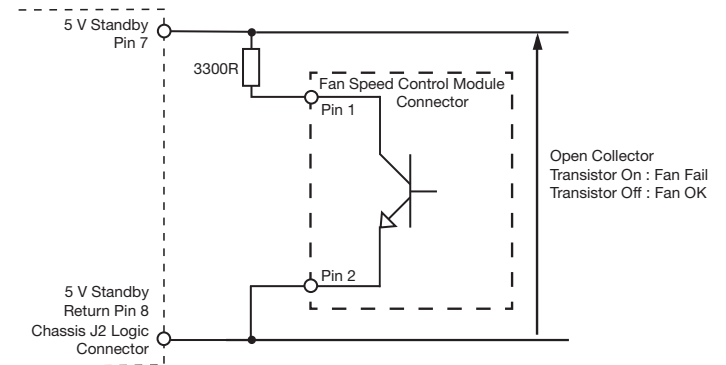

Module DC OK

Module DC OK is a nominal "ON" floating collector and emitter transistor of an optocoupler, which provides a warning of the loss of output regulation on the main output of the module.

Maximum sink current 2 mA, maximum voltage 20 V.

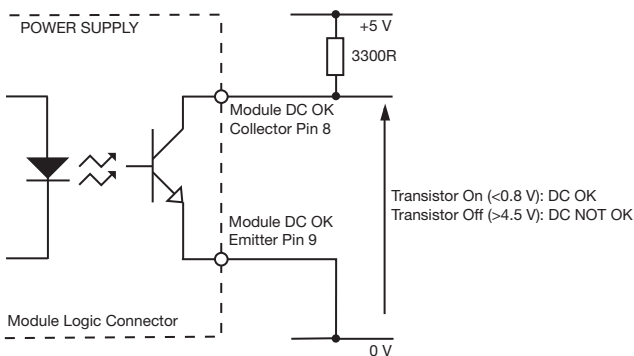

Module Inhibit

Module Inhibit signal is an isolated control signal which can turn the module off by supplying 2 to 5 mA into the pin.

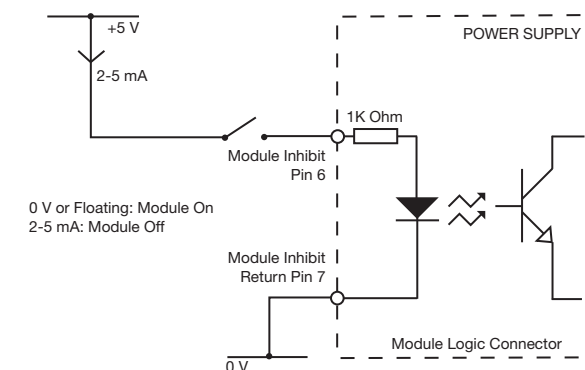

Current Share

Connecting pins 2 and 4 of like voltage modules (4 maximum) within the same chassis or separate chassis will force the current to share between the outputs. Different slot width modules can share.

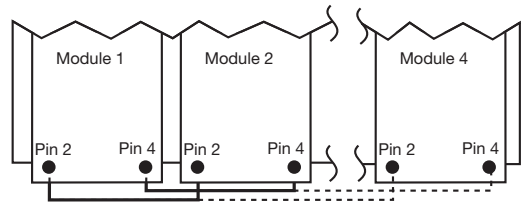

Module Mechanical Details

Single Output

2 Slot Modules

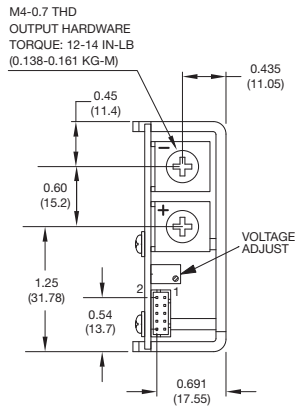

2 Slot Modules (1R/2R Peak)

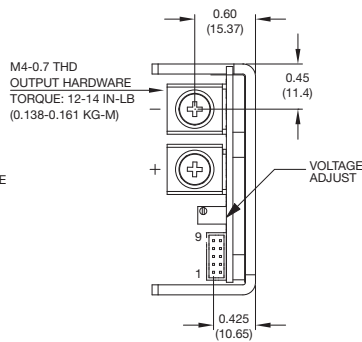

3 Slot Modules (3R Peak)

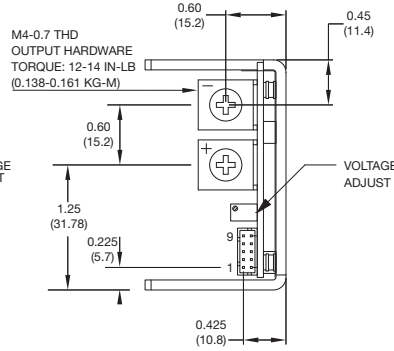

4 Slot Modules

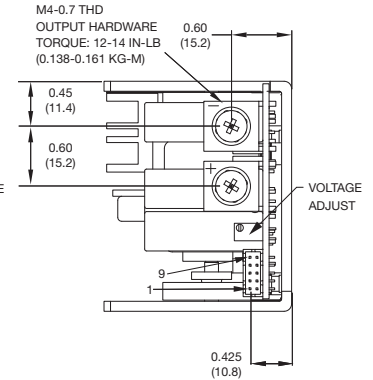

Single Output: Module Logic Connector Pinouts			
Pin	Function	Pin	Function
1	Sense +	6	Inhibit
2	Sense -	7	Module Inhibit Return
3	V Prog	8	DC OK Collector
4	I Share	9	DC OK Emitter
5	Not used	10	Not used

Notes

- All dimensions in inches (mm).
Tolerance: x.xx = ±0.02 (±0.50), x.xxx = ±0.01 (±0.25)
- Weight: 2 / 2R Slot : 0.48 lb (218 g) approx,
3 Slot : 0.74 lb (335 g) approx.
4 Slot : 0.95 lb (431 g) approx.
- Mating plug: JST p/n PHDR-10VS.
- Contact: 26-22 AWG JST p/n SPHD-001T-P0.5.

Dual Output

2 Slot Modules

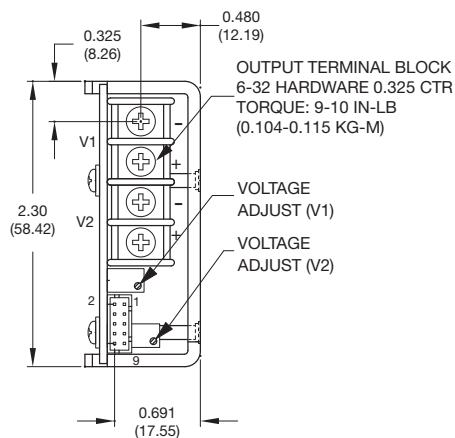

Dual Output: Module Logic Connector Pinouts	
Pin	Function
1	V1 Sense +
2	V1 Sense -
3	Not used
4	Not used
5	V2 Sense +
6	Inhibit
7	Module Inhibit Return
8	DC OK Collector
9	DC OK Emitter
10	V2 Sense -

Notes

- All dimensions in inches (mm).
Tolerance: x.xx = ±0.02 (±0.50), x.xxx = ±0.01 (±0.25)
- Weight: 0.48 lb (218 g) approx.
- Mating plug: JST p/n PHDR-10VS.
- Contact: 26-22 AWG JST p/n SPHD-001T-P0.5.

Fan Speed Control Module

2 Slot Module

Controls speed of fan(s) depending on output load and thermal environment of the power supply. Also provides warning of any fan failure.

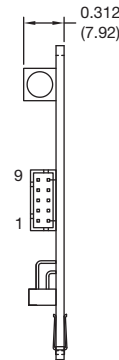

Fan Speed Control Module Connector Pinouts	
Pin	Function
1	Fan Fail
2	Fan Fail
3	Not Used
4	Not Used
5	Not Used
6	Not Used
7	Not Used
8	Not Used
9	Ground
10	Ground

Notes

- All dimensions in inches (mm).
Tolerance: x.xx = ±0.02 (±0.50), x.xxx = ±0.01 (±0.25)
- Mating plug: JST p/n PHDR-10VS.
- Contact: 26-22 AWG JST p/n SPHD-001T-P0.5.

Parallel Connection

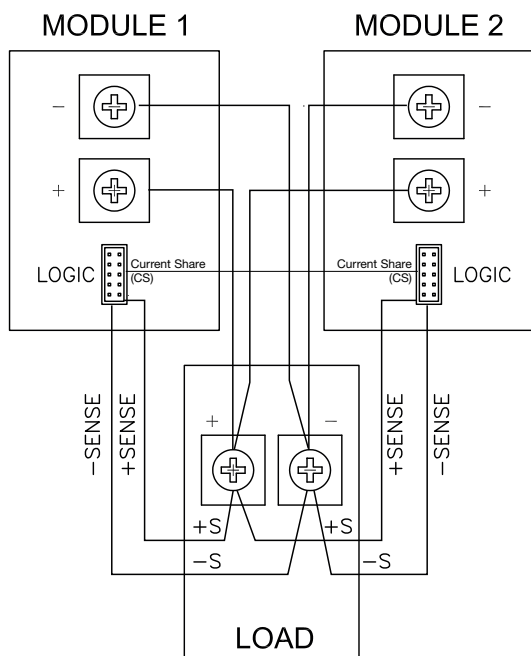

Series Connection

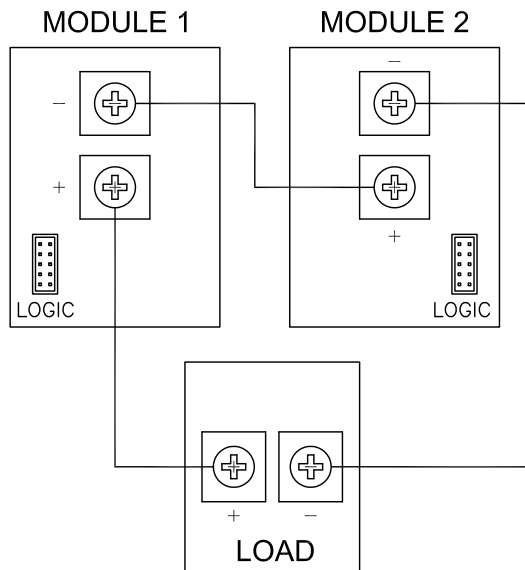

Use of DC OK Signal for Modules in Parallel or Series

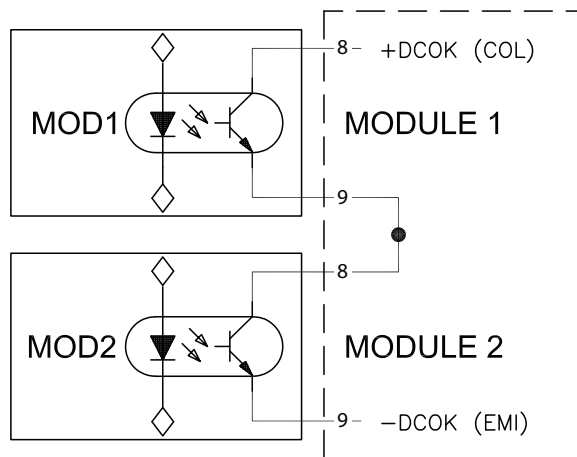

Use of Module Inhibit for Modules in Parallel or Series

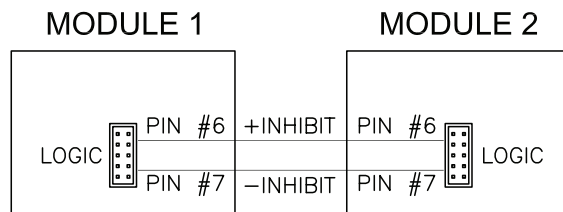

Mechanical Details

400 (600)⁽⁴⁾ Watt X4 & XM4 Chassis, 500 (700)⁽⁴⁾ Watt X5 & XM5 Chassis, 700 (900)⁽⁴⁾ Watt X7 & XM7 Chassis

Weight: 2.75 lb (1250 g) approx.

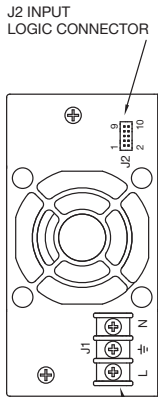

AC INPUT TERMINAL BLOCK M3.5 HARDWARE, 0.375 (9.52) CENTERS TORQUE: 9-10 IN-LB (0.104-0.115 KG-M)

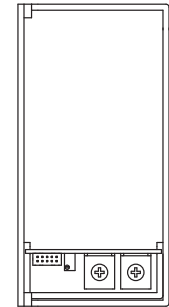
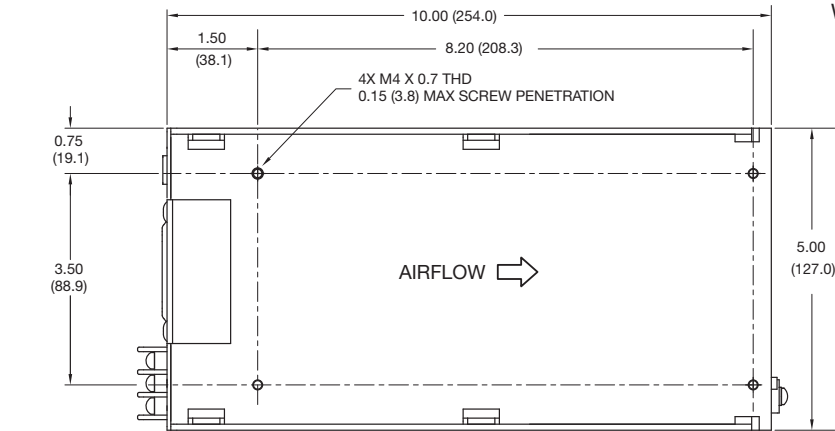

SHOWN WITH 2-SLOT-WIDTH MODULE FOR REFERENCE

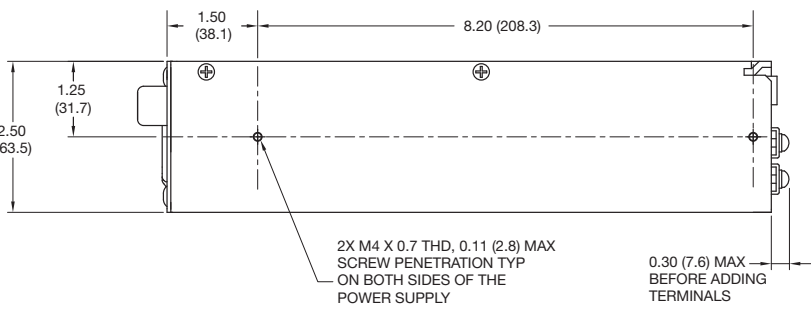

2X M4 X 0.7 THD, 0.11 (2.8) MAX SCREW PENETRATION TYP ON BOTH SIDES OF THE POWER SUPPLY

0.30 (7.6) MAX BEFORE ADDING TERMINALS

J2 Input Logic Connector Pinouts	
Pin	Function
1	Global Inhibit Return
2	Global Inhibit
3	Global DC OK Emitter
4	Global DC OK Collector
5	Global AC OK Emitter
6	Global AC OK Collector
7	5V Standby
8	5V Standby Return
9	Not used
10	Not used

900 (1100)⁽⁴⁾ Watt X9 & XM9 Chassis

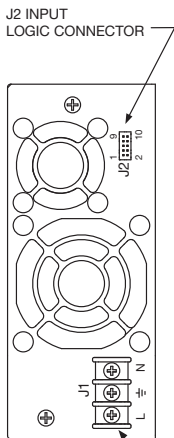

AC INPUT TERMINAL BLOCK M3.5 HARDWARE, 0.375 (9.52) CENTERS TORQUE: 9-10 IN-LB (0.104-0.115 KG-M)

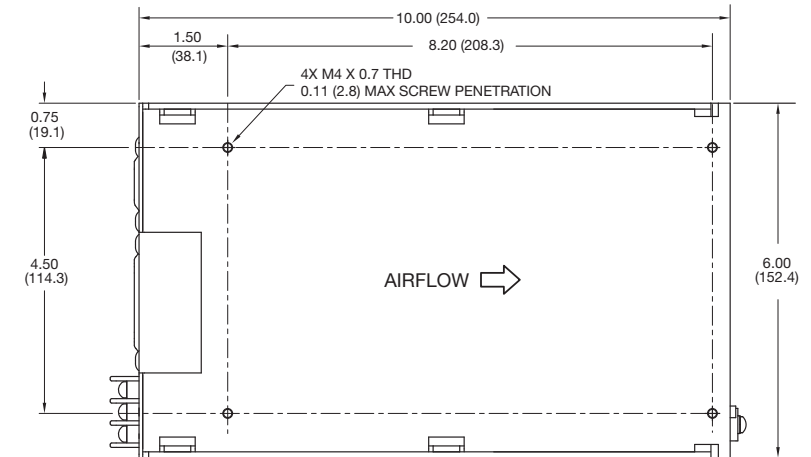

SHOWN WITH 2-SLOT-WIDTH MODULE FOR REFERENCE

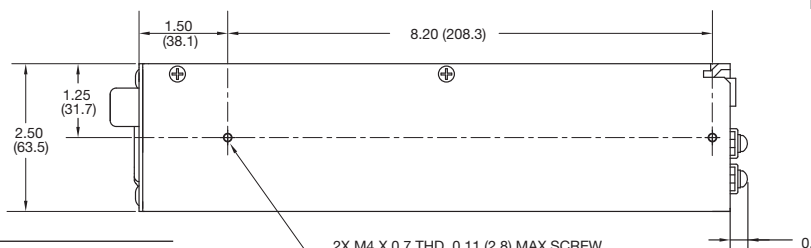

2X M4 X 0.7 THD, 0.11 (2.8) MAX SCREW PENETRATION TYP ON BOTH SIDES OF THE POWER SUPPLY

0.30 (7.6) MAX BEFORE ADDING TERMINALS

Weight: 3.3 lb (1500 g) approx.

Notes

- All dimensions in inches (mm).
Tolerance: x.xx = ±0.02 (±0.50), x.xxx = ±0.01 (±0.25)
- Mating plug: JST p/n PHDR-10VS.
- Contact: 26-22 AWG JST p/n SPHD-001T-P0.5.
- High line only (180-264 VAC).

Mechanical Details

1000 (1200)⁽⁴⁾ Watt X10 & XM10 Chassis

Weight: 4 lb (1800 g) approx.

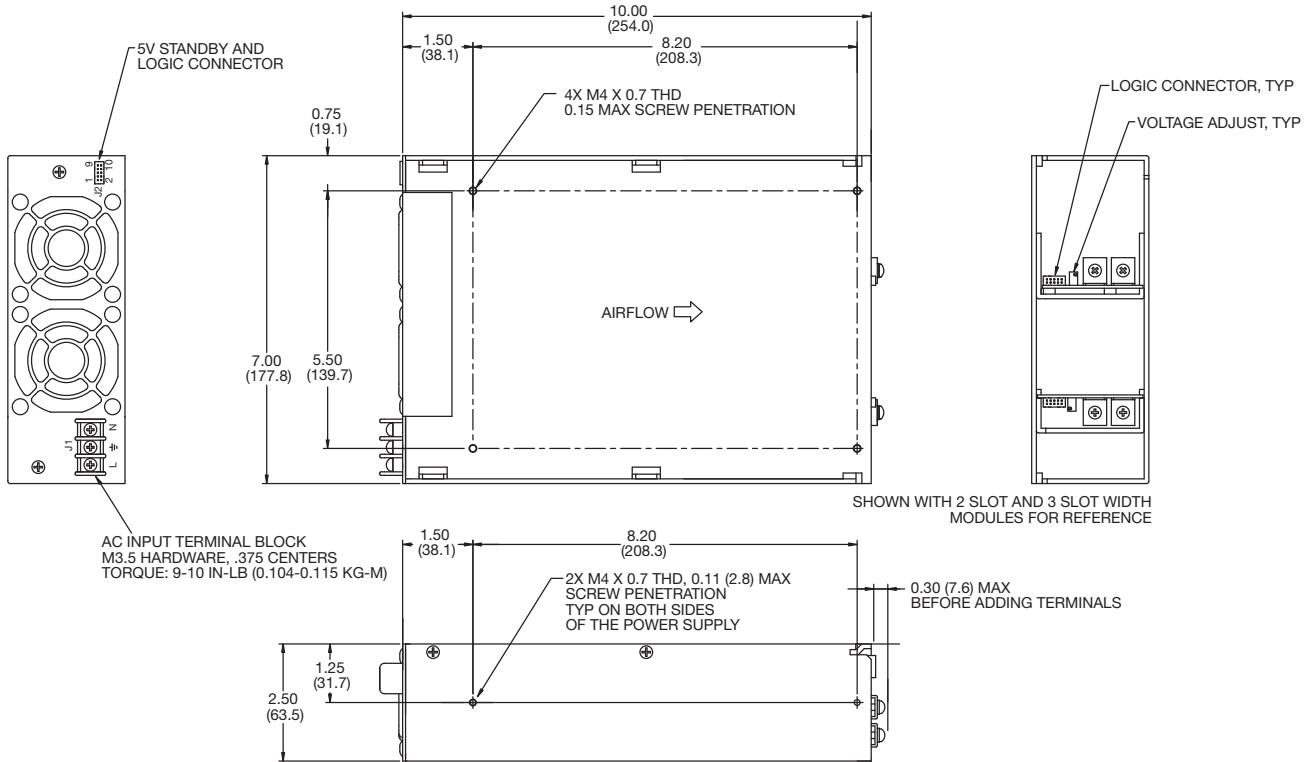

J2 Input Logic Connector Pinouts	
Pin	Function
1	Global Inhibit Return
2	Global Inhibit
3	Global DC OK Emitter
4	Global DC OK Collector
5	Global AC OK Emitter
6	Global AC OK Collector
7	5V Standby
8	5V Standby Return
9	Manufacturer Use Only
10	Manufacturer Use Only

Notes

1. All dimensions in inches (mm). Tolerance: x.xx = ±0.02 (±0.50), x.xxx = ±0.01 (±0.25)
2. Mating plug: JST p/n PHDR-10VS.
3. Contact: 26-22 AWG JST p/n SPHD-001T-P0.5.
4. High line only (180-264 VAC).

Mechanical Details

800 (1200)⁽⁴⁾ Watt X4DD & XM4DD Chassis, 1000 (1400)⁽⁴⁾ Watt X5DD & XM5DD Chassis,
1400 (1800)⁽⁴⁾ Watt X7DD & XM7DD Chassis

Weight: 5.5 lb (2500 g) approx.

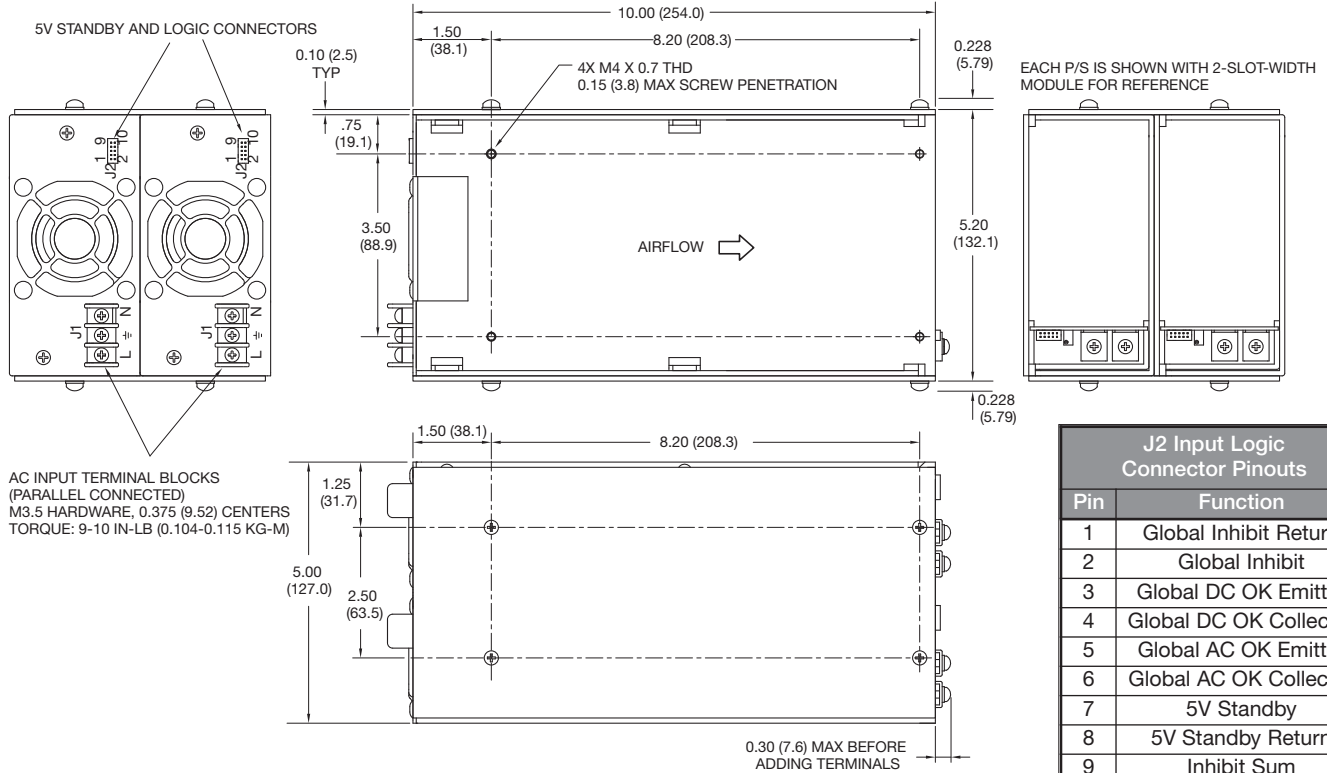

1800 (2200)⁽⁴⁾ Watt X9DD & XM9DD Chassis

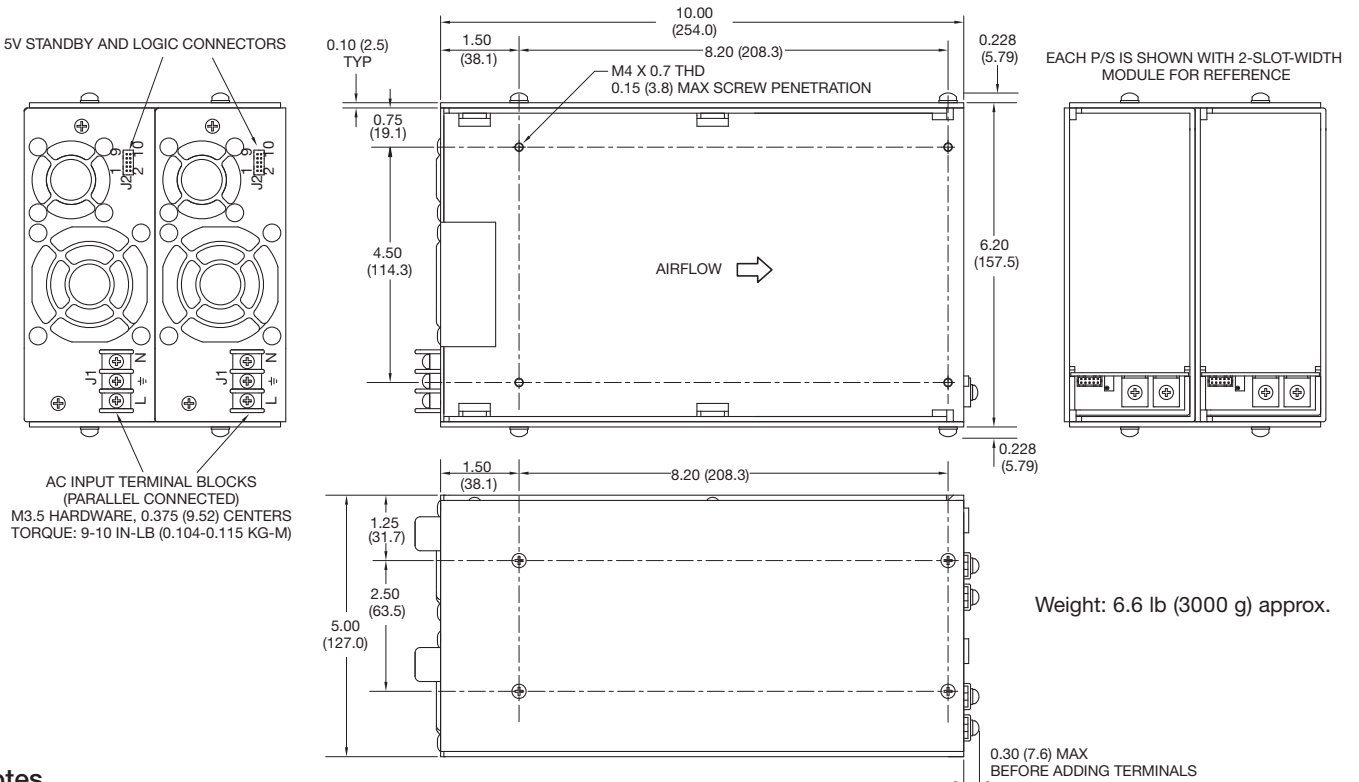

Notes

- All dimensions in inches (mm).
Tolerance: x.xx = ±0.02 (±0.50), x.xxx = ±0.01 (±0.25)
- Mating plug: JST p/n PHDR-10VS.
- Contact: 26-22 AWG JST p/n SPHD-001T-P0.5.
- High line only (180-264 VAC)

Mechanical Details

2000 (2400)⁽⁴⁾ Watt X10DD & XM10DD Chassis

Weight: 8.0 lb (3636 g) approx.

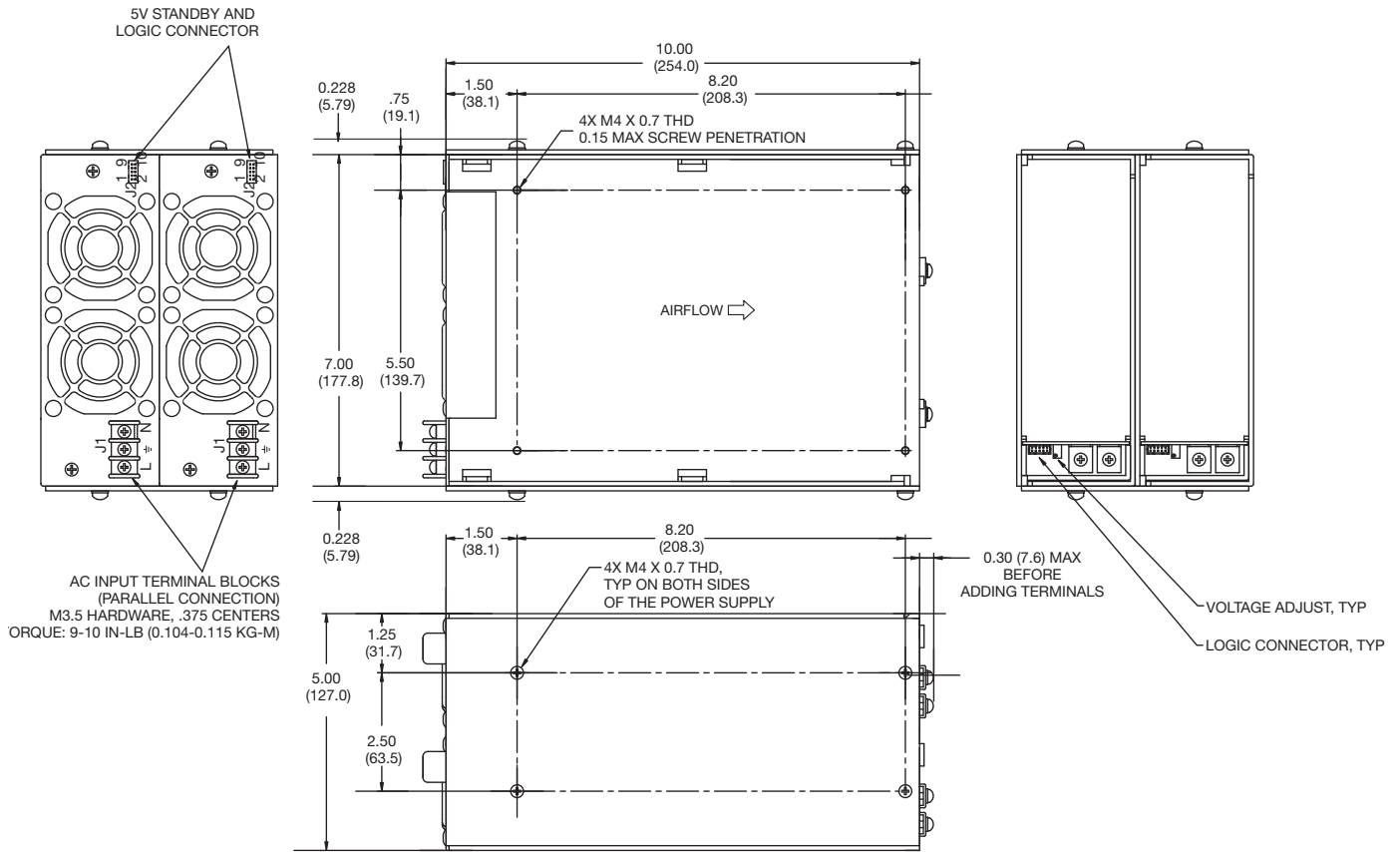

J2 Input Logic Connector Pinouts	
Pin	Function
1	Global Inhibit Return
2	Global Inhibit
3	Global DC OK Emitter
4	Global DC OK Collector
5	Global AC OK Emitter
6	Global AC OK Collector
7	5V Standby
8	5V Standby Return
9	Inhibit Sum
10	VCC Return

Notes

1. All dimensions in inches (mm). Tolerance: x.xx = ±0.02 (±0.50), x.xxx = ±0.01 (±0.25)
2. Mating plug: JST p/n PHDR-10VS.
3. Contact: 26-22 AWG JST p/n SPHD-001T-P0.5.
4. High line only (180-264 VAC).

Chassis Mechanical Details

1500 (2500)⁽⁴⁾ Watt X15 & XM15 Chassis

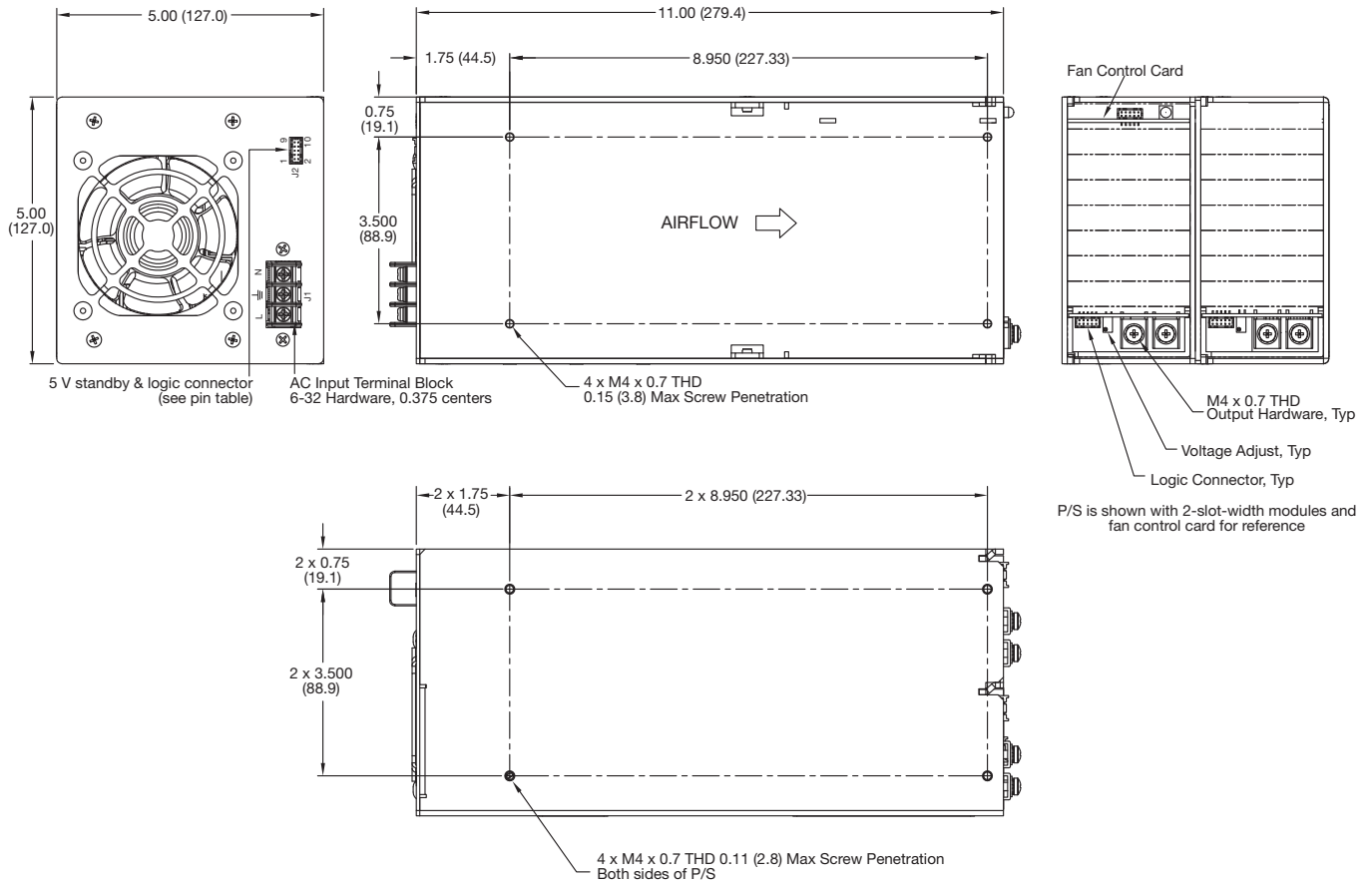

J2 Input Logic Connector Pinouts	
Pin	Function
1	Global Inhibit Return
2	Global Inhibit
3	Global DC OK Emitter
4	Global DC OK Collector
5	Global AC OK Emitter
6	Global AC OK Collector
7	5V Standby
8	5V Standby Return
9	Inhibit Sum (Internal Use Only)
10	VCC Return (Internal Use Only)

Notes

- All dimensions in inches (mm).
Tolerance X.XX = ±0.02 (0.05), X.XXX = ±0.01 (0.25)
- Mating plug: JST p/n PHDR-10VS.
- Contact: 26-22 AWG JST p/n SPHD-001T-P0.5.
- High line only (180-264 VAC).
- Weight: 8.0 lbs (3636 g) approx.

Output Characteristics - Hold Up Time

Hold Up Time X4

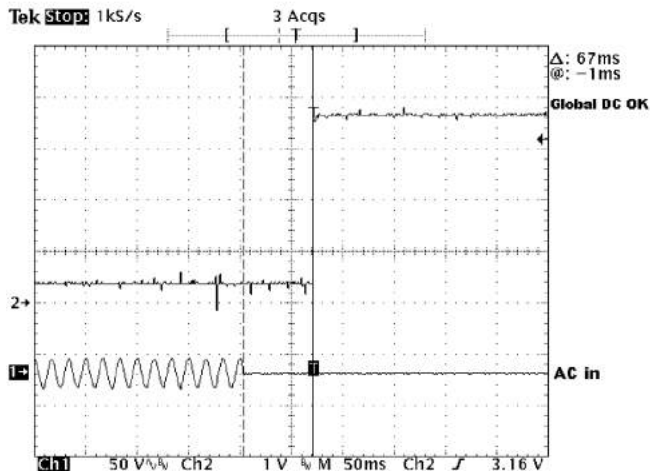

Hold Up Time X5

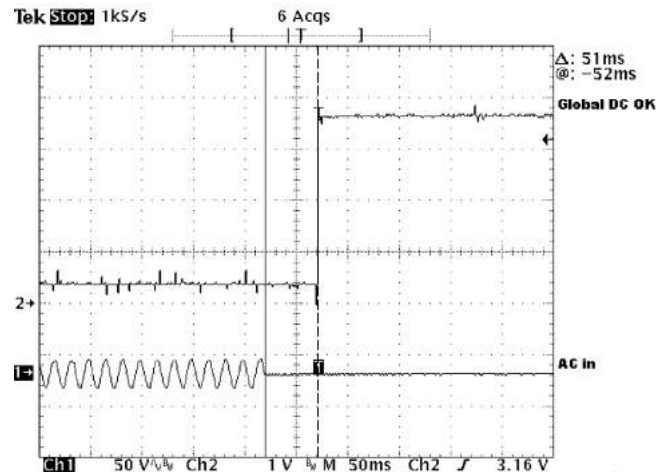

Hold Up Time X7

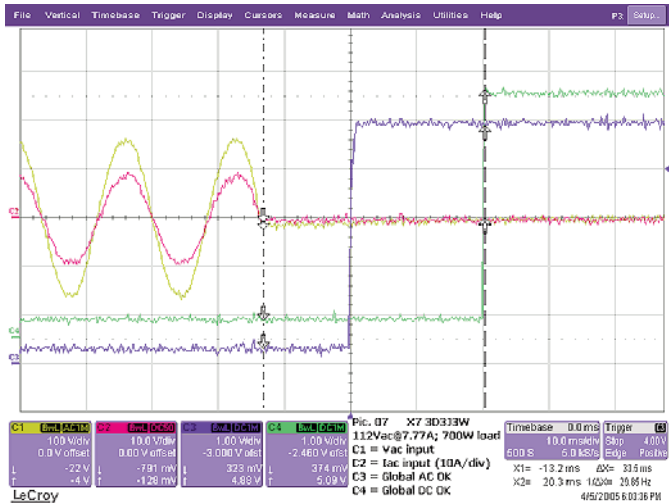

Hold Up Time X7 with 900 W load

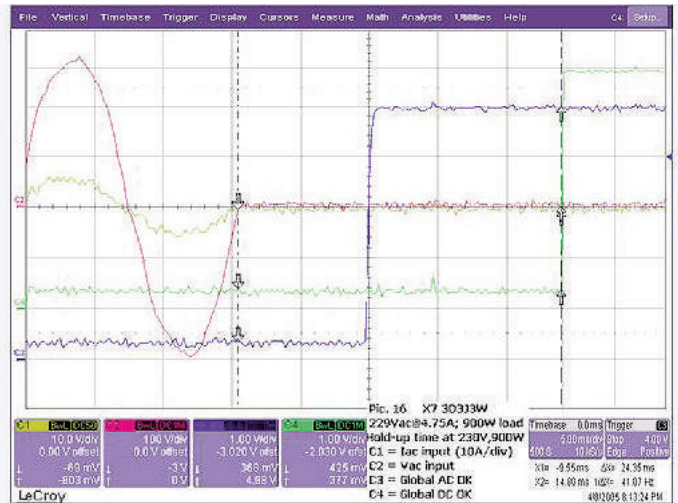

Hold Up Time X9

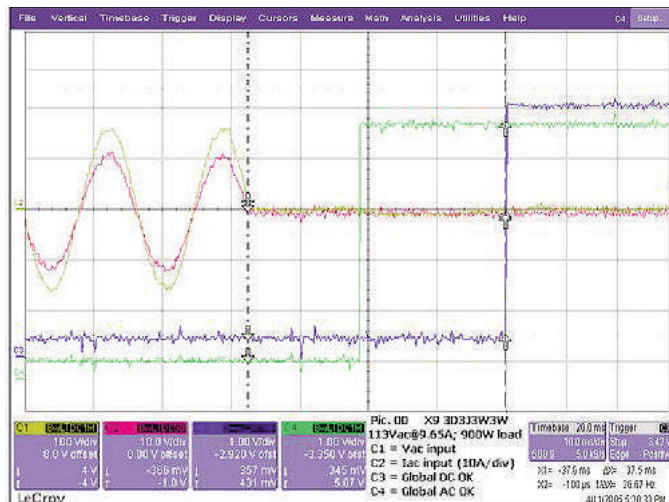

Hold Up Time X9 with 1100 W load

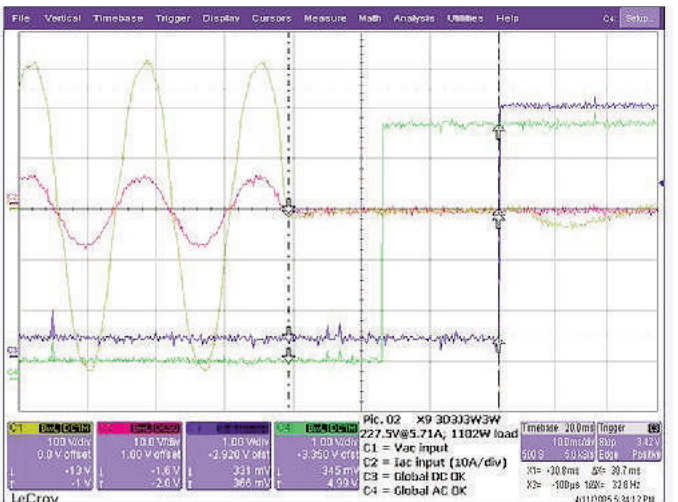

Output Characteristics - Hold Up Time - Continued

Hold Up Time X10

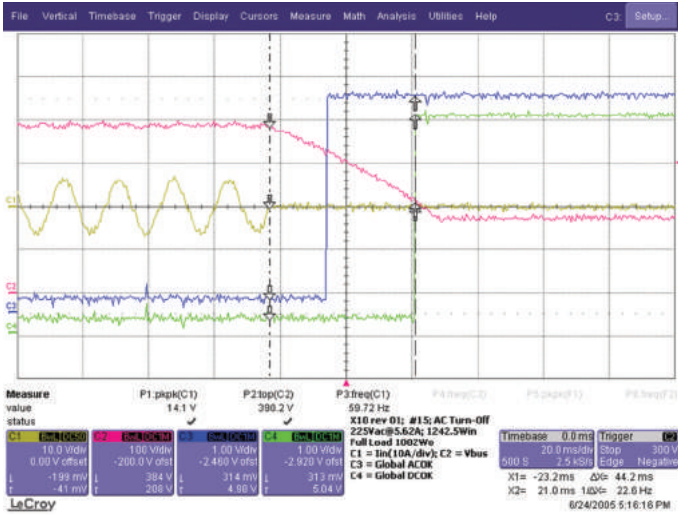

Hold Up Time X10 with 1200 W load

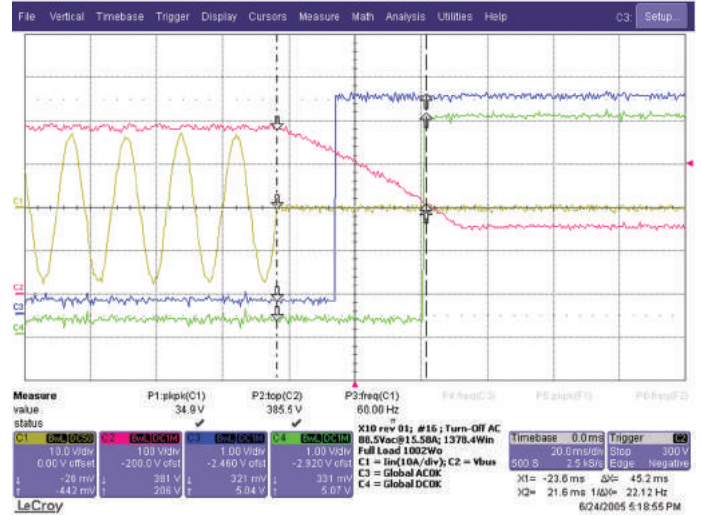

Hold Up Time X15

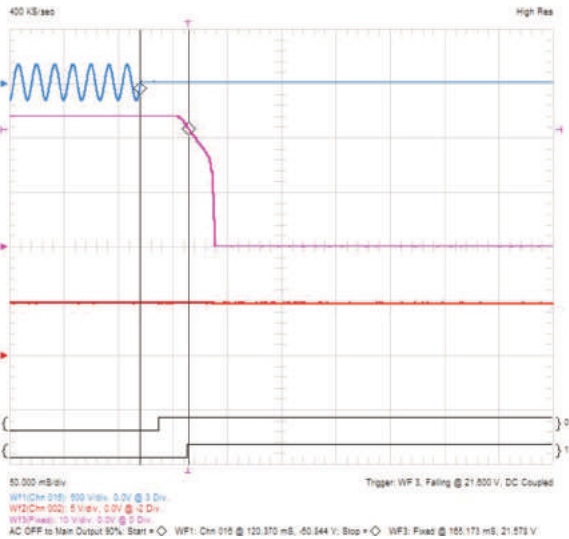

Hold Up Time X15 with 2500 W load

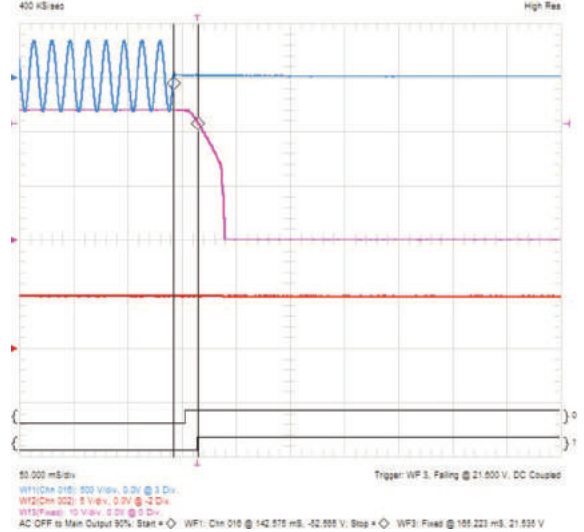

Output Power Derating

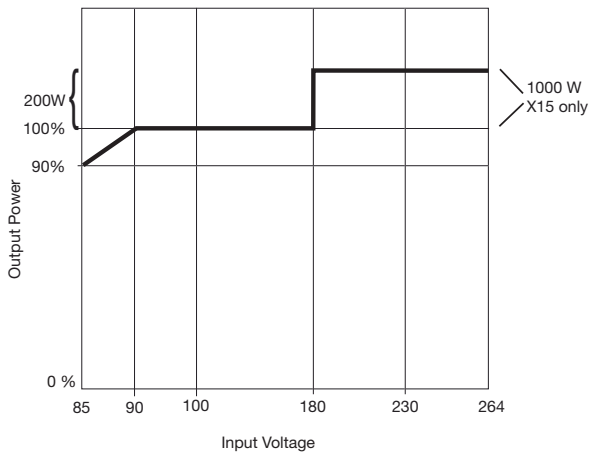

Load derating curve for X4, X5, X7, X9, X10, X15

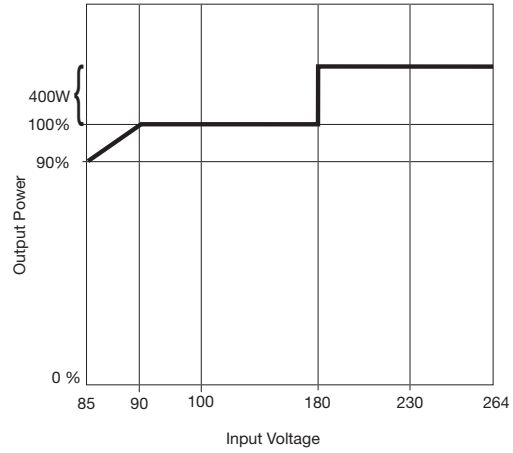

Load derating curve for X4DD, X5DD, X7DD, X9DD and X10DD

Efficiency

X7 Models

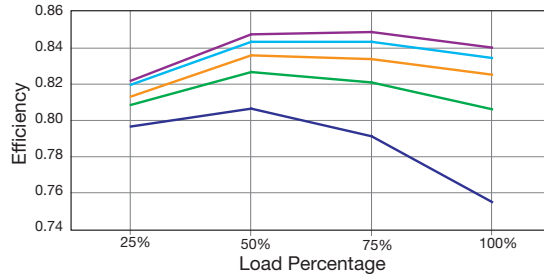

F7	25%	50%	75%	100%
85 V	0.796	0.806	0.791	0.755
115 V	0.808	0.826	0.821	0.806
150 V	0.813	0.836	0.834	0.825
200 V	0.819	0.843	0.843	0.834
250 V	0.822	0.847	0.849	0.840

X9 Models

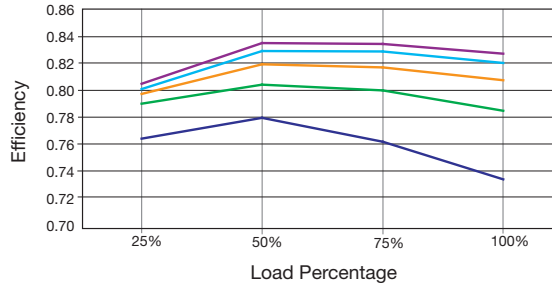

F9	25%	50%	75%	100%
85 V	0.763	0.779	0.761	0.733
115 V	0.790	0.804	0.799	0.784
150 V	0.797	0.819	0.816	0.807
200 V	0.800	0.829	0.828	0.820
250 V	0.804	0.834	0.834	0.827

X10 Models

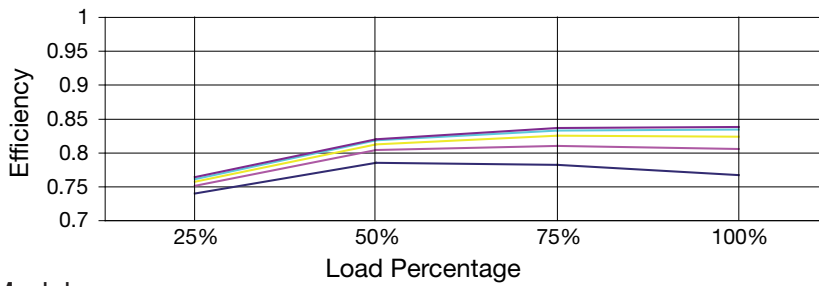

F7	25%	50%	75%	100%
85 V	0.739	0.784	0.781	0.766
115 V	0.750	0.803	0.809	0.804
150 V	0.756	0.811	0.824	0.822
200 V	0.760	0.817	0.832	0.833
250 V	0.763	0.819	0.835	0.837

X10DD Models

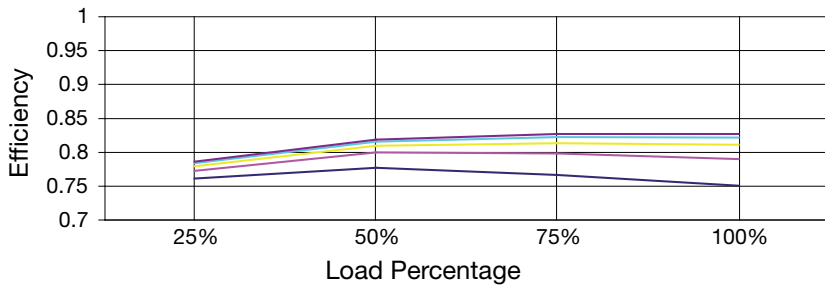

F9	25%	50%	75%	100%
85 V	0.760	0.775	0.765	0.749
115 V	0.771	0.798	0.797	0.789
150 V	0.778	0.808	0.812	0.810
200 V	0.782	0.814	0.821	0.820
250 V	0.785	0.817	0.826	0.825

X15 Models

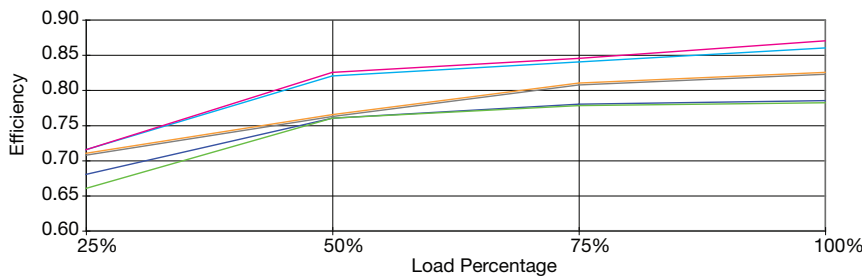

F9	25%	50%	75%	100%
85 V	0.680	0.760	0.780	0.785
90 V	0.680	0.760	0.778	0.782
115 V	0.710	0.765	0.810	0.825
230 V	0.715	0.820	0.840	0.860
246 V	0.715	0.825	0.845	0.870

Output Characteristics - Transient Response



5 V/40 A Module, 50 to 100% load Change

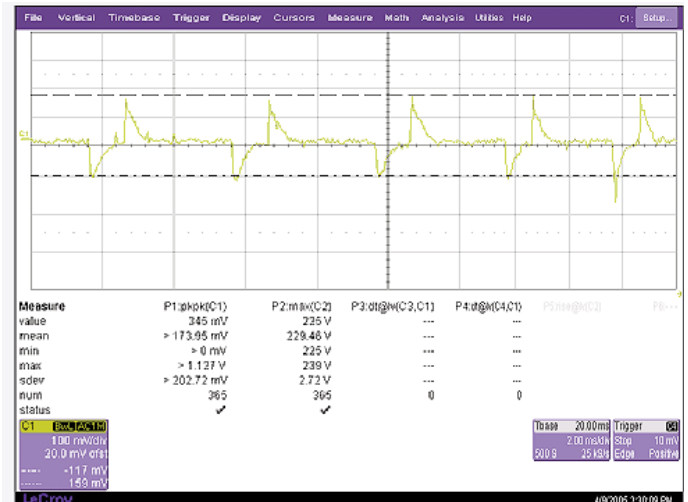

5 V/60 A Module, 50 to 100% load Change

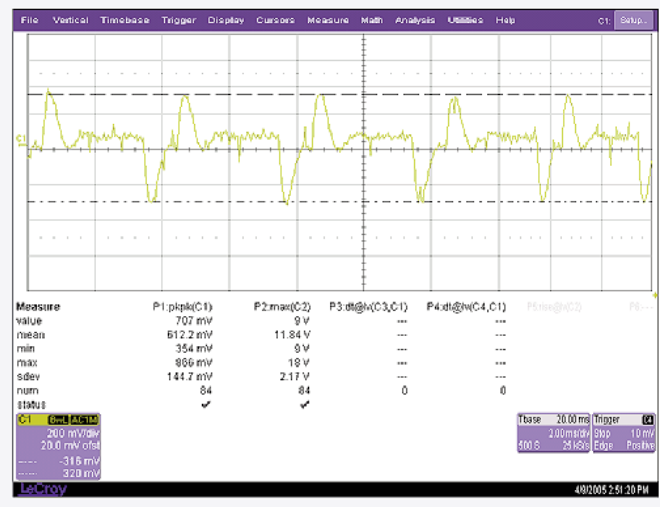

48 V/5.2 A Module, 50 to 100% load Change

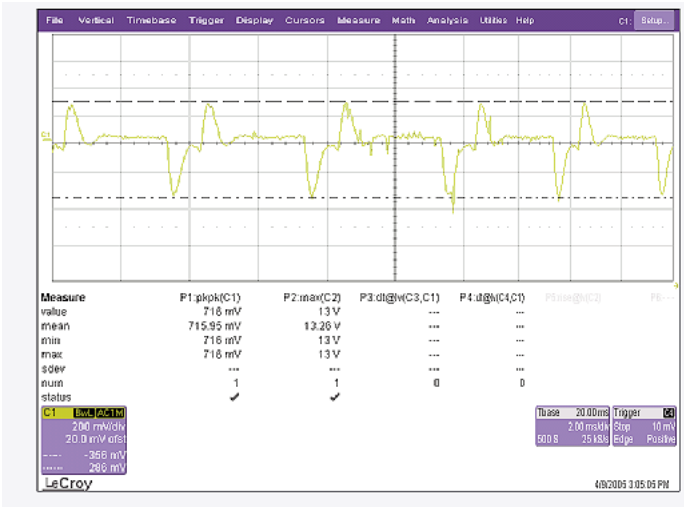

48 V/8.5 A Module, 50 to 100% load Change

Output Characteristics - Ripple & Noise

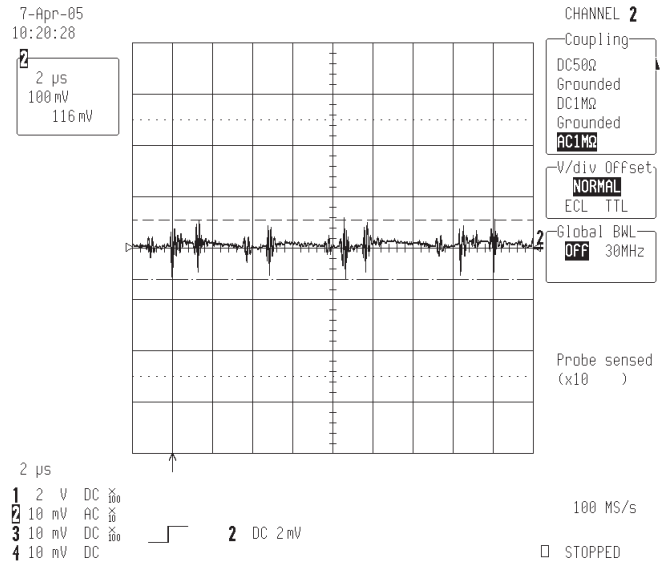
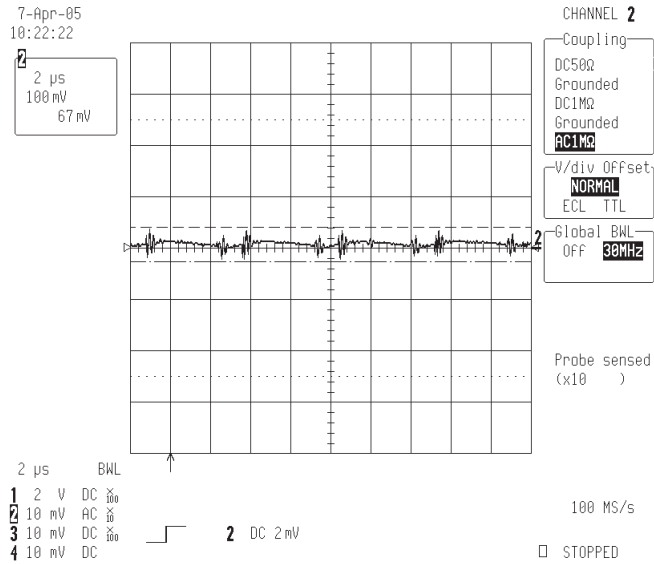

5 V Output Ripple and Noise at 30 MHz

5 V Output Ripple and Noise at 150 MHz

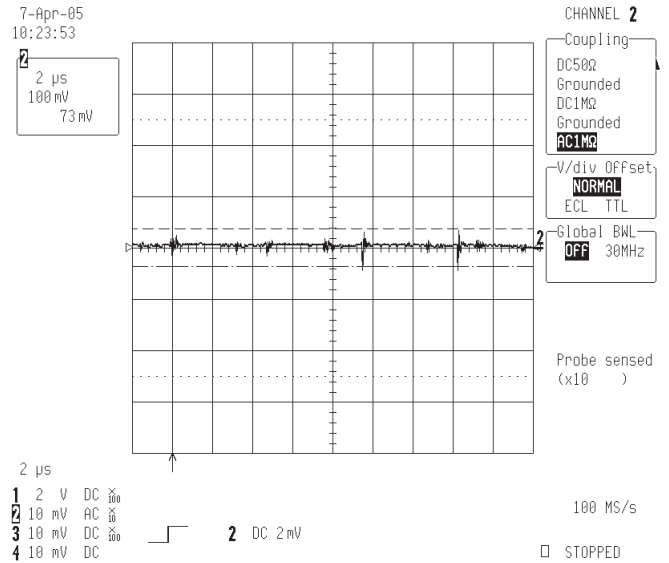
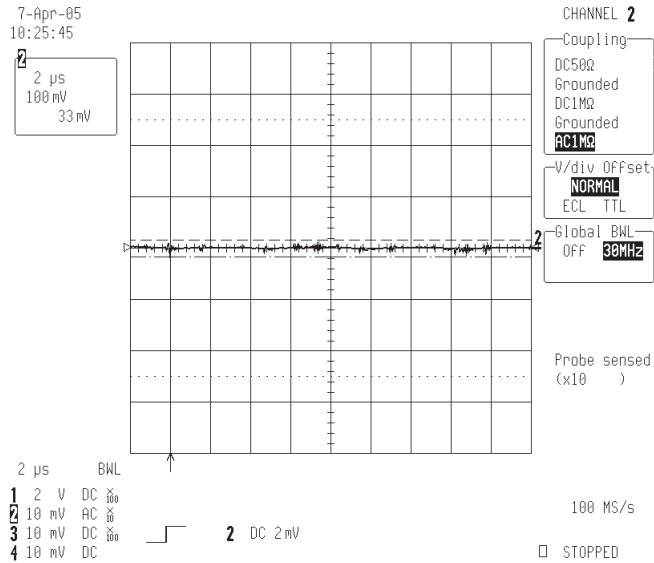

48 V Output Ripple and Noise at 30 MHz

48 V Output Ripple and Noise at 150 MHz

Harmonics

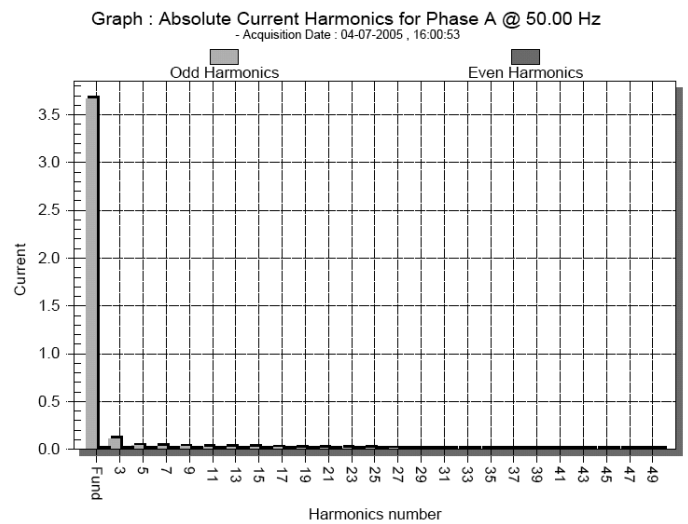
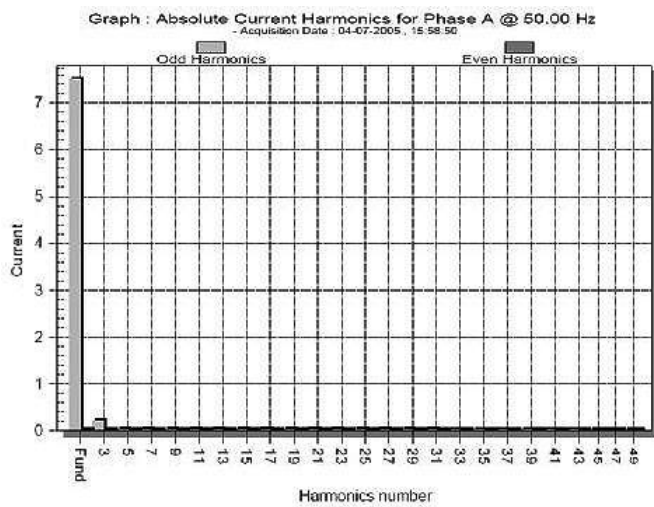

Harmonics 1: X7 50 Hz 115 V

Harmonics 2: X7 50 Hz 230 V

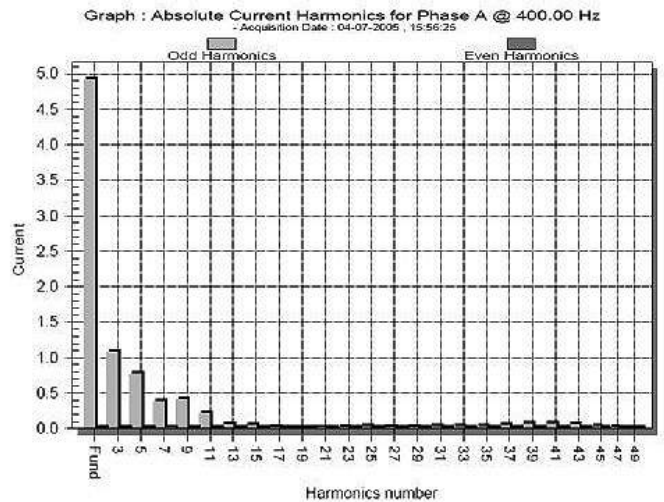
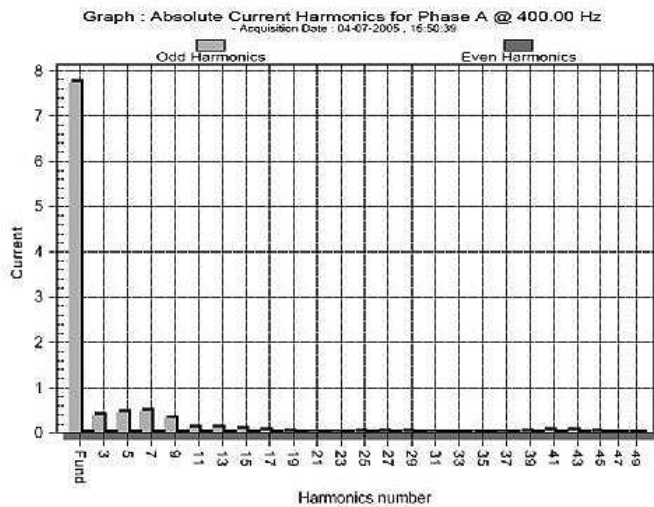

Harmonics 3: X7 400 Hz 115 V

Harmonics 4: X7 400 Hz 230 V

Harmonics

Graph : Absolute Current Harmonics for Phase A @ 50.00 Hz
- Acquisition Date : 04-11-2005 , 09:44:33

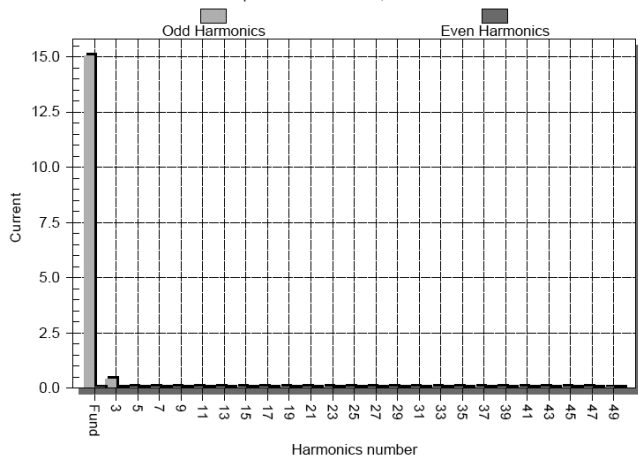

Harmonics 5: X7 DD 50 Hz 115 V

Graph : Absolute Current Harmonics for Phase A @ 50.00 Hz
- Acquisition Date : 04-11-2005 , 09:45:57

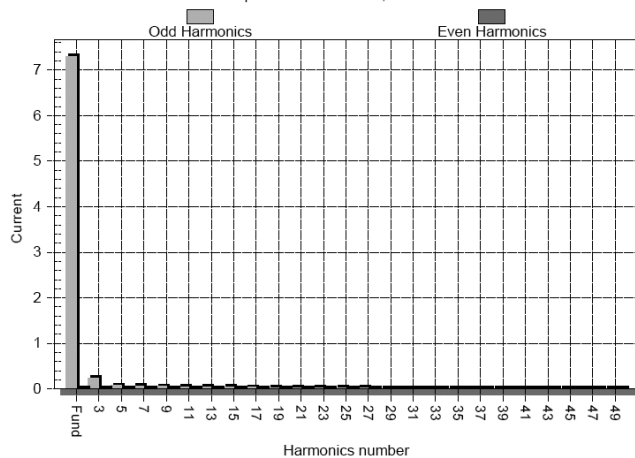

Harmonics 6: X7 DD 50 Hz 230 V

Graph : Absolute Current Harmonics for Phase A @ 400.00 Hz
- Acquisition Date : 04-11-2005 , 09:48:31

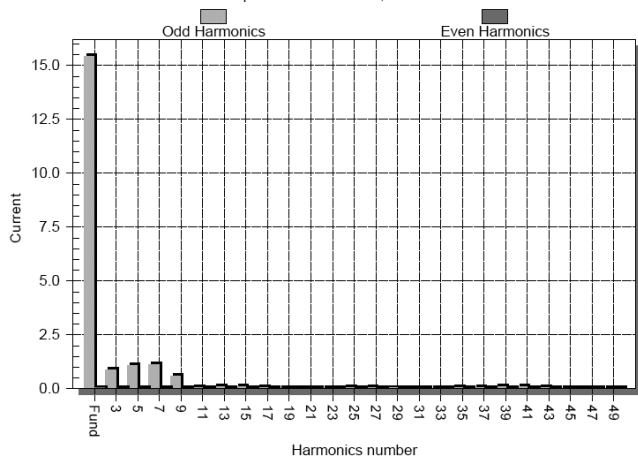

Harmonics 7: X7 DD 400 Hz 115 V

Graph : Absolute Current Harmonics for Phase A @ 400.00 Hz
- Acquisition Date : 04-11-2005 , 09:47:01

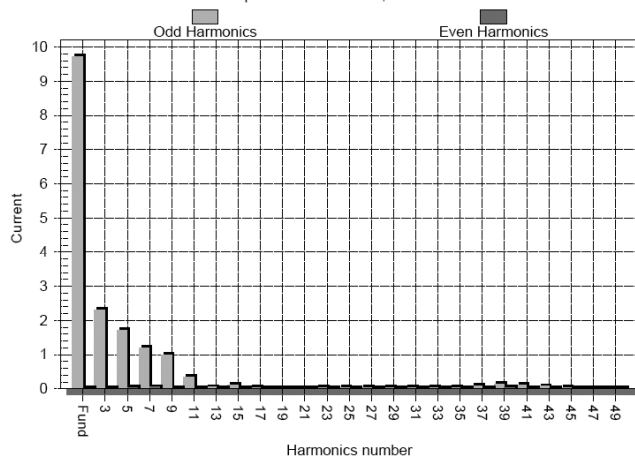

Harmonics 8: X7 DD 400 Hz 230 V

Harmonics

Graph : Absolute Current Harmonics for Phase A @ 400.00 Hz
- Acquisition Date : 04-08-2005 , 16:03:05

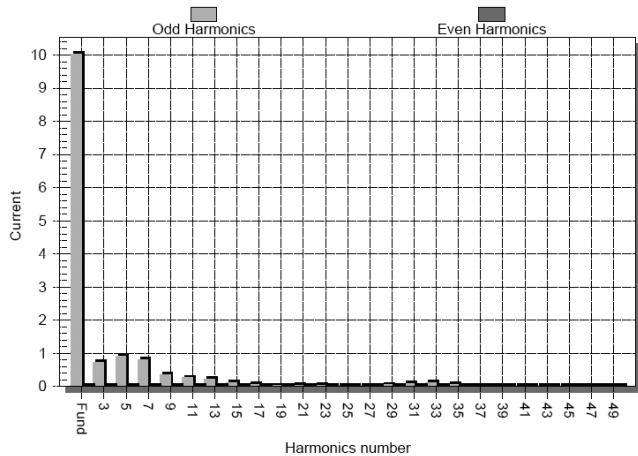

Harmonics 9: X9 50 Hz 115 V

Graph : Absolute Current Harmonics for Phase A @ 50.00 Hz
- Acquisition Date : 04-08-2005 , 15:57:56

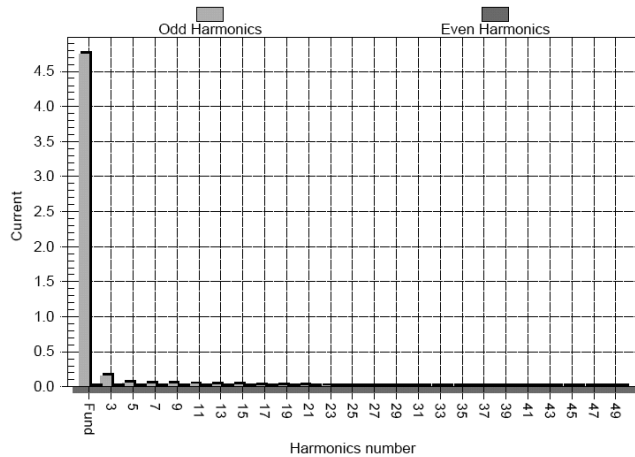

Harmonics 10: X9 50 Hz 230 V

Graph : Absolute Current Harmonics for Phase A @ 400.00 Hz
- Acquisition Date : 04-08-2005 , 16:03:05

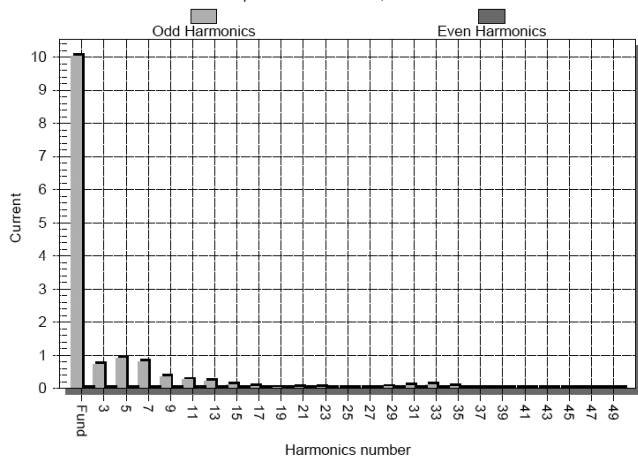

Harmonics 11: X9 400 Hz 115 V

Graph : Absolute Current Harmonics for Phase A @ 400.00 Hz
- Acquisition Date : 04-08-2005 , 16:06:26

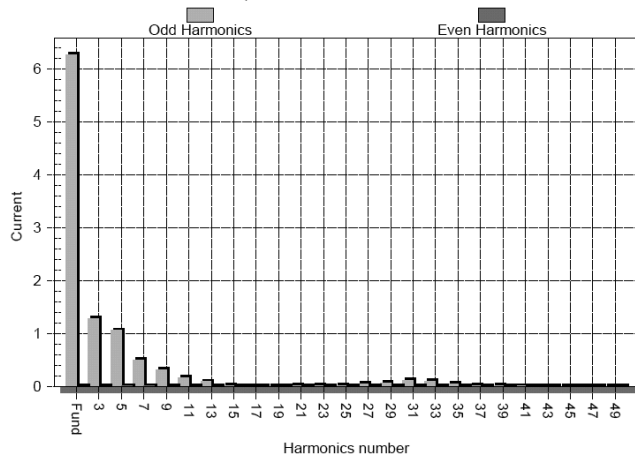

Harmonics 12: X9 400 Hz 230 V

Harmonics

Graph : Absolute Current Harmonics for Phase A @ 50.00 Hz
- Acquisition Date : 04-11-2005 , 09:06:58

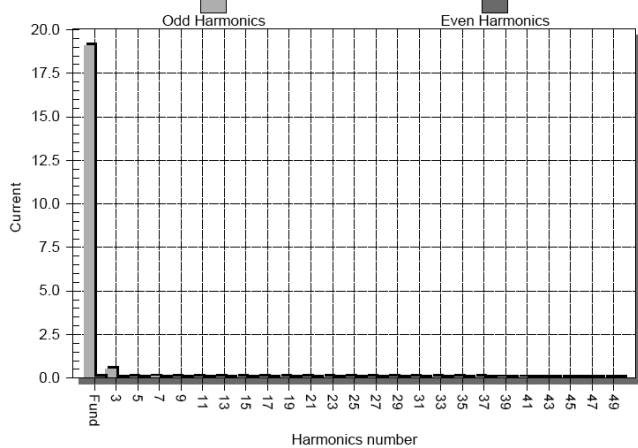

Graph : Absolute Current Harmonics for Phase A @ 50.00 Hz
- Acquisition Date : 04-11-2005 , 09:08:58

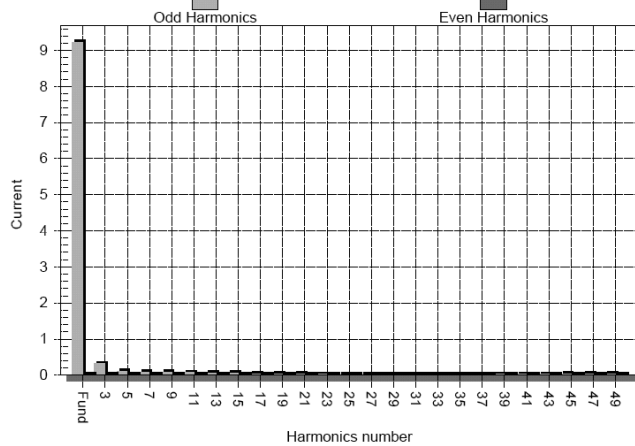

Harmonics 13: X9 DD 50 Hz 115 V

Harmonics 14: X9 DD 50 Hz 230 V

Graph : Absolute Current Harmonics for Phase A @ 400.00 Hz
- Acquisition Date : 04-11-2005 , 09:14:23

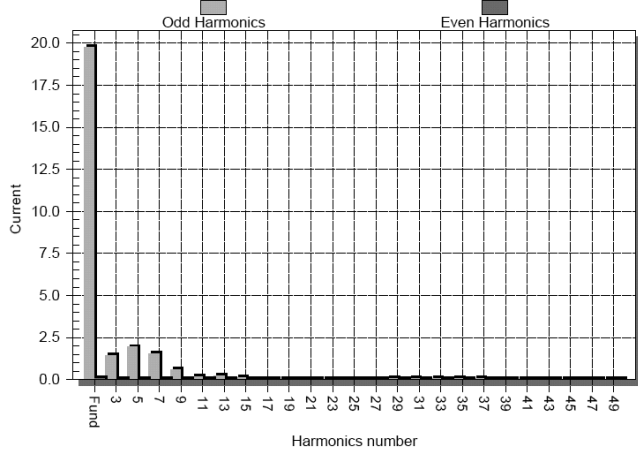

Graph : Absolute Current Harmonics for Phase A @ 400.00 Hz
- Acquisition Date : 04-11-2005 , 09:11:46

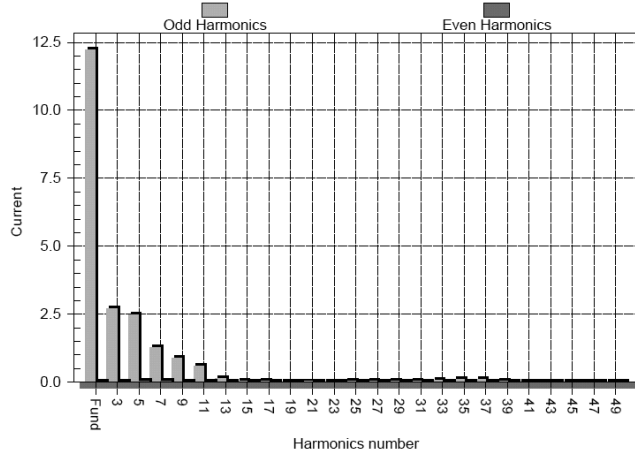

Harmonics 15: X9 DD 400 Hz 115 V

Harmonics 16: X9 DD 400 Hz 230 V

Harmonics

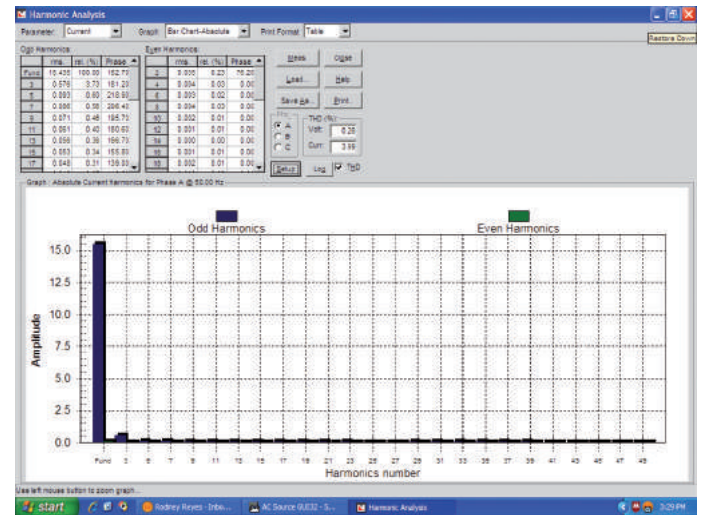
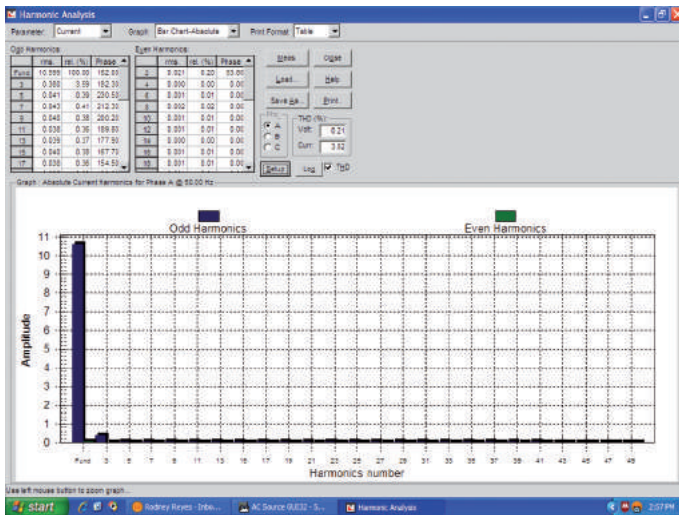

Harmonics 17: X10 50 Hz 115 V

Harmonics 18: X10 50 Hz 230 V

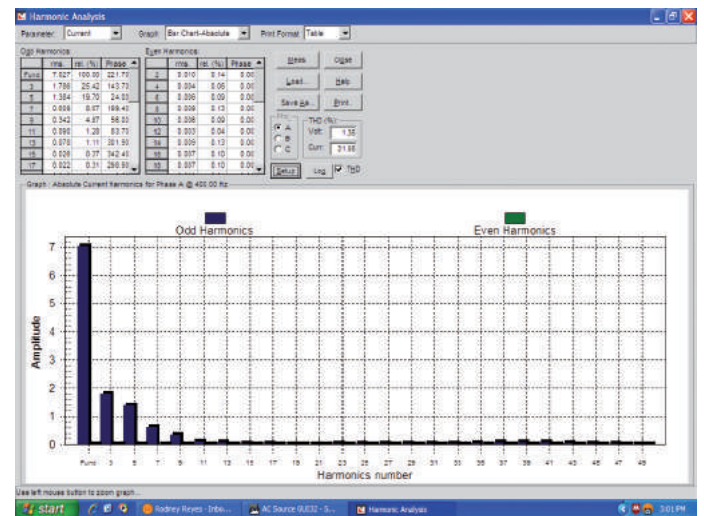
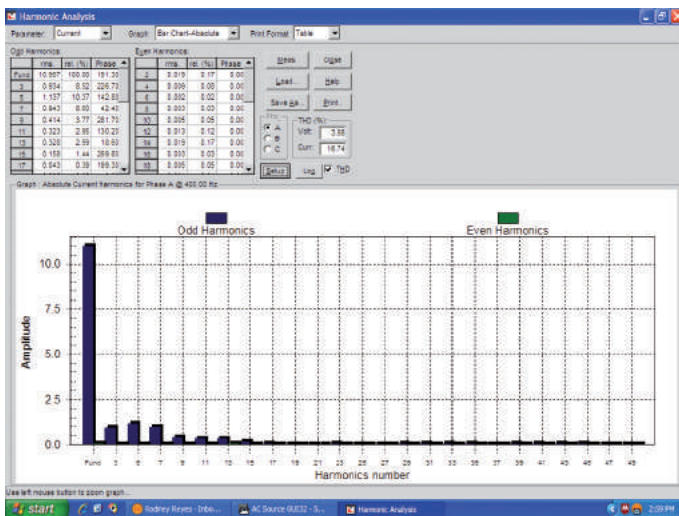

Harmonics 19: X10 400 Hz 115 V

Harmonics 20: X10 400 Hz 230 V

Harmonics

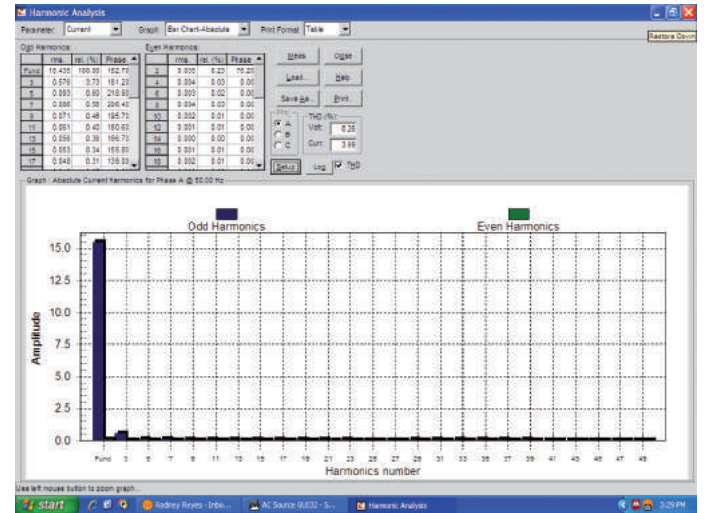
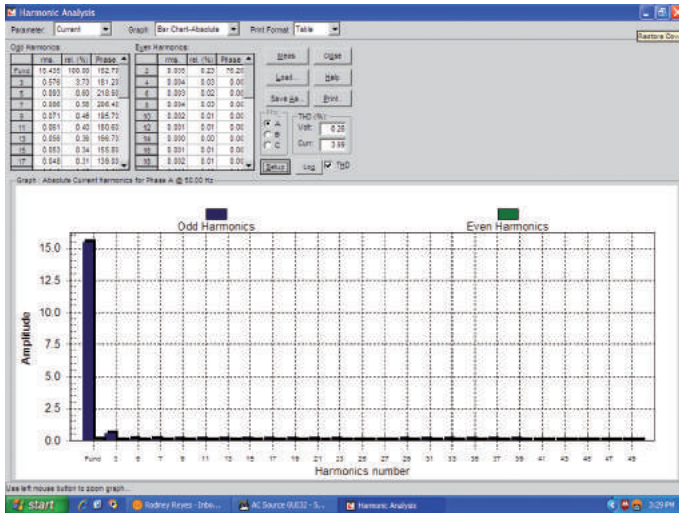

Harmonics 21: X10 DD 50 Hz 115 V

Harmonics 22: X10 DD 50 Hz 230 V

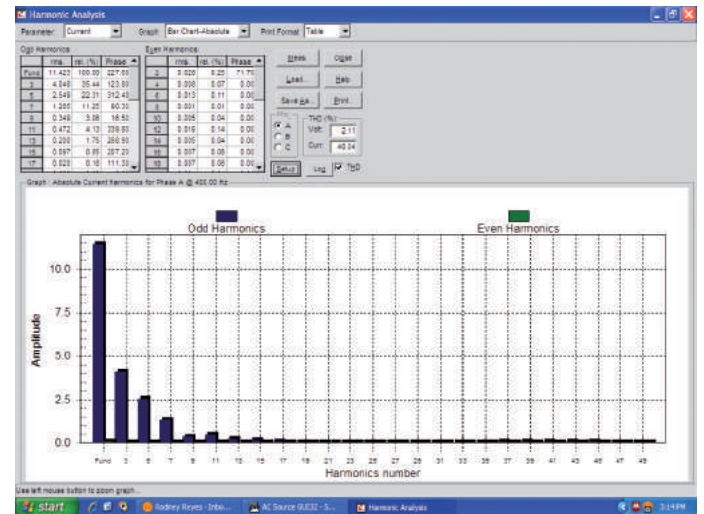
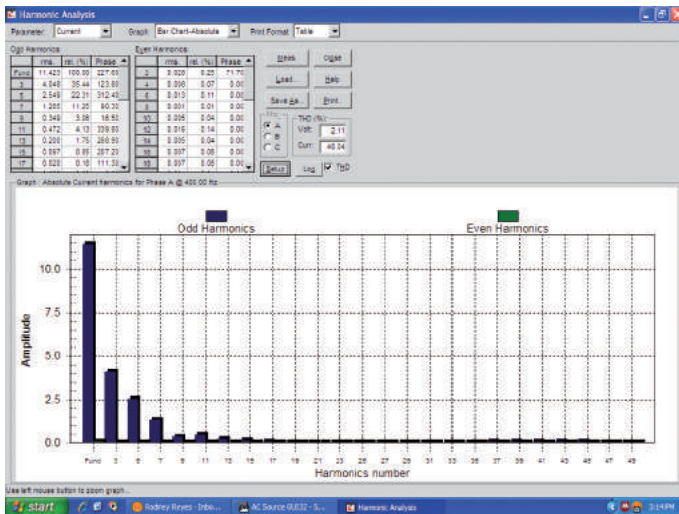

Harmonics 23: X10 DD 400 Hz 115 V

Harmonics 24: X10 DD 400 Hz 230 V

Harmonics

Harmonics and Class D limit line European Limits

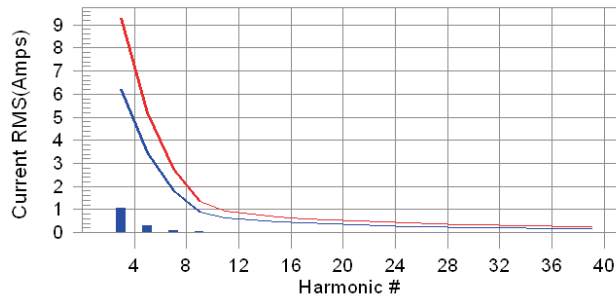

Test result: Pass Worst harmonic was #3 with 11.50% of the limit.

Harmonics 25: X15 120 V 50 Hz

Harmonics and Class D limit line European Limits

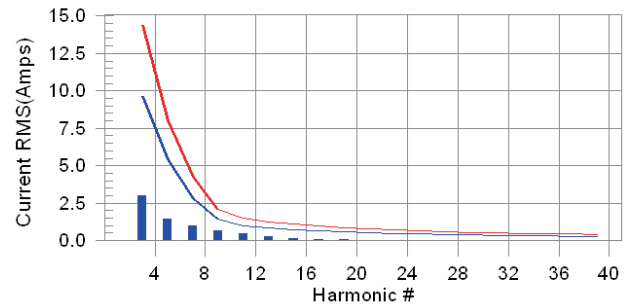

Test result: Pass Worst harmonic was #1 with 32.64% of the limit.

Harmonics 26: X15 230 V 50 Hz

Harmonics and Class A limit line European Limits

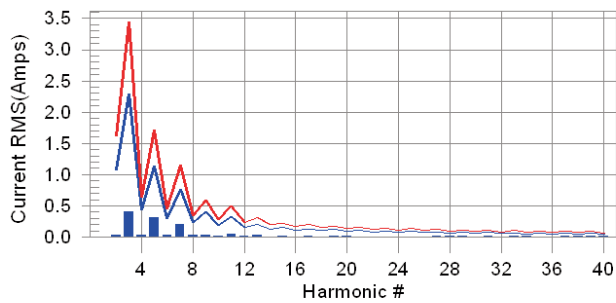

Test result: Pass Worst harmonic was #39 with 23.81% of the limit.

MHarmonics 27: X15 120 V 60 Hz

Harmonics and Class A limit line European Limits

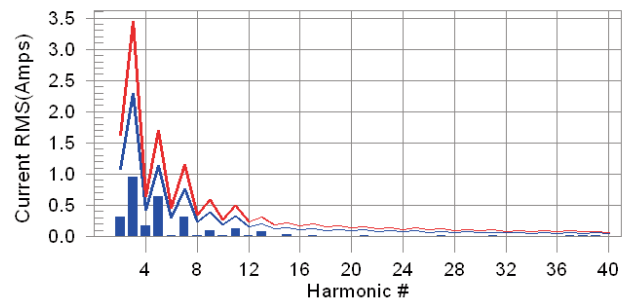

Test result: Pass Worst harmonic was #5 with 37.86% of the limit.

Harmonics 28: XM15 230 V 50 Hz