

HPS-iSTS-F1
User Manual
Wall Mount Static Transfer Switch

Australia: sales@heliosps.com.au - New Zealand: sales@heliosps.co.nz - Asia & Middle East: sales@heliosps.asia

CONTENTS

1. SAFETY INSTRUCTIONS	2
1.1 Introduction	2
1.2 Transport, Storage, Unpacking	2
1.3 Installation	2
1.4 Maintenance Bypass	3
1.5 Fire Regulations	3
1.6 Standards Applied & Conformity	3
1.7 Warranty	3
2. SYSTEM OVERVIEW & OPERATION	4
2.1 Description	4
2.2 Overview	4
2.3 Operational Parameters	5
2.4 Line Diagram: Single phase/2-Poles	5
3. OPERATION	6
3.1 Safety	6
3.2 Installation	7
3.4 Synchronism	8
3.5 Start-up	8
4. USER INTERFACE	9
4.1 Mimic Display	9
4.2 User Interface Terminals	10
4.3 Preferred Switch	10
4.4 Confirm Operation	10
5. MAINTENANCE BYPASS	11
5.1 Overview	11
5.2 Maintenance Bypass Procedure	11
5.3 Reinstatement from Maintenance Bypass	11
6. WEB BROWSER INTERFACE	12
6.1 Home Page	12
6.2 Control Panel	12
6.3 Email	13
7. FAULT Guide	14
7.1 Fault Codes	14
7.2 Load Fault	14
8. RECOMMENDED MAINTENANCE SCHEDULE	15
9. SPECIFICATIONS	16

1. SAFETY INSTRUCTIONS

1.1 Introduction

Some aspects of this manual's contents may differ to the equipment as supplied due to technical improvements, specific model variations etc. If in any doubt in respect to the procedures and safety issues consult the manufacturer and do not proceed until clarification is received.

This manual contains important instructions that should be followed and fully understood before proceeding and commissioning and operation to prevent harm to personnel and equipment.

Installation and commissioning should be carried out only by qualified and experienced electricians. The iSTS should be operated by technically qualified personnel that are authorized, experienced and have knowledge and understanding of the equipment and the critical loads, using the documented procedures.

Read this whole document thoroughly. Understand every aspect before proceeding. Request further assistance if you do not understand any aspect of the operation of the iSTS. Support and contact numbers are at the end of the manual.

These instructions cover normal operation in the automatic as well as in manual modes. Special operating conditions, such as short circuit tests, input supplies, etc., are not covered in this document. These operations require comprehensive knowledge of the overall system and should be carried out by properly qualified, skilled and competent service personnel only.

1.2 Transport, Storage, Unpacking

Procedure for Receiving Shipment:

- If the ShockWatch indicator is RED, it does not mean that damage has occurred, it only indicates that the carton received an impact or movement. If the indicator on the label is RED, make a notation to that effect on the bill of lading or delivery receipt or document. Examine contents immediately for possible damage. If damage is discovered, inform carrier immediately and follow normal procedure for a carrier inspection and filing of a concealed damage claim
- If the packaging is damaged unpack carefully and inspect the unit. We recommend that if there is any sign of mechanical damage that the unit not be powered up; but, returned for re-processing
- If damage is discovered, inform carrier immediately and follow normal procedure for a carrier inspection and filing of a concealed damage claim to the courier or your insurance company.
- Take a picture of the carton and contents as a record.
- If the packaging is OK, then please keep the packaging in a secure place in case the unit needs to be returned for repair.

1.3 Installation

The following instructions are provided for the personal safety of operators and also for the protection of the described product and connected equipment.

- Observe the prescribed accident prevention and safety rules for the specific application.
- When installing the iSTS strictly observe all information on technical data and operating conditions. Comply with all warnings, and strictly follow the procedures and practices as described in this manual.
- This iSTS is intended to be used in a controlled indoor environment and free of conductive contaminants and protected against animal intrusion.
- It is important that the unit has adequate ventilation. Maintain air movement around and through the unit. Do not block the air vents or restrict airflow over the heatsinks.
- The unit must be placed in a sufficiently ventilated area; the ambient temperature should not exceed 55°C (130°F).
- Do not install the iSTS in an excessively humid environment or near water, relative humidity should not exceed 90% at 45°C (110°F). Do not put outdoors.
- Avoid rain, spilling liquids or dropping any foreign object into the iSTS.
- Once the connections have been made on the terminals, all terminal covers must be replaced before operation.
- Connecting cables must be supported.
- Earth connection must be checked for safe function after assembly.

1.4 Maintenance Bypass

WARNING:

REFER TO THE MAINTENANCE BYPASS SECTION BEFORE ATTEMPTING TO PUT THE UNIT INTO MAINTENANCE BYPASS MODE.

THE MAINTENANCE BYPASS SWITCH UTILISES MAKE-BEFORE-BREAK SWITCHING, INCORRECT OPERATION OF THE MAINTENANCE BYPASS FEATURES COULD RESULT IN DANGEROUS VOLTAGES OCCURING AND SHORT CIRCUITS.

1.5 Fire Regulations

Should a fire break out inside the system a fire extinguisher with CO² or similar non-conductive, non-corrosive and inert gas must be used. Do not inhale vapours.

1.6 Standards Applied & Conformity

The iSTS B2 conforms to the following standards and European Council Directives:

Standards to which conformity declared:

- IEC 60950-1 Information technology equipment Safety - General requirements
- IEC 62310-1 Static transfer systems (STS) - General and safety requirements
- IEC 62310-2 Static transfer systems (STS) - Electromagnetic compatibility (EMC) requirements
- IEC 62310-3 Static transfer systems (STS) - Part 3: Method for specifying performance and test requirements

Application of Council Directives:

- 2006/95/EC Low Voltage Directive
- 1992/31/EEC EMC Directive
- 1993/68/EEC EMC Directive amendments
- 2011/65/EU Hazardous substances in electrical and electronic equipment - RoHS

Year of CE marking: 2015-2016



The Standards mentioned above fulfil the requirements for CE marking

1.7 Warranty

Static Power operating through its authorised agents warrants that the standard products will be free of defects in materials and workmanship for a period of 24 months after the date of invoice, or such other period as may be specified.

Should you require guidance or if the unit does not operate correctly as expected we provide a help desk service. This can be attained by Email or telephone. If the unit is found faulty we will help to identify the cause and where necessary a replacement part will be provided or the unit can be returned for repair. On site services are not covered.

This warranty does not cover failures of the product which result from incorrect installation, misuse, alterations by persons other than authorized agents or abnormal operating conditions.

2. SYSTEM OVERVIEW & OPERATION

2.1 Description

A Static Transfer Switch (STS) provides seamless switching between two power sources to provide uninterrupted power to a critical load.

The iSTS continuously monitors the supply sources for failure or degeneration and switches automatically to the alternate source as required to protect the load against failure. The break in the supply transition is so short that it is not seen by the critical load. This switching process is undertaken as a break before make transfer, preventing overlapping which can cause large and unpredictable currents. In 4-pole models, all the active conductors and the neutral are switched. In 3-pole models, only the active phases are switched. Thyristors are used to undertake the switching process.

In the case of downstream load fault conditions, the fault current drawn from the supply may degrade or damage the supply sources; as a consequence should a fault current exist in the load the iSTS will inhibit a transfer to the alternate source even if this causes source supply degradation or loss. This is to ensure that the fault will not be transferred to the alternate supply with the possibility of degrading both sources. The current threshold for isolation is pre-set to approx. 300% of the rated current.

This unit contains fuses. The fuses are to provide for safe operation even in high fault capacity environments. It should be noted that the fuses are for the protection of the semiconductor switches (SCRs/ Thyristors), not the load. The iSTS does not have any automatic tripping devices, so load discrimination is undertaken in the primary and secondary supply networks.

2.2 Overview

The iSTS is housed in a wall mounted IP54 rated enclosure. Repair is achieved in conjunction with the Maintenance Bypass Switch located at the bottom of the iSTS.

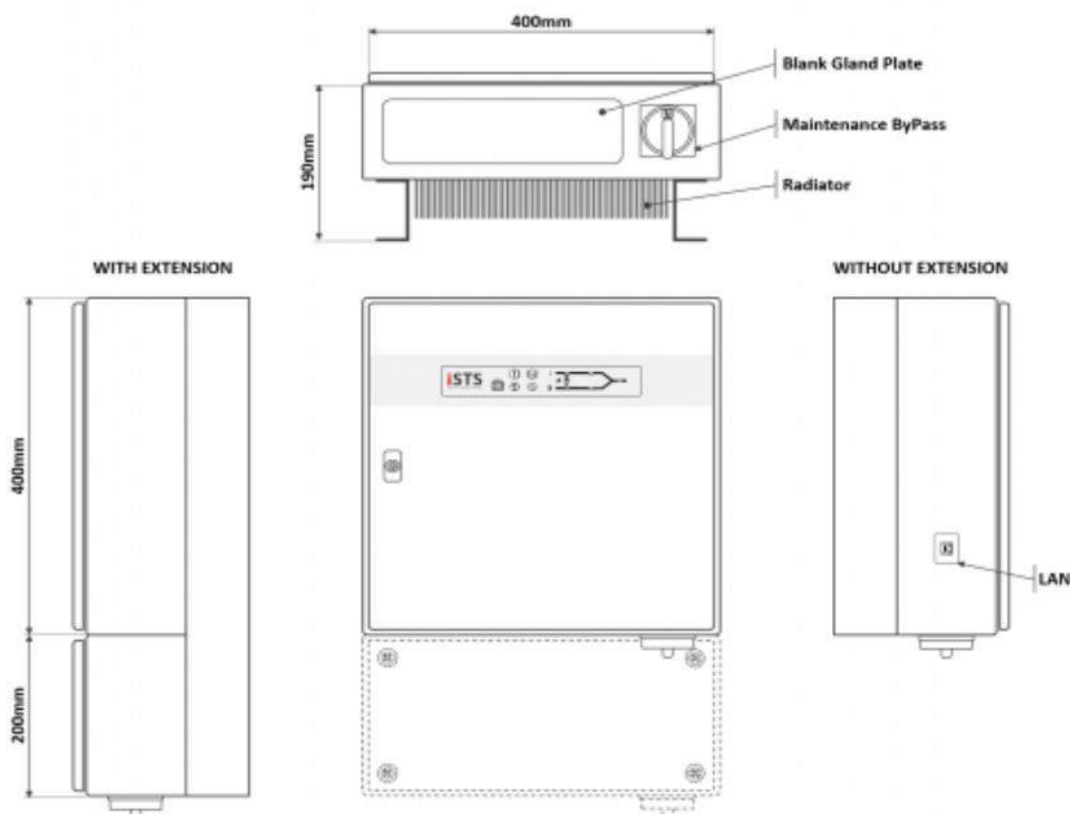

2.3 Operational Parameters

Absolute Maximum Values	Min	Max
Input Voltage	100 V _{AC}	264 V _{AC}
Load Current	0A	32A
Input Synchronisation	-180°	+180°
Ambient Temperature	0°C	55°C

Recommended Values	Min	Max
Input Voltage	104/208 V _{AC}	126/265V _{AC}
Load Current	0.5A*	0 – 32A
Input Synchronisation	-15°	+15°
Ambient Temperature	0°C	45°C

*Due to the nature of the silicone controlled rectifiers used in all static transfer switches, some current must be applied to the iSTS to ensure a clean break during transfers.

Overload Capacity @45°C	Time
200%	30s
300%	1s
400%	0.1s
2000A	1 cycle

2.4 Line Diagram: Single phase/2-Poles

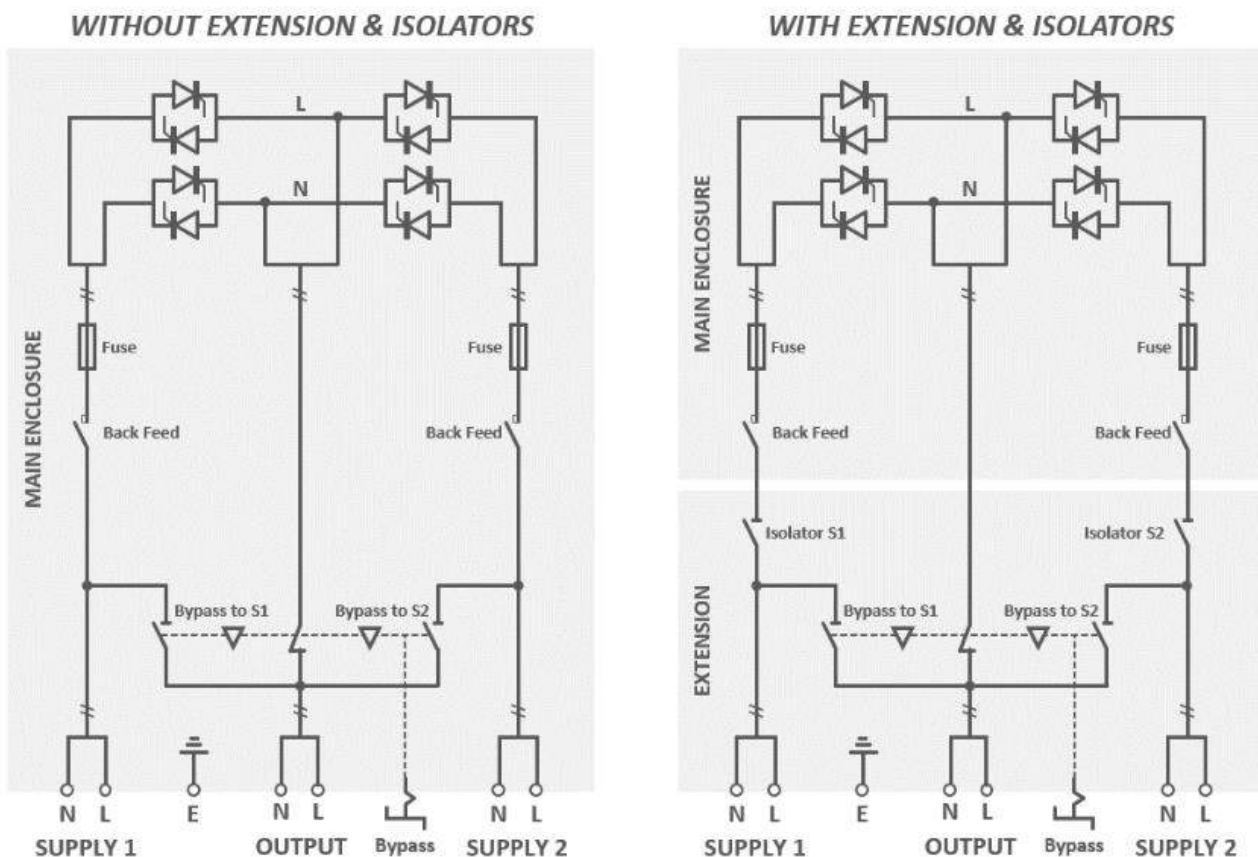

3. OPERATION

3.1 Safety

The iSTS is powered from two separate sources. It is important that you install correct signage with procedures within the enclosure and the immediate vicinity to warn personnel of this aspect and what isolation, checking and precautionary processes, and procedures need to be adopted to make the iSTS and equipment connected to the iSTS safe to work on.

This equipment receives power from more than one source. Disconnect output and all input sources of power from this equipment before servicing.

Do not proceed with the installation or operation of the iSTS if it has been damaged. Carefully inspect the iSTS for any damage that may have occurred during shipping, unpacking or during and after any installation process.

Take care when handling the iSTS and ensure that it is physically supported during the installation process. At the end of the installation process the iSTS should be firmly and securely bolted within the rack.

Ensure the cables are securely connected and supported and all covers plates are replaced. There should be NO live exposed or accessible contacts that could cause electrical shock if contact is able to be made. This unit is designed for fixed wiring installation only.

This equipment is not recommended for installation into environments that utilise RCD earth leakage detectors on the inputs of the static transfer switch. Consult Static Power for special considerations.

**EARTH CONNECTION IS ESSENTIAL BEFORE WORKING ON CIRCUITS
OR CONNECTING / DISCONNECTING SUPPLIES.**

TREAT AC INCOMING LEADS AS LIVE IF DISCONNECTING FROM SOURCE.

3.2 Installation

1. Secure the iSTS to your wall / enclosure / frame using the channel holes with Hex bolts on the rear mounting rails of the STS. Use the two bottom holes to further secure the STS.

3.3 Cable Termination to the iSTS

1. Attach cables using bolted lug connections to the terminals in the order show below. The terminals have a M6/M8 screw

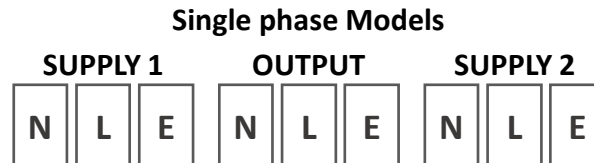

2. To access the input and output terminals open the door of the enclosure and remove the terminal cover /GAL plate from the front of the unit. Cables enter from the bottom. Remove the gland plate and make holes suitable for glands.
3. Connect Active, Neutral and Earth cables to the respective terminals as marked at the terminals. Secure the connections on the terminal blocks, torque the screw to 25Nm / 20in-lbs. All cables connecting to the STS should be supported by the gland and not strain the point of connection.
4. All electrical connections are to be realized by properly qualified, skilled and competent service personnel only.
5. Before replacing the GAL protective cover check all connections and that all ribbon cables are plugged in and secure. That nothing has moved out of place during handling and transport. Check all screw connections.
6. Before applying power replace all of the GAL panels removed prior, close the door. Check the ratings of all sources and cables to the iSTS, make sure that the rated voltage for the unit corresponds to the ratings plate and the local supply voltage.
7. Turn the maintenance bypass switch to the bypass position (either to S1 or S2). Close the incoming source isolators. (Note the two incoming source isolators provide power to the solid-state portion of the STS only. The load will be powered via the maintenance bypass switch.
8. Apply power to the STS. There will be a short 15 second start-up period, after which the iSTS LED mimic will show the direction of power flow.
9. Ensure that the LEDs (Green), that show which source is supplying the load is the same as the Maintenance Bypass Position. If not use the transfer/ priority selection to transfer to the alternate supply (same as maintenance bypass position).
10. Proceed to section 3.5 Start-up to connect the STS to the load from Maintenance Bypass.

When working on live iSTS, be sure to comply with the applicable national standards and accident prevention rules.

3.4 Synchronism

The smoothest change-over occurs when the supplies are in synchronism, so it is best to make sure the input supplies are in synchronism. Some equipment (like transformers and other items) may saturate when a transfer occurs when not in synchronism. This causes large currents to flow into the load which could cause damage to the transformer, trip protective devices or blow fuses.

The iSTS is configured to optimize the transfers.

3.5 Start-up

NOTE: Due to the nature of SCRs (silicon controlled rectifiers) some load of around 0.5A is required for correct operation. Before testing the operation of this iSTS, make sure this load is applied to the output.

1. Ensure that your two input sources are within the tolerances and in synchronism.
2. If not already done, apply power to both input sources. There will be a short 15 second start-up period, after which the iSTS will begin powering your load.
3. Once power availability has been confirmed slowly rotate the STS maintenance bypass switch to the N (Normal) position
4. We recommend at this point that you connect to the STS using a laptop computer. Open up a browser and make connection via the LAN. We strongly encourage the setting of the date and time so that real time event correlation can be undertaken. The Real Time Clock is backed up by a rechargeable coin cell battery. If the battery is flat at the time of commissioning it may take several days to re-charge.
5. The ALARM should not be active. If it is check the following conditions that may be active:
 - ON Supply 1 when priority is Supply 2
 - ON Supply 2 when priority is Supply 1
 - Supply 1 or Supply 2 are not in spec
 - Override Switch is in position 1 or 2
 - Supply 1 & 2 are not in synchronism
 - The unit is too hot (thermal bi-metal switch on H.S. activated)
 - There is / was an overcurrent/ overload / load fault condition

4. USER INTERFACE

4.1 Mimic Display

The mimic utilizes bi-colour LEDs to indicate the direction of power flow and the availability/status of power.

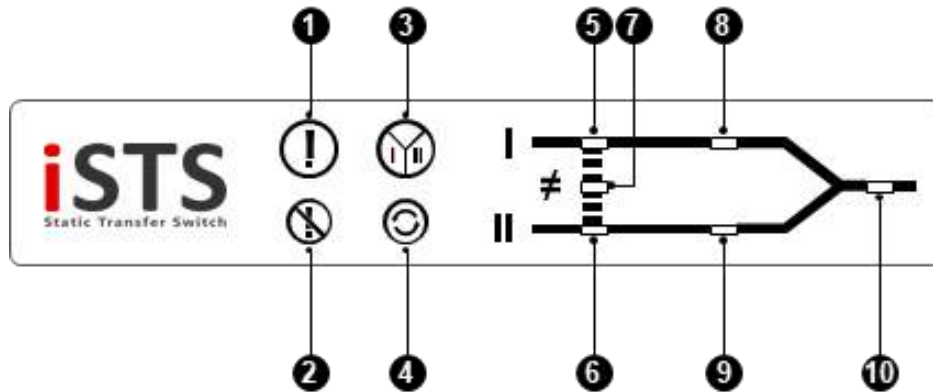

Name	Normal	Alarm	Other
1 SUMMARY ALARM LED	Not Lit	Flashing Alarm is Active	Press ALARM CANCEL if alarm still active then will be LIT solid (Not flashing)
2 ALARM CANCEL PUSHBUTTON	Not used	Press to acknowledge Alarm	if alarm still active then will be LIT solid (Not flashing)
3 PREFERRED SUPPLY SELECTION INDICATOR LED	In centre then No Priority is set	When TRANSFER pushbutton is pressed each time cycles through I, preferred, II preferred and no preferred	Once released on I or II the unit will transfer to I or II if not already on I or II
4 TRANSFER AND PREFERRED SUPPLY SELECTION PUSHBUTTON	Press to transfer	-	STS transfers to preferred selected supply after release of pushbutton

Name	GREEN	RED	Normal State
5 SUPPLY 1 OK LED	Supply 1 is within tolerance	Supply 1 is out of tolerance	GREEN if Supply 1 is ON
6 SUPPLY 2 OK LED	Supply 2 is within tolerance	Supply 2 is out of tolerance	GREEN if Supply 2 is ON
7 SYNC OK LED	Supply 1 and Supply 2 are within synchronisation range to perform a transparent transfer	Supply 1 and Supply 2 are not within synchronisation range to perform a transparent transfer	GREEN when Supply 1 and Supply 2 are both ON
8 ON SUPPLY 1 LED	Load is on Supply 1	Load is not on Supply 1	GREEN if load is Supply 1
9 ON SUPPLY 2 LED	Load is on Supply 2	Load is not on Supply 2	GREEN if load is Supply 2
10 iSTS OUTPUT LED	Output is OK	Output is faulty	GREEN

4.2 User Interface Terminations

The User remote General Alarm terminal is located behind the door of the enclosure. If it is to be used a gland should be fitted at the bottom of the enclosure. Similarly access to the LAN (if optional) can be similarly gained. Ideally keep good separation between the power conductors and the remote contact wiring.

The relays can switch up to 50VAC/DC - 2A and are not suitable for 110/240V or other applied voltages

4.3 Preferred Switch

This switch allows the preferred source to be set to Supply 1, Supply 2 or None (0), which will take affect only when the preferred source is set to None (0) on the iSTS software. Refer to the Web Interface section for instructions on changing the preferred source through LAN connectivity.

If the iSTS has transferred the critical load to the alternate source, the iSTS will automatically transfer back to the preferred again when the preferred source is within tolerance and after a pre-set settling delay, typically 4 seconds.

4.6 Confirm Operation

1. Press the Preferred Button to highlight 'I' on the Preferred Indicator. Wait for the STS to transfer to Supply 1, if is not already on Supply 1. On Supply 1 LED will turn green.
2. Turn off Supply 1. Confirm that the STS transfers to Supply 2. On Supply 2 LED will turn green.
3. Turn on Supply 1. Confirm that the STS automatically transfers to Supply 1 after a 3 second delay. On Supply 1 LED will turn green.
4. Press the Preferred Button to highlight 'II' on the Preferred Indicator. Wait for the STS to transfer to Supply 2. On Supply 2 LED will turn green.
5. Turn off Supply 2. Confirm that the STS transfers to Supply 1. On Supply 1 LED will turn green.
6. Turn on Supply 2. Confirm that the STS automatically transfers to Supply 2 after a 3 second delay. On Supply 1 LED will turn green.
7. The operational test is complete. You can now select a preferred supply if any.

5. MAINTENANCE BYPASS

5.1 Overview

Maintenance Bypass mode allows the load to be connected to one supply without going through the power circuit of the STS.

The maintenance bypass switch is located on the front of the power module. The switch is normally in the “N” position and can be used to bypass the internals of the STS to either “Supply Source 1” or “Supply Source 2”.

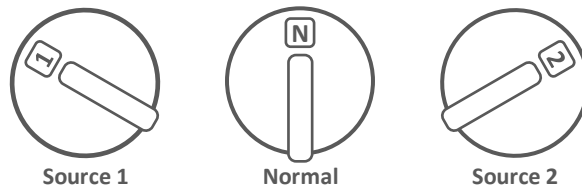

THE MAINTENANCE BYPASS SWITCH SHOULD ONLY BE USED TO SELECT THE PRESENTLY OPERATING SOURCE. IT CANNOT BE USED TO TRANSFER THE CRITICAL LOAD FROM ONE SOURCE TO THE OTHER.

The maintenance bypass switch utilises make-before-break switching, incorrect operation of the maintenance bypass features could result in dangerous voltages occurring and short circuits.

Note: A padlock can be used to stop inadvertent or unauthorized operation of the switch.

5.2 Maintenance Bypass Procedure

Bypass Mode on Supply 1

1. Use the TRANSFER pushbutton on the front of the unit to transfer the load to Supply 1.
2. TURN OFF Supply 2 using the isolator switch on the front of the unit.
3. Finally operate the Maintenance Bypass Switch by turning to position 1. The unit will now be in bypass mode on Supply 1.

Bypass Mode on Supply 2

1. Use the TRANSFER pushbutton on the front of the unit to transfer the load to Supply 2.
2. TURN OFF Supply 1 using the isolator switch on the front of the unit.
3. Finally operate the Maintenance Bypass by turning to position 2. The unit will now be in bypass mode on Supply 2.

Testing the iSTS

Once the unit is in maintenance bypass mode on either Supply 1 or 2, the unit can be tested as the output of the solid-state switch is disconnected by the maintenance bypass switch. To service the switch and before removing the internal Gal panel turn-off the isolators on the terminal enclosure and remove the control fuses. This will not affect power flow to the load when in maintenance bypass.

5.3 Reinstatement from Maintenance Bypass

1. Turn on both Supply 1 and Supply 2 circuit breakers located at the front lower terminal section of the unit. Wait for the unit to start up. The mimic on the display screen should show Supply 1 and 2 as GREEN to indicate that both supplies are active in the STS.
2. Move or operate the Preferred Source selection switch to the supply that is in bypass.
3. Check the mimic LEDs and ensure that the STS and the maintenance bypass are the same (e.g. if Maintenance Bypass is at position 1 then the STS portion powering the load should have 1 Green)
4. Finally operate the bypass switch, returning it to the middle position.
5. The unit will now be normal operation mode.

6. WEB BROWSER INTERFACE- LAN

6.1 Home Page

Connecting to the LAN interface can be done two different ways with a RJ45 Cat5 Ethernet cable:

- To a Network hub/switch using a straight-through cable.
- To a PC using a cross-over cable (most PCs can now work with a straight-through cable).

To Access the Web Browser Interface

Once the iSTS is running and has been connected to your network open a browser and navigate to 192.168.1.2. If you are having trouble connecting to the STS try pinging the device. You will need to make sure that you are on the same subnet (192.168.1.XX).

Supply 1 Online
No Supply Preference

Variables

	L1	L2	L3
Supply 1(V)	224	226	229
Supply 2(V)	226	224	229
Output:			
Voltage	226	197	227
Current(A)	24	22	25
Power(kVa x10)	56	45	57
Power(kW x10)	55	44	56
Power Factor	0.98	0.98	0.98

Events

<<
<
>
>>
⌵

Date	Time	Event	Target
16/04/2018	15:51:04	S3 Average V	OK
16/04/2018	15:51:04	S3 Average V	OK
16/04/2018	15:51:04	S3 Average V	OK
16/04/2018	15:51:04	Transfer	1
16/04/2018	15:50:59	S3 Average V	L3
16/04/2018	15:50:59	S3 Average V	L2
16/04/2018	15:50:59	S3 Average V	L1
16/04/2018	15:50:59	Initialise	

Open Control Panel

The home page displays the connected supply, supply preference, variables and events list that can be scrolled through using the arrows provided. From the home page, gain access to the Control panel by clicking Open Control Panel and enter following username and password:

Username: **admin**

Password: **1234**

6.2 Control Panel

On the Control Panel page, many more options become available:

- Viewing utilisation
- Ability to transfer supply
- Setting the preferred supply
- Setting the name and location information
- Adjusting the time and date
- Setting the IP address

NOTE: You must press update for the information to be saved on the device

Control **Email**

Transfer Supply

Unit Details
Name:
Location:
Update

Network
DHCP: ON OFF
IP:
Subnet:
Gateway:
DNS:
Update

NTP
Address:
Timezone:
Time:
Date:
Update

6.3 Email

The Email tab allows you to turn on the email notification service. When a certain event occurs the unit will send an email to notify the user. The email takes the following format:

STS01 – LVL5
Supply 1 Fault - 05/05/2014 13:01:42

Server Settings

This is the SMTP server that the unit will use to send the email. You need to provide the Server Address, Server Port, User name or email, and a password.

Note: this cannot be an SSL SMTP server.

Control **Email** **Settings**

Email Notifications
 ON OFF **Set**

Settings
Server Address:
Server Port:
User name / Email:
Password:
Recipient Email:
Save

Email List
 Input/Output Faults
 Frequency and Synchronisation
 Preferred Supply Change
 Bypass
 Heat Warnings
 Transfer Inhibit
 Load/Current Warnings
 Force/Override
 User Transfers Warnings
 SCR/Thyristor
 Power Supply Faults
 Breaker Changes
Set

7.1 Fault Codes

Event	Append	Description	STS Action Resulting
INIT		RAM CHKsum failed – Cold Start (RAM Corrupt) – Flash Defaults downloaded	None - Contact Static Power
WARM BOOT		Power-up, Warm Start, re-initialize all but RAM – Keeps Event List	Normal After Black Start
SYNC	FLT/OK/WRN	S1 & S2 not in synchronism	Alarm No action
SUPPLY 1	FLT/OK	Supply 1 has a fault or fault has cleared	When fault is detected transfers to supply 2 if on 1
SUPPLY 1 TRANS		Supply 1 has Transient High or Low (1 sec)	Transfers to supply 2 if on 1
SUPPLY 1 AVG	LOW/HIGH/OK	Supply 1 steady state is outside tolerance limits	When fault is detected, transfers to supply 2 if on 1
SUPPLY 2	FLT/OK	Supply 2 has a fault or fault has cleared	When fault is detected transfers to supply 1 if on 2
SUPPLY 2 TRANS		Supply 2 has Transient High or Low (1 sec)	Transfers to supply 1 if on 2
SUPPLY 2 AVG	LOW/HIGH/OK	Supply 2 steady state is outside tolerance limits	When fault is detected, transfers to supply 2 if on 1
SUPPLY 3 AVG		Output steady state is outside tolerance limits	Transfers to inactive supply
SUPPLY 3 TRANS		Outside has Transient High or Low (1 sec)	Transfers to inactive supply
CURRENT	WARN/HIGH	Output is overloaded (timed shutdown)	Alarm No action starts timer
TRANSFER	1/2	Transfer to Supply 1 or 2 requested	User - Manual Action
PREF	1/2/OFF	Preferred Source Set 1, 2 or none	User - Manual Switch Only
SCR SC	1/2	SCR on S1 or S2 short circuit detected on Supply 1 or 2	Contact Static Power – Locks to safe source
SCR OC	1/2	SCR on S1 or S2 Open circuit detected on phase #	Contact Static Power – Locks to safe source

7.2 Load Fault

In case of sustained high current output load faults, the iSTS will inhibit a transfer to the alternate supply even if this means degradation or loss of source supply. It is therefore imperative that you ensure that the discrimination with downstream and upstream protective devices ensures that the downstream protective device always clears the fault first.

In case that all output is lost the faulty equipment should be located and removed from the iSTS output before re-instatement of power.

If the unit is inoperable then it should be returned to the manufacturer for repair or replacement.

8. RECOMMENDED MAINTENANCE SCHEDULE

If the unit is faulty then it should be removed from service as per the accompanying procedure and a qualified experienced service agent should affect repair.

- Once per month record the operating variables and compare with the specifications and operating parameters to ensure that the unit is operating correctly.
- Check the Event History and correlate any recorded events since last observation with real occurrences. Report / investigate any suspicious entries.
- Inspect cable connections for overheating.

Contact Static Power for help with troubleshooting and parts replacement.

NOTE: The user should not undertake repair procedures or gain access to the internal of the equipment.

9. SPECIFICATIONS

Current rating	16A and 32A
Voltage rating	115V or 230V, $\pm 10\%$ (as specified)
Type	1-Phase/2-Pole
Frequency	50Hz and 60Hz, $\pm 10\%$ - Auto detection
Transfer type	Break-Before-Make zero current transfer by Thyristors / SCR
Max break time	Less than $\frac{1}{2}$ cycle
MTBF	>1,000,000 hours
Maintenance bypass	None
Isolation	Incoming source isolator switches, front mounted, behind door
Display	Bi-colour LED mimic decal
Interface	Preferred supply selection, Source transfer selection and Alarm cancel button
Contact	One voltage free general alarm indicator, Form A or Form B - SPST
Ethernet	LAN optional
Input Connection	Bottom Cable Entry 6mm ² terminals via glands
Output Connection	Bottom Cable Entry 6mm ² terminals via glands
Dimensions H x W x D	400 x 400 x 190 mm
Weight	17 kg
Temperature	0 – 55°C
IP rating	IP54
Detection	Digital: <1ms
Loading	0 - 100% @ 55°C ambient
Device ratings	250 A _{RMS} , 1600V, 2kA for 1 cycle
Overload @40°C ambient	63A for 30s 100A for 1s 128A for 0.1s 2kA for 1 cycle
Fault current setting	300% peak with load fault transfer inhibit
Safe install environment	20kA, 100A internally fused
Protection	100A fuses - BS88/FE100
Power factor	No practical limit
Max THDV	10% - Max allowable source voltage distortion
Crest factor	3 : 1
dV/dt max	1000V/ μ s
Cooling	Passive
Humidity @55°C ambient	5 – 95% non-condensing
Regulatory approvals	IEC 62310-1,2,3 - IEC 60950 - IEC 61000-6-1,2,3,4 – CE – RCM - RoHS
Standard warranty	24 months offsite repair or part replacement

Specifications are subject to change without notice