

COOLX[®]1000

FANLESS, INTELLIGENT 1000 W MODULAR POWER SUPPLIES



Advanced Energy's CoolX[®]1000 series, part of our low voltage solutions, is the world's only fanless 1000 W modular power supply. Packaged in a compact 254 mm x 165.1 mm x 39.1 (10 in x 6.5 in x 1U) U-channel design, the CoolX1000 provides up to 1000 W without any requirement for fan or base plate cooling, eliminating acoustic noise detrimental to scientific and medical applications, as well as applications sensitive to vibration or where fan cooling is not available. The CoolX1000 also offers increased flexibility by allowing system designers to monitor and control power supply performance — essential for staving off process disruption — using either analog or digital communications (PMBus[™]).

PRODUCT HIGHLIGHTS

No Fan Featured

- 1000 W with 100% natural convection cooling
- No base plate needed
- No acoustic noise or vibrations

Reliability

- MTBF > 2,900,000 hours
- High-input surge protection — 4 kV line to PE for harsh environments
- Reverse energy protection — no blocking diodes required
- 24 W standby power
- Safety approved to 5000 m altitude
- 93% efficiency
- Five-year warranty

Flexibility

- Analog and digital management — PMBus[™] monitoring and control capability

- Field-configurable — plug and play power
- Series and parallel outputs — higher voltages/currents
- Mounting options — base/side and DIN-Rail mounting

TYPICAL APPLICATIONS

Medical

- Clinical diagnostic equipment, medical lasers, dialysis equipment, radiological imaging, chemical chemistry

Industrial

- Test and measurement, industrial machines, automation equipment, printing, telecommunications, audio equipment

Hi Rel

- Harsh industrial electronics, radar (naval- and ground-based), communications, test and measurement

AT A GLANCE

CX10S CX10M

Power

1000 W 1000 W

Slots

6 6

Cooling

No fan featured

Parameters

254 mm x 165.1 mm x 39.1
(10 in x 6.5 in x 1U)

Certifications

Medical

- IEC60601-1 3rd edition, IEC60601-1-2 4th edition (EMC)
- 2 MOPP
- Dual fused

Industrial

- IEC60950, IEC62368-1
- ISO 9001:2015

Defense/Aero

- MIL-STD-810G

MODULES

CoolX CoolMods				
Single Output Modules (1 Slot)	Vnom (V)	Set Point Adjust Range (V)	I _{max} (A)	Power (W)
CmA	5	2.5-6.0	21.0	105
CmB ¹	12	6.0-15.0 ²	15.0	180
CmC	24	15.0-28.0	8.3	200
CmD	48	28.0-58.0 ³	4.17	200
High Power Modules (3 Slot)				
CmE ⁴	24	24-25.2	25.0	600
CmF ⁴	48	48-50.4	12.50	600
Dual Output Modules (1 Slot)				
CmG ⁵ V1	24	3.0-30.0	3.0	90
V2	24	3.0-30.0	3.0	90
CmH ⁶ V1	5	3.0-6.0	6.0	36
V2	24	3.0-30.0	3.0	90
Wide Trim Modules (1 Slot)				
CmA-W01	5	1.0-6.0	21	105
CmB-W01	12	1.0-15.0 ²	15	180
CmC-W01	24	2.0-28.0	8.33	200
CmD-W01	48	3.0-58.0 ³	4.17	200

¹ Full dynamic specifications may not be met at full load when output voltage is trimmed by above 13 V

² Max trim 14 V when used with high power module

³ Max trim 56 V when used with high power module

⁴ a) Only one high power module (CmE or CmF) can be used per CoolPac.

b) During load transients starting from 0% load on the High Power modules, other modules in the CoolPac may experience an output voltage dynamic during the load change. Contact applications support for details or support.

⁵ For the CmG module, the max combined power of both outputs is 120 W

⁶ For the CmH module, the max combined power of both outputs is 100 W

ELECTRICAL SPECIFICATIONS

Input					
Parameter	Conditions/Description	Min	Nom	Max	Units
Nominal Input Voltage Rangenn	Universal Input 47-440 Hz	100	—	240	VAC
AC Operating Input Range		85	—	264	VAC
Extended AC Operating Range	Maximum for 5 seconds	—	—	300	VAC
DC Input voltage range		120	—	300	VDC
Input Current	90 VAC @ 620 W	—	8.5	—	A
Inrush Current	230 VAC @ 1000 W	—	—	25	A
Power Factor	120 VAC @ 800 W	0.98	—	—	—
Undervoltage Lockout	Shutdown	65	—	74	VAC
Input Fuses Rating	Dual Fused (Line and Neutral) 250 VAC	—	10	—	A
Efficiency	230 VAC, 1000W with 5 x CmC CoolMods	—	92	—	%
	230VAC, 1000W with CmB/CmC/CmD/CmF combination		93		%

Output						
Parameter	Conditions/Description	Min	Nom	Max	Units	
Power Rating	CX10: See derating curves	—	—	1000	W	
Minimum Load		0	—	—	A	
Line Regulation	For $\pm 10\%$ change from nominal line	—	—	± 0.1	%	
	CmE, CmF, CmG, CmH	—	—	± 0.5	%	
Load and Cross Regulation	For 25% to 75% load change	—	—	± 0.2	%	
Transient Response	For 25% to 75% load change 0.5 A/ μ S: Voltage deviation	—	—	4 (4)	%	
	*CmE and CmF, figures in () settling time	—	—	500 (1000)	μ S	
Ripple and Noise	100 mV or 1.0% pk-pk. 20 MHz BW	—	—	1	%	
	CmE, CmF	—	—	1.5	%	
Overvoltage Protection	Tracking OVP Level (N/A in CmE and CmF, CmG, CmH)	105	—	125	%	
	Non-latching OVP	110	—	160	%	
Remote Sense	Max. line drop compensation. (N/A in CmG, CmH)	—	—	0.5	VDC	
Overshoot		—	—	1	%	
Rise Time	Monotonic CmG, CmH figures in ()	—	—	10 (20)	ms	
Turn-On Delay	From AC	—	—	800	ms	
	From global enable	—	—	12 (20)	ms	
	From CoolMod enable	—	—	12 (20)	ms	
Hold-Up Time	For nominal output voltages at full load	20	—	—	ms	
CoolMod Power	As per CoolMod table	—	—	—	—	
Output Adjustment Range	Manual: Multi-turn potentiometer. As per CoolMod table Vtrim: As per CoolMod table	—	—	—	—	
Overcurrent Protection	Straight line with hiccup activation @ 35% Vo nom CmE, CmF, CmG, CmH: Current limit hiccup autorecovery	110	130	150	%	
Short Circuit Protection	Yes, autorecovery	—	—	—	—	
OverTemperature Protection	Yes, autorecovery (CmG, CmH latch off)					
Capacitive Load	Nominal output voltages at full load	CmG	—	—	270	μ F
		CmH			270	μ F
		CmE			10	mF
		CmF			2.5	mF

ELECTRICAL SPECIFICATIONS (CONTINUED)

Auxiliary Output					
Parameter	Conditions/Description	Min	Nom	Max	Units
Auxiliary Output Voltage	Aux Voltage Option A	11.76	12	12.24	V
	Aux Voltage Option B	4.75	5	5.25	V
Load Regulation		—	—	±2	%
Line Regulation	For ±10% change from nominal line	—	—	±0.5	%
Maximum Output Current	Aux Voltage Option A	—	—	1.96	A
	Aux Voltage Option B	—	—	4.7	A
Maximum Output Capacitive Load		—	—	1000	uF
Output Overcurrent Protection	Hiccup	110	—	140	%
Short Circuit Protection	Yes, autorecovery	—	—	—	—

Galvanic Isolation					
Parameter	Conditions/Description	Min	Nom	Max	Units
Input to Output	Reinforced (2 x MOPP); contact Advanced Energy for Hi-Pot instructions	4000	—	—	VAC
Input to Case	Basic (1 x MOPP)	1850	—	—	VAC
Output to Case	Basic (1 x MOPP)	1850	—	—	VAC
Output to Output	Basic (1 x MOPP)	1850	—	—	VAC
Output to Output (Dual)	CmG, CmH V1-V2	500	—	—	VDC

Reliability					
Parameter	Conditions/Description	Min	Nom	Max	Units
Reliability and MTBF	MTBF of > 2,900 kHours, Telecordia SR-332, Issue 4 CoolPac	—	0.33	—	Fpmh
Warranty	5 years	—	—	—	—

ELECTRICAL SPECIFICATIONS (CONTINUED)

Environmental					
Parameter	Conditions/Description	Min	Nom	Max	Units
Operating Temperature	Operates to specification below -20°C after 10 min warm-up	-40	—	85	°C
Storage Temperature		-40	—	85	°C
Derating	See derating curves included in the CoolX1000 Designers Manual	—	—	—	—
Relative Humidity	Non-condensing	5	—	95	%RH
Shock and Vibration	MIL-STD-810G Method 514.6	—	—	—	—
Altitude		—	—	5000	m

EMC		
Parameter	Conditions/Description	Criteria
Radiated Emissions ¹	EN 55011, EN 55022 and FCC, Class B	Compliant
Conducted Emissions	EN 55011, EN 55022 and FCC, Class B	Compliant
Power Line Harmonics	EN 61000-3-2, Class A	Compliant
Voltage Flicker	EN 61000-3-3	Compliant
ESD	EN 61000-4-2, level 4, 8 kV contact, 15 kV air	A
Radiated Immunity	EN 61000-4-3, level 3, 10V/m 80-2700 MHz	A
Electrical Fast Transient	EN 61000-4-4, level 4, ±4 kV	A
Surge Immunity	EN 61000-4-5, level 4, 2 kV DM, 4 kV CM	A
Conducted RF Immunity	EN 61000-4-6, level 3, 10 Vemf 150 KHz-80 MHz	A
Power Frequency Magnetic Field	EN 61000-4-8, level 4, 30 A/m	A
Voltage Dips & Interruptions	EN 61000-4-11	A & B Compliant

¹ Consult AE applications for system level compliance

Standards & Directives	
Standard	Conditions/Description
Safety Agency Approvals	EN60601-1 3rd edition, UL60601-1, CSA601, EN60950 2nd edition, CSA C22.2 No. 60950-1
IEC/EN 60950-1, Edition 2 and All National Deviations	UL 60950-1/CSA 22.2 No 60950-1, Edition 2; 5000 m (16,400 ft) altitude, 100 V to 240 VAC ±10%
IEC/EN 60601-1, Edition 3 and All National Deviations	IEC 60601-1(2005), EN60601-1(2006), ANSI/AAMI ES 60601-1(2005), CAN/CSA C22.2 No. 60601-1 (2008); 5,000 m (16,400 ft) altitude, 100 V to 240 VAC ±10%
IEC 62368 Edition 2	IEC 62368-1 (2014) Edition 2 5000 m (16,400 ft) altitude, 100 V to 240 VAC ±10%
IEC 60601-1-2 Edition 4	IEC 60601-1-2 (2014)
Protection class	Class I
WEEE	Waste Electrical and Electronic Equipment Directive (WEEE) 2002/96/EC
ROHS	EU DIRECTIVE 2011/65/EC RoHS compliancy
REACH	Compliant

MECHANICAL SPECIFICATIONS

Mechanical Data		
Parameter	Description	
Dimensions (L x W x H)	L x W x H	254 mm x 165.1 mm x 39.1 (10 in x 6.5 in x 1U)
Weight	Nominal Weight: CoolPac + 6 x CoolMods	1 Kg
Connectors	Description	Mating Connectors (if applicable)
AC/DC Input Terminal Block	TE 2-1437667-S, DINKLE DT-35-B07W-03	—
Main DC Output Terminal Block (CmA-CmF)	M4 Screws	—
Main DC Output Terminal Block (CmG, CmH)	Camden - CTB9350/4A	—
Output Signal Connector (CmG, CmH)	Molex - 87833-0831	—
System Signal Connector J1007	Molex 87833-0831 8-way	Locking Molex 51110-0860; Non Locking Molex 51110-0850; Crimp Terminal: Molex p/n 50394 or Molex 51110-0856 which includes locking tab and polarization keying
Output Signal Connectors J1001-1006	Molex 87833-0631 6-way	Locking Molex 51110-0660; Non Locking Molex 51110-0650; Crimp Terminal: Molex p/n 50394 or Molex 51110-0656 which includes locking tab and polarization keying
Output Sense Connectors J3	JST-S2BPH-K(LF)(SN)	JST PHR2. Crimp Terminal JST BPH-002TP.0.5S or SPH-002T-P.05S
Auxiliary Output Connector J1	Molex 1041880210 2pin	—

CoolX Mechanical Drawings

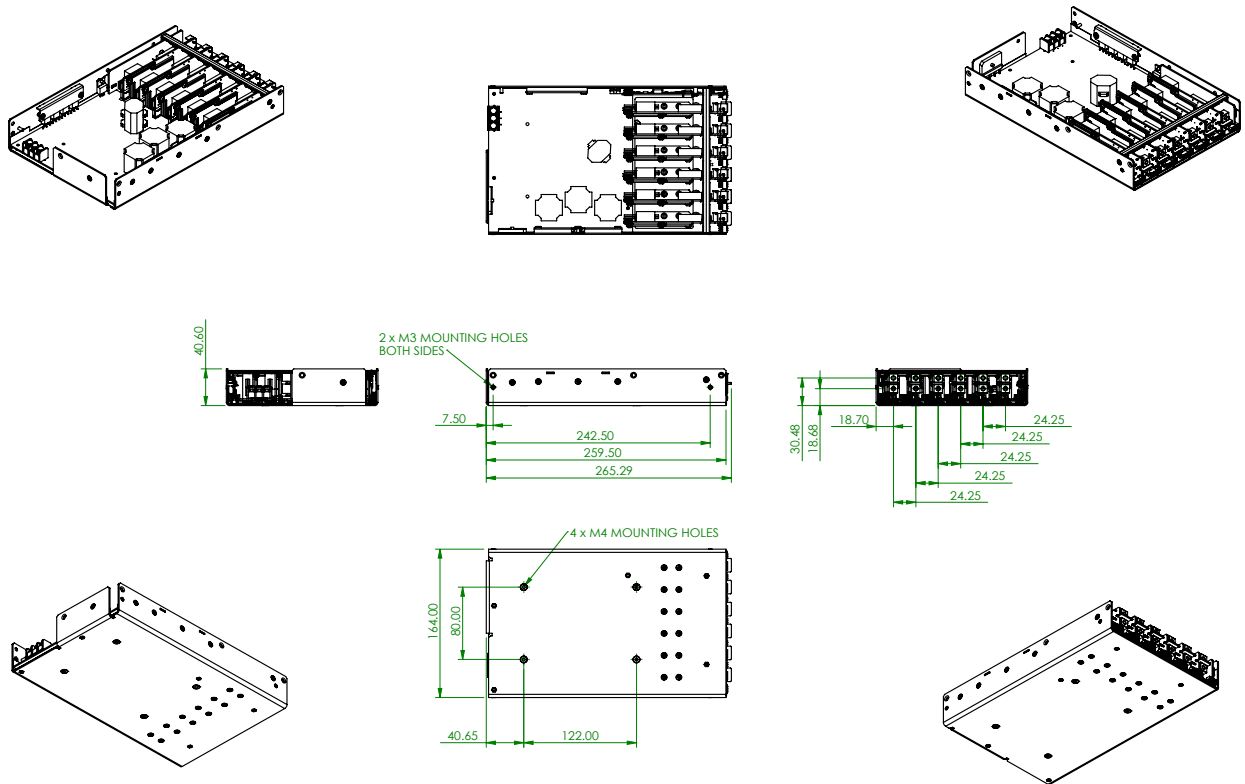

* Maximum screw penetration from base does not exceed 1.5mm.

CoolX can be mounted on its base, vertically or on its side. CoolX can also be mounted on the DIN Rail accessory (Z744).

EFFICIENCY AND DERATING CURVES

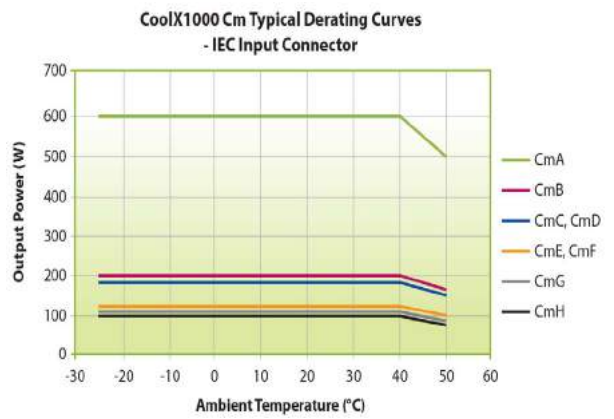
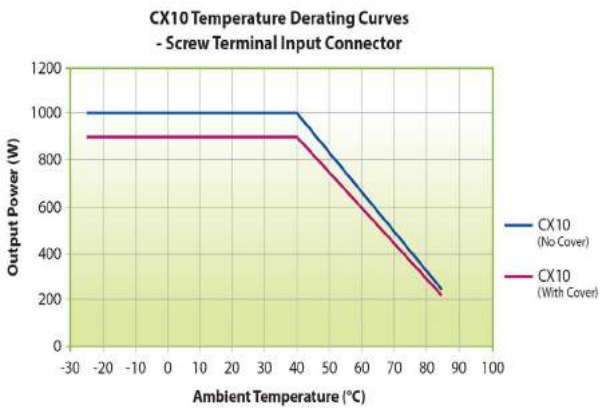
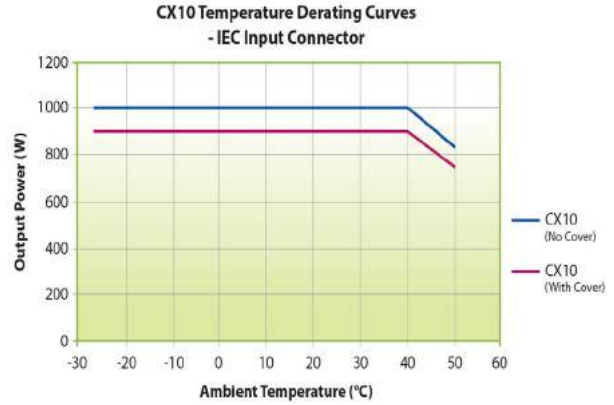
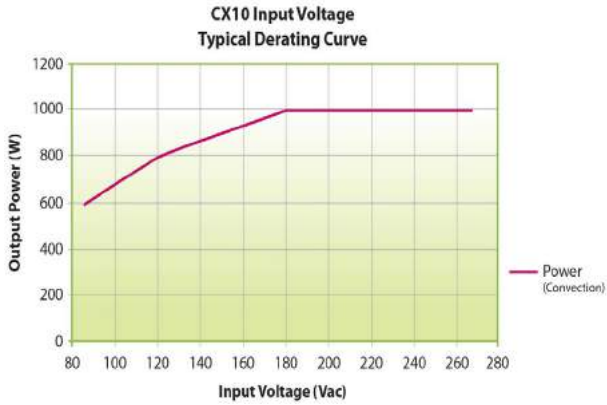

* Temperature and Derating curves based on CoolX1000 mounted on a 612mm x 612mm x 1.7mm conductive surface

INTERFACE

Input Connectors

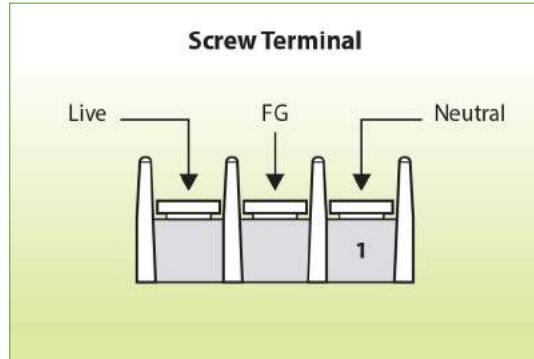

Standard (Screw Terminal)

CoolPac Connectors

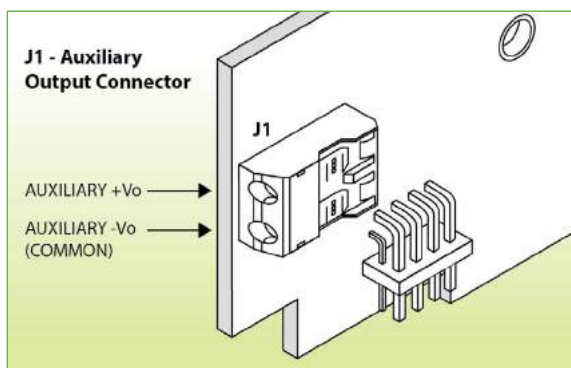
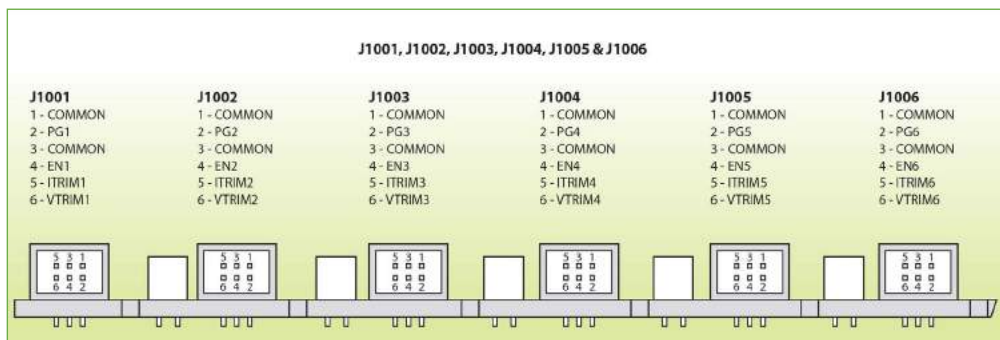
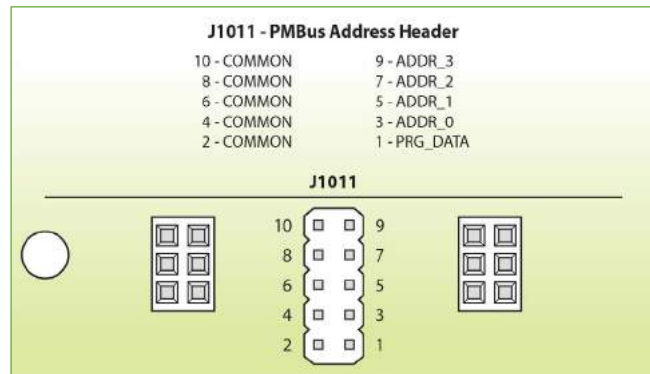
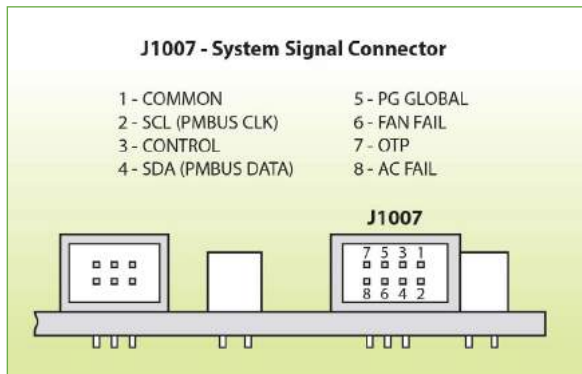

INTERFACE (CONTINUED)

CoolMod Connectors

Australia: sales@heliosps.com.au - Middle East & Asia: sales@heliosps.asia -New Zealand: sales@heliosps.co.nz

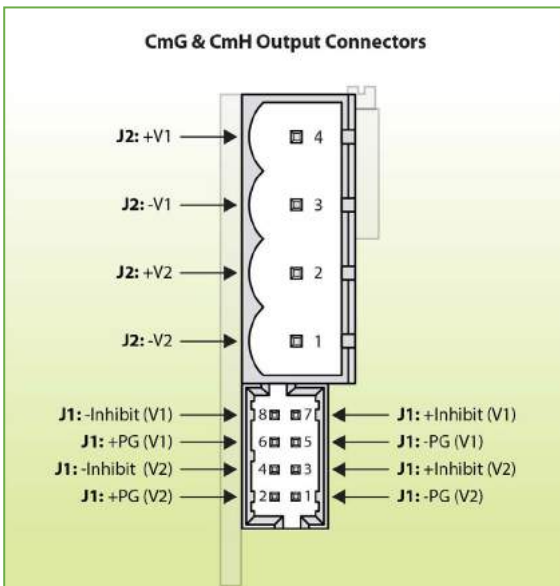
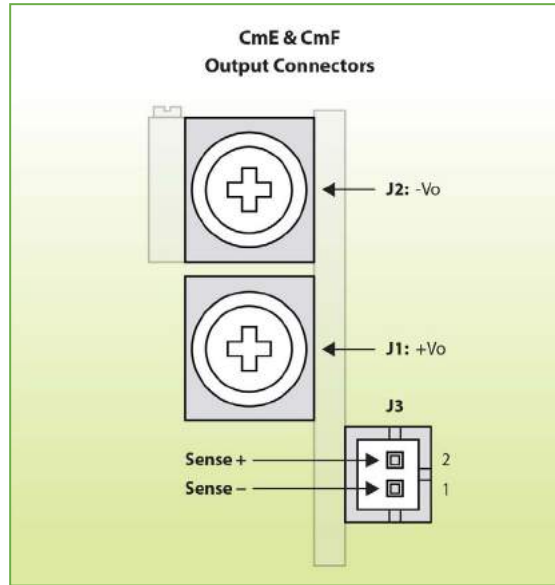
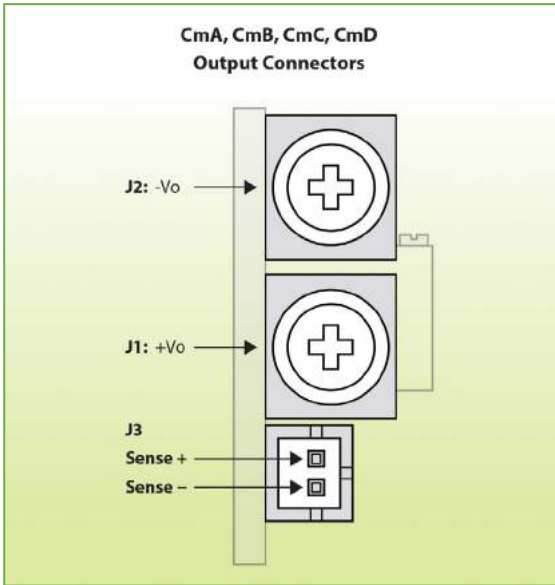

CONFIGURATION

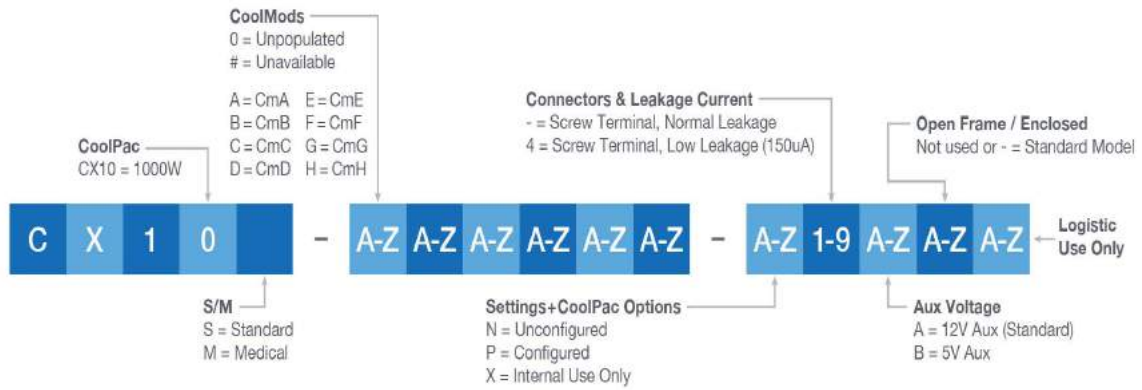

*CmE or CmF High Power Module (3 slot module) can only occupy Slots D/E/F.

Configuration Example 1

CoolX part number CX10S-ACD##E-N-A specifies the following product:
 CX10S—1000 W IEC60950 approved
 Slot 1: CmA, 5 V/21 A module
 Slot 2: CmC, 24 V/8.33 A module
 Slot 3: CmD, 48 V/4.17 A module
 Slot 4: Unusable because slot 6 contains a CmE module
 Slot 5: Unusable because slot 6 contains a CmE module
 Slot 6: CmE, 24 V/25 A module
 Option N: Nominal output voltage settings
 Option A 12V/1.95A bias supply voltage

Configuration Example 2

CoolX part number CX10M-ABCCDH-PB specifies the following product:
 CX10M—1000 W IEC60601-1 approved
 Slot 1: CmA, 5 V/21 A module
 Slot 2: CmB, 12 V/15 A module
 Slot 3: CmC, 24 V/8.33 A module
 Slot 4: CmC, 24 V/8.33 A module
 Slot 5: CmD, 48 V/4.17 A module
 Slot 6: CmH, 5 V/6 A and 24 V/3 A dual module
 Option P: Preset required. Slot 3 and Slot 4 connected in parallel.
 Option B: 5 V/4.7A bias supply voltage