

ENERSINE™ APF

THE NEW GENERATION OF COMPACT ACTIVE FILTERS FOR HARMONICS & REACTIVE CURRENT COMPENSATION

■ ESP34W APF



Benefits

- ☑ Real-time compensation from 2nd to 51st order.
- ☑ Improve leading and lagging Power Factor.
- ☑ Provide load balancing without rewiring of existing loads.
- ☑ Significantly reduce the voltage waveform distortion.
- ☑ Reduce voltage drop and temperature rise on transformers & cables.

Features

- High Density and Scalable System Architecture.
- Universal Voltage: 208V/400V/480V (without transformer).
- Harmonic compensation for 3-wire or 4-wire system selectable.
- Close/Open Loop Selectable Control.
- Ultra-fast response to load changes within 1 microseconds.
- Same or Different rated current filter system can wired in Parallel with common coupling CT.
- Suitable with 1 Amp or 5 Amps CT Secondary Current.
- 7inch Touch screen HMI provides power parameters and display data in tables and waveforms.

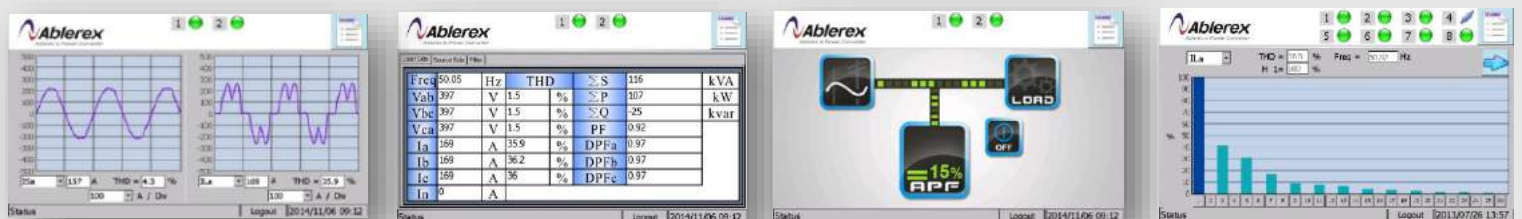

ENERSINE™ APF

THE NEW GENERATION OF COMPACT ACTIVE FILTERS FOR HARMONICS & REACTIVE CURRENT COMPENSATION

Operating Principle

Enersine™ APF measures and monitors the entire load current through external auxiliary coupling current sensing transformers (CT) mounted on the AC line, removes the fundamental frequency component and injects opposite phase harmonic current to cancel harmonic current in the electrical distribution system.

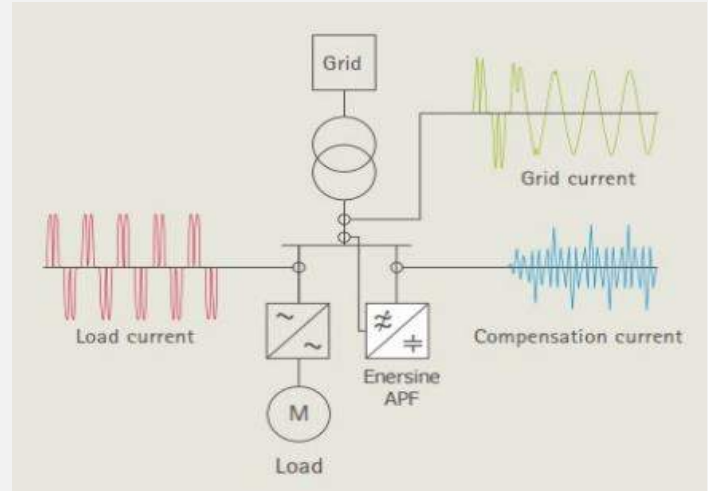

Numerous Correction Options

External auxiliary coupling current sensing transformers (CT) are the essential components in all active filter applications and generally all Active Filters are classified as source sensing or load sensing types depending on the point of coupling of the auxiliary CT.

Enersine™ APF is designed to have selective CT sensing configurations and numerous connection options. Different rated current of Enersine™ APF can be wired in parallel while connecting to the common external auxiliary coupling CT.

SOURCE SENSING (Close Loop)

Source-sensing require the external auxiliary CT to be coupled at the input supply source common to both the active harmonic filter and the harmonic generating equipment.

LOAD SENSING (Open Loop)

Load-sensing require the external auxiliary CT to be located nearest to the point of common coupling in the direction of the harmonic generating equipment.

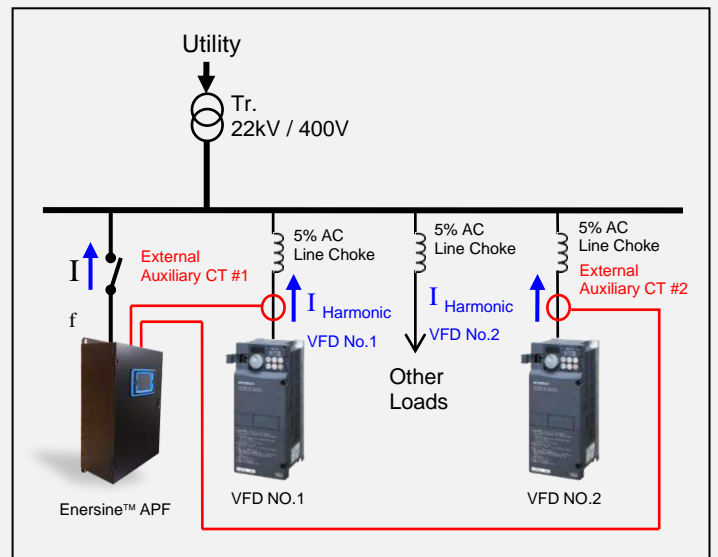
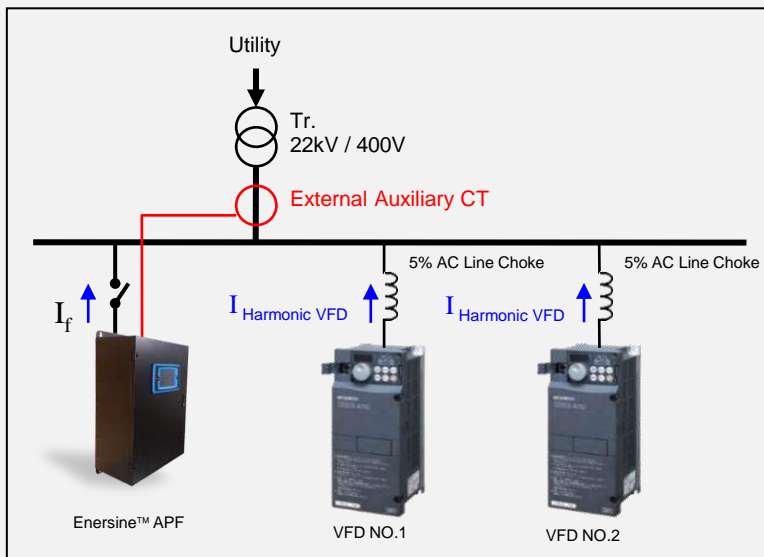

Compact & Extendable Architecture

Space-saving high density wall-mount design

Like all Enersine™ APF series, the compensation power electronics are packed in compact enclosed modules with forced air cooling designed for wall-mount installations where space is at a premium and harmonic mitigation current is high.

These ESP-34W power modules (PM) each 35A_{RMS}, 60A_{RMS}, 80A_{RM}, 90A_{RM}, 100A_{RMS} rated and extendable, can be easily installed in small and confined areas, as well as the required “out of reach” locations.

Each power modules is fully HMI integrated with built-in controller is capable of compensating harmonics and phase displacements independently. Remote monitoring using Building Management System (BMS) via Modbus over RS485 RTU or Ethernet interface is available. Commissioning and maintenance can be easily performed with a laptop and Ethernet port.

High density design allow these modules to connect in parallel to achieve higher compensation power.

Intuitive Human Machine Interface

The Enersine™ APF is equip with an intuitive Human Machine Interface (HMI), including a 7inch Coloured LCD Touch Screen with direct access and control of APF parameters, status and waveforms for management of both APF and system power quality.

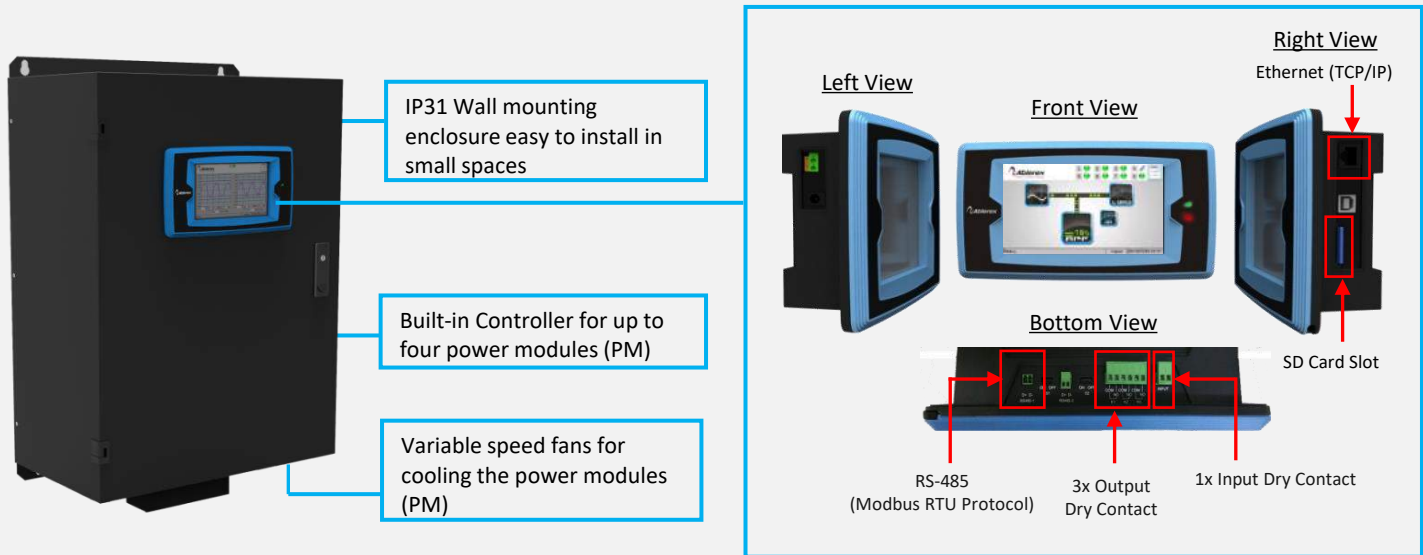

Parallel Capabilities

Connect in parallel to achieve higher Rated Current

Featuring a nominal compensation of 90A_{RMS} and 100A_{RMS}, higher compensation power can be easily attained by paralleling additional power modules (PMs).

This is particularly useful when considering future expansion or changes to the electrical networks which increases harmonics levels and requiring greater harmonic mitigation current.

- Easy parallel up to 8 wall mounted power modules per system.
- Rated current can be extended up to 800A Filter Systems.
- 3-Level IGBT DSP control with Low losses.
- Dynamic compensation of reactive power, harmonics, and flicker, as well as load balancing in one system.

Parallel up to 8 units of 100A modules to achieve 800A

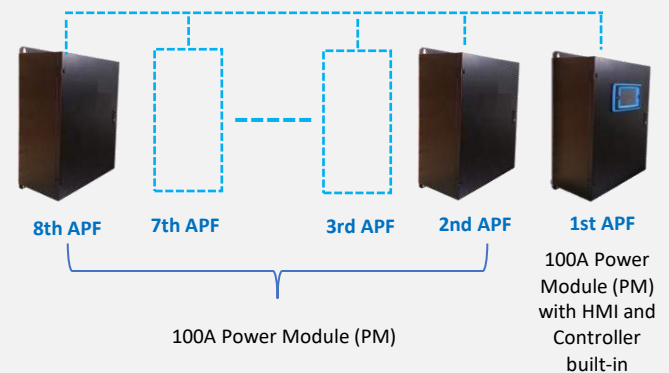

Specification

Model	ESP34W-35	ESP34W-60	ESP34W-80	ESP34W-90	ESP34W-100
Maximum Compensating Current Per Phase ¹	35A _{RMS} (per power module)	60A _{RMS} (per power module)	80A _{RMS} (per power module)	90A _{RMS} (per power module)	100A _{RMS} (per power module)
Maximum Neutral Compensating Current	3 times of Phase Current (400V version only)				
Maximum Scalable Current Per Phase	35A _{RMS}	480A _{RMS}	640A _{RMS}	720A _{RMS}	800A _{RMS}
Input Voltage Range	(i) 400V +15%, -20%, (ii) 480V +10%, -20%	(i) 208V +15%, -20%; (ii) 400V +15%, -20% (iii) 440V +15%, -20%; (iv) 480V +10%, -20%			
Phases/Wires	3 phase 3 wires or 4 wires selectable for 208V and 400V model 3 phase 3 wires only for 440V and 480V model				
Nominal Frequency	50/60Hz ± 5% (Auto Sensing)				
Compensated Harmonic Orders	Global Mode: From 2nd to 51st order, including Even orders Selective Mode: Up to 30 orders simultaneously				
Power Factor Correction (Reactive Current)	Power factor correction is programmable from 0.6 lagging to 0.6 leading				
Load Balancing	Both phase to phase and phase to neutral				
Programmable Filtering Mode	<ol style="list-style-type: none"> 1. Harmonic compensation only 2. Power Factor (Reactive Current) compensation only 3. Harmonic compensation priority + Power Factor compensation 4. Power Factor compensation priority + Harmonic compensation 5. Harmonic compensation priority + Power Factor compensation + Load Balancing 				
CT Ratio	Programmable Primary Current: 100A~10000A Programmable Secondary Current: 1A/5A				
CT Location	CT at Source Side: Closed Loop Control CT at Load Side: Open Loop Control				
Response Time	Harmonic Compensation <1ms, Reactive Current Injection <20ms				
Inrush Current	Less than rated current				
Current Limitation	Yes, at full correcting				
Maximum Heat Losses	≤5% at full capacity				
Compensation Ratio	10:1 typical				
Power Electronics	3-Level IGBT Technology with DSP control				
Cooling	Forced air cooling with speed-controlled fans				
Display	7inch Colorful LCD Touch Screen				
Interface	USB, Ethernet (TCP/IP), RS-485 (Modbus RTU Protocol), EPO, 3x Output Dry Contact and 1x Input Dry Contact				
Type	Wall Mount				
Power Module Dimension (WxDxH, mm)	500 x 300 x 800mm (with HMI and built-in controller)	500 x 286 x 775mm (with HMI and built-in controller)			
Weight (kg)	47	51	58	59	60
Protection Index	IP31, other IP options available upon request				
Noise Level	< 65 dBA				
Environment	Indoor installation in clean environment up to 1000m altitude (higher altitudes with suitable derating)				
Operating Temperature	0°C to 40°C (up to 50°C with suitable derating)				
Safety Standard	EN50178				
EMC Compliance	EN 55011 Class A1, EN 61000-3, EN 61000-4, EN 61000-6				
Reference Design Standard	EN60146				
* the current rating may be derated automatically depending on load conditions for ambient temperature higher than 40 degree C.					

Supplied & Supported by:



HELIOS
POWER SOLUTIONS

ESP-W 1110/02