



# ***S/M - Platform installation guide***

AC / DC Rack Mount Power Systems

# 1. Introduction of RA-3048 DC power system

## 1-1 System overview

Switching Mode Rectifier (SMR) system provides uninterruptible and reliable DC power to wide variety of devices which require high quality DC source. With its high efficiency and compact size, RA-3048 rectifier module saves energy and space for system installers, which means more flexibility and less OPEX..

Multiple rectifiers can be configured by central control unit CE-R1 , which makes sure identical parameters setting and load sharing. Meanwhile, charging parameters monitoring and setting are completely considered in CE-R1, to make sure battery charging condition is optimized.

In our DC power system, protection mechanisms such as Input voltage protection and temperature protection are included. Hardware protection such as circuit breaker , SPD (Surge Protection Device- available with M system or above) and Low voltage Disconnect (LVDS) with battery can protect system further when necessary.

A complete DC power system is consisted of below elements in terms of function blocks:

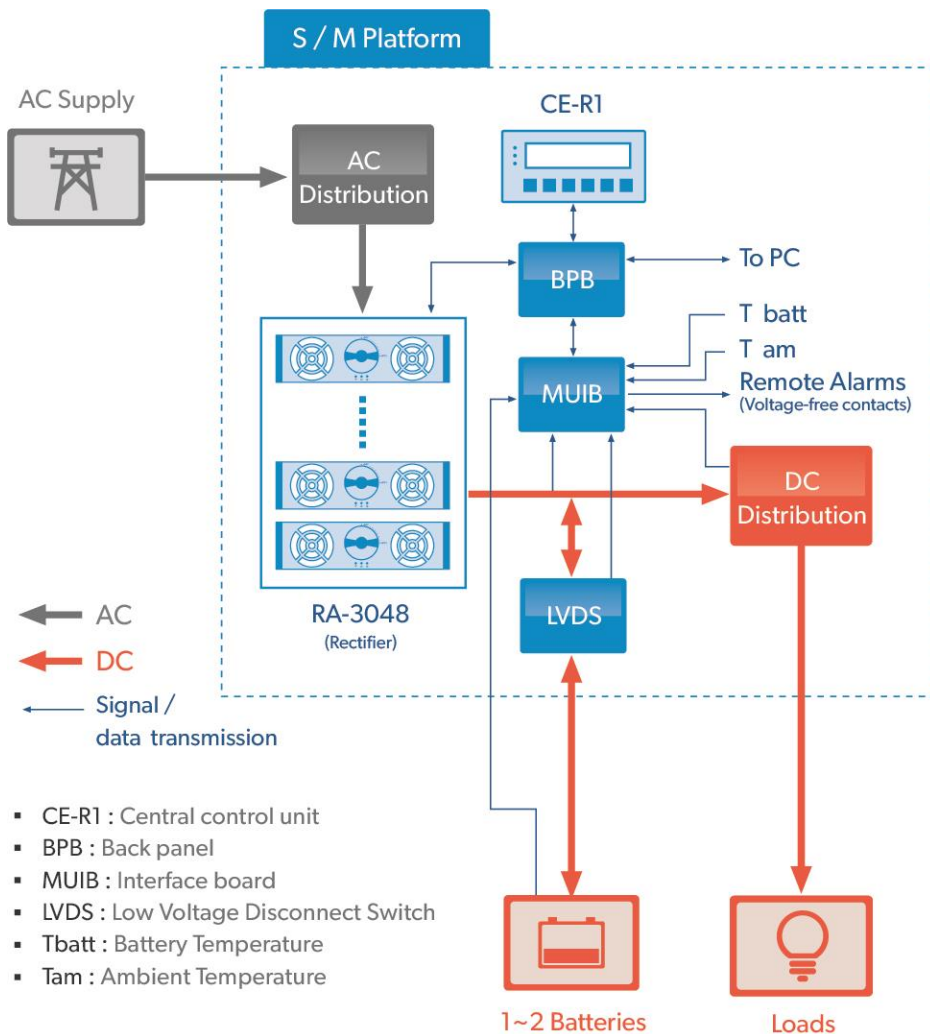

## 1-2 How S & M DC power system works

AC input distribution includes AC Switch (MNFB) and AC input terminals. All SMRs are in parallel and all DC outputs are connected to DC loads and batteries (Paralleled Battery modules) via DC distribution.

SMRs are charging Batteries when AC grid is present under the setting by CE-R1. When AC grid is not available, DC loads will be powered by batteries which avoids system down time. LVDS meanwhile can reduce the risk of battery deep discharge when AC grid is lost longer than expected. All system status and parameters can be monitored by CE-R1, and system alarm is triggered by dry contact relays on back panel.

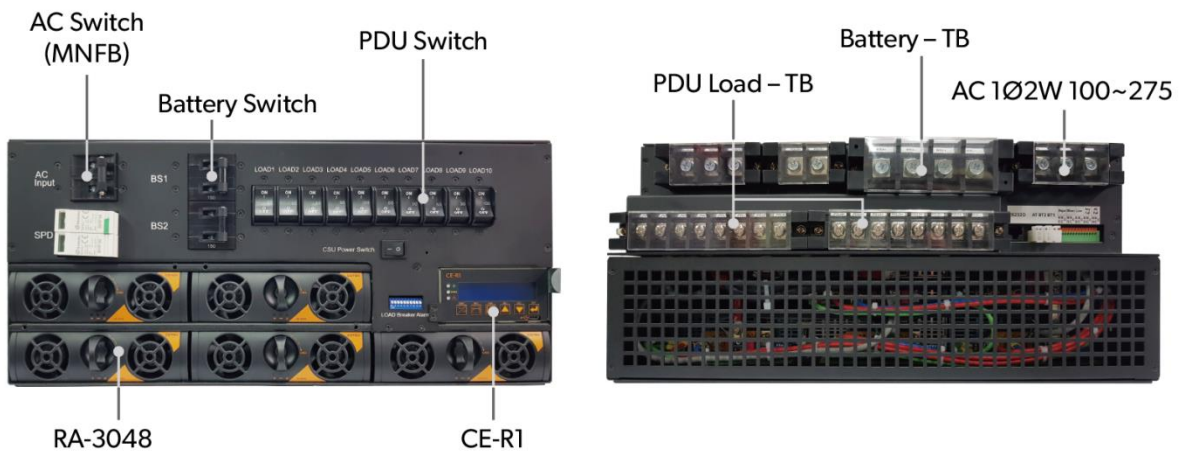

## 2. Pre-configured stock models



### S-Platform

19" 2RU Rack

### M-Platform

19" 4RU Rack

	S-Platform	M-Platform
<b>Part Number</b>	01-C101-0001	01-C101-0002
<b>Output Power (N+1)*</b>	6KW	12KW
<b>Maximum Output DC Current (N+1)</b>	125 A	250 A
<b>Total Height</b>	2U (3.5")	4U (7")
<b>Controller Slots</b>	1	1
<b>Rectifier Slots</b>	3	5
<b>Protected Load Outputs</b>	Up to 4	Up to 10
<b>Protected Battery Sets</b>	Up to 2	Up to 2
<b>Surge Protection Device</b>	No	Yes
<b>LVDS Switch</b>	Up to 1	Up to 2
<b>Additional Distribution Panel Option</b>	No	Yes
<b>Distribution Dimensions</b>	Height: 2U (3.5") Width: 19" (rack) Depth: 10.12"	Height: 4U (7") Width: 19" (rack) Depth: 10.12"
<b>DC terminal type</b>	1. TB Terminal 2. Euroblock terminal	

\* N+1 means a spare module is used for redundant supply, not regular output supply.

## 2-1. S / M Platform output power capability guide

Below table indicates the future expansion capability of the DC power system, M/S platform. If more output power is required, please contact our sales engineers they will assist your DC Power Requirements.

Below table does NOT consider N+1 situation and only shows full capacity output. However, a N+1 redundancy is always needed when any single SMR fails, in order to prevent system failure.



Platform	Present		Future		Maximum	
	No. SMR	W	No. SMR	W	No. SMR	W
<b>S-platform</b>	1	3000	2	6000	3	9000

	2	6000	1	3000		
	3	9000	0	0		
<b>M-platform</b>	1	3000	4	12000	5	15000
	2	6000	3	9000		
	3	9000	2	6000		
	4	12000	1	3000		
	5	15000	0	0		

### 3. Configuration List

Below indicates the devices configuration included in each pre-configured stock systems, which can be ordered on a regular basis.

		S-Platform	M-Platform
Photo	Component	Quantity	
	RA-3048 (Rectifiers)	3	5
	CE-R1 (Central control unit)	1	1
	AC Input Breaker	1	1
	Battery Breaker	2	2
	DC Load Breakers	4	10 (100A x 2, 50A x 6, 30A x 2)

	SPD	N/A	1
	Load Breaker Alarm DIP Switch	1	1

## 4. Operation Procedure

Please follow below steps for initial installation and operation.

### STEP 1:

Please check AC input no short condition before power ON , and check AC input whether 230VAC. If not, please check AC supply.



### STEP 2:

Please check if battery wiring is proper, Red line is positive connect to terminal block (P BAR), Blue line is negative, please check all connect point will be screw tight. If Yes, please turn ON the battery switch.



**STEP 3:**

Please check PDU LOAD wiring is proper, check all connect point will be screw tight. If Yes, turn ON the PDU switch. Complete Set up procedure.



**STEP 4:**

Please turn ON AC switch (MNFB).



After power ON 5 to 10 sec. Please check CE-R1 LED green light is ON. And no alarm message. Please check CE-R1 display condition: normal.

Please check all SMR LED green light is ON, and yellow light is NOT flashing.

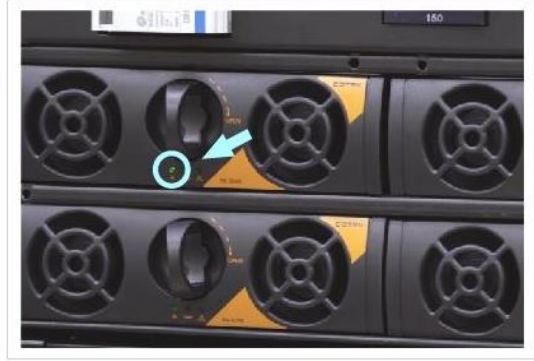



## 5. Introduction of RA-3048 / CE-R1

### 5-1. RA-3048 Rectifiers

- With 95% typical efficiency
- Input voltage range: 100 - 275 VAC
- 3000W DC output (constant power)
- 1U in height; 4.25" in width
- Hot-swap / hot-plug functionality
- Automatic active load sharing



RA-3048	
Input	
Voltage	Wide Input Range: 100-275 Vac, Max 3kW (100-184 Vac at de-rated output power)
Current (maximum)	16 ARMS
Frequency	45-66 Hz
Power Factor	>0.99 at 50-100% load
Input Protection	Fuse
Efficiency	> 95% (Load 40%~80%)
Surge Protection	IEEE C 62.41 / IEC 61000-4-5 / IEC 61000-4-4
Output	
Voltage	54 Vdc (adjustable range : 45-58 Vdc )
Static Regulation	±1.0% (10-100% load)
Current (maximum)	62.5 A (@ 48 Vdc)
Power (Max)	3000W @ 220Vac; 1000W @ 100Vac
Current sharing (10-100% load)	±5% of maximum current from 10 to 100% load sharing from CE-R1
Protection	Overvoltage-only faulty unit shunt down; Overcurrent-can sustain short circuit at output terminals indefinitely; Over-temperature - gradual reduction of current limit if heat-sink temperature exceeds pre-set limit
Dynamic Regulation	±5.0% for 10-90% or 90-10% load variation, output voltage regulation time < 2.5%. +/-1% within 2ms of step change.
Output Noise	< 10mVrms 10kHz - 100MHz; < 100mV peak to peak 0~30MHz bandwidth
Ripple	< 100 mV peak to peak, 30 MHz bandwidth
Other Specifications	

Surge Protection	IEC 61000-4-4 / IEC 61000-4-5 / IEEE C62.41
EMC	Emission : EN 61000-6-3; EN 61000-3-2; EN 61000-3-3. Immunity: EN61000-6-1; EN 61000-6-2
Inrush Current	<28.5 Arms peak at nominal mains voltage
Voltage Withstand Test	3.0 kVac - input and output (4.25 kVDC primary- secondary); 1.5kVac - input earth (2.12kVDC primary-ground)
Safety	UL 60950-1, UL62368-1 3rd , IEC62368-13rd , EN62368-1 3rd
Isolation	1.5 kVAC -input to earth, 500 VDC -output to earth
<b>Environmental</b>	
Acoustic noise,full load	< 55 dBA @ Tambient = 40°C
Operating temperature	Operating range -10°C ~ 70°C; derated power at 50°C ~ 70°C ; humidity 5-95% RH non-condensing
Storage temperature	-40 to +85°C ; humidity 0-99% RH non-condensing
Cooling	Fan (front to back airow, temperature and output current regulated speed)
<b>Mechanical</b>	
Dimension (W x H x D)mm	144 x 41 x 328 mm
Weight	2.1 kg (4.6 lbs)

\*For details, please refer to RA-3048 spec.

## 5-2. CE-R1 Central control unit

- Easy setting and intuitive warning message display
- Comprehensive rectifier system monitoring and setting in a single unit
- Advanced battery-monitoring and temperature compensation



	CE-R1
Input Voltage	18 – 70 VDC
Alarm Inputs	7
Output Relays	5
Computer Interface	RS232 or TCP/IP
Front Display	Graphic 144 x 32 dots
Temperature Sense Input	1 Ambient and 2 Battery temperature
Battery Current Monitor Input	2
Fuse Fail Monitor Input	1
LVDS Control	1
Dimensions (H x W x D)	45 mm (1.77") x 90 mm (3.54") x 280 mm (11.02")

\*For details, please refer to CE-R1 UM.

# 6. Instruction to replace RA-3048 and CE-R1

## 6-1. RA-3048

RA-3048 rectifier is design for hot pluggable while AC grid is present. Please see below steps for proper rectifier replacement:

### 6-1-1. Insert RA-3048 rectifier

**STEP 1:** Make sure the handle is at "OPEN" position, and pull it out from the shelf.



If you plug in RA-3048 into rack system when handle is at "LOCK" position, the handle might be damaged.

**STEP 2:** Insert the replacement rectifier module fully into the shelf until it fits the slot tightly. Wait for few seconds until the LED on replacement rectifier shows solid GREEN.



**STEP 3:** Turn the handle to “LOCK” position



**STEP 4:** CE-R1 will display “ communication fail” due to one module is inserted. Please enter the menu tree and change rectifier number to match latest rectifier quantity.



**CAUTION:** (1) The modules may be warm, but do not hand-carry them by their handles. Open the handles before inserting them into the power shelves (hot-pluggable). Please apply blind panels in unused module locations  
(2) No address setting is needed for each SMR. When plug the SMR into the power shelf, CE-R1 will assign corresponding address. However, correct SMR quantity needs to be input in CE-R1 after remove/add rectifiers in order for CE-R1 to calculate correct parameters.

## 6-2. CE-R1

**STEP 1:** Use the side handle to remove CE-R1 from the shelf. RA-3048 rectifier modules are operating normally even without CE-R1.



**STEP 2:** Insert the replacement control unit fully into the shelf until it fits the slot tightly. Wait for few seconds until the LED on replacement CE-R1 shows solid GREEN.

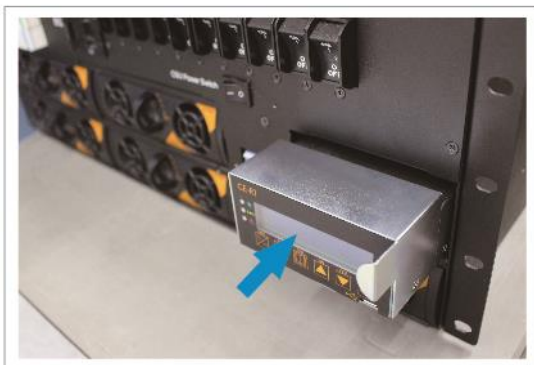

**STEP 3:** Please set desired parameters on replacement CE-R1 , or the settings will follow factory default value when inserting new control unit.