

800 Watts

HDS800 Series



- High Efficiency up to 92%
- 1U Profile, High Power Density
- Programmable Output Voltage (0-105%)
- Programmable Output Current (0-105%)
- Parallel Operation
- Fully Featured Signals & Controls
- 3 Year Warranty

Specification

Input

Input Voltage	• 90-264 VAC (127-370 VDC), see derating curve
Input Frequency	• 47-63 Hz
Input Current	• 9.3 A/3.7 A typical at 100/240 VAC
Inrush Current	• 30.0 A/60.0 A typical at 115/230 VAC
Power Factor	• 0.98/0.95, typical at 115/230 VAC full load
Earth Leakage Current	• <1.0 mA at 264 VAC/60 Hz
Input Protection	• T or F15 A/250 V internal fuse

Output

Output Voltage	• See model table
Output Trim	• $\pm 5.0\%$ by potentiometer
Output Voltage Program	• 0-105% of rated output
Output Current Program	• 0-105% of rated output
Initial Set Accuracy	• $\pm 1\%$
Minimum Load	• No minimum load required
Start Up Delay	• 800 ms maximum
Start Up Rise Time	• 100 ms maximum at full load
Hold Up Time	• 8 ms minimum
Line Regulation	• $\pm 1\%$
Load Regulation	• V1: $\pm 1\%$, standby output: $\pm 3\%$
Transient Response	• <1% for a 25% step load change
Ripple & Noise	• 150 mV pk-pk all voltages, see note 1
Overvoltage Protection	• Tracks output voltage. See application notes, Recycle AC to reset
Overtemperature Protection	• Primary and secondary heatsinks monitored. Output shuts down, auto recovers
Overload Protection	• >105% rated power, constant current
Short Circuit Protection	• Auto recovery
Temperature Coefficient	• $\pm 0.02\%/^{\circ}\text{C}$ (0-50 $^{\circ}\text{C}$)
Remote Sense	• Compensates for 0.5 V max voltage drop If remote sense is not required, local sense must be used
Enable	• Output must be enabled. See application notes, power supply is shipped with enable links fitted
Current Share	• 5 supplies can share within 5%
Standby Output	• 5 V at 0.5 A, present whenever AC is applied (9V at 0.3A, user selectable, by connecting 'VSET', Pin 8 of CN2 to 'GND')

General

Efficiency	• See model table
Isolation	• 3000 VAC Input to Output, 1500 VAC Input to Ground, 500 VAC Output to Ground
Switching Frequency	• PFC 65 kHz typical, PWM 40-200 kHz variable
Power Density	• 10.1 W/in ³
Signals & Controls	• Enable, Current Share, V Program, I Program, 5 V Standby, PWM switching
MTBF	• 90 kHrs to MIL-HDBK-217F at 25 $^{\circ}\text{C}$

Environmental

Operating Temperature	• -20 $^{\circ}\text{C}$ to 70 $^{\circ}\text{C}$, derate linearly from 100% load at 50 $^{\circ}\text{C}$ to 50% load at 70 $^{\circ}\text{C}$
Cooling	• Internal fan fitted. Speed increases with load and internal temperature
Operating Humidity	• 20-90% R.H. non-condensing
Storage Temperature	• -40 $^{\circ}\text{C}$ to +85 $^{\circ}\text{C}$
Storage Humidity	• 10-95% R.H.
Vibration	• 10-500 Hz, 2g 10 min/cycle, 60 min period for each axis. Compliant to IEC68-2-6, IEC 68-2-64

EMC & Safety

Emissions	• EN55032 class A conducted & radiated
Harmonic Currents	• EN61000-3-2 class A
Voltage Flicker	• EN61000-3-3
ESD Immunity	• EN61000-4-2, ± 4 kV contact, ± 8 kV air discharge, Perf Criteria A
Radiated Immunity	• EN61000-4-3, 3 V/m, Perf Criteria A
EFT/Burst	• EN61000-4-4, level 2, Perf Criteria A
Surge	• EN61000-4-5, installation class 3, Perf Criteria A
Conducted Immunity	• EN61000-4-6, 3 V, Perf Criteria A
Magnetic Field	• EN61000-4-8, 1 A/m, Perf Criteria A
Dips & Interruptions	• EN55024, >95% 10 ms, 30% 500 ms, >95% 5000 ms, Perf Criteria A, A, B
Safety Approvals	• UL62368-1, CSA C22.2 No 62368-1-14, EN 62368-1, IEC62368-1:2014, CE (Meets all applicable directives), UKCA (Meets all applicable legislation)

Output Power	Output Voltage V1	Output Current		Efficiency ⁽²⁾	Model Number
		Min	Max		
800 W	12.0 VDC	0.0 A	66.7 A	89%	HDS800PS12
800 W	15.0 VDC	0.0 A	53.4 A	90%	HDS800PS15
800 W	24.0 VDC	0.0 A	33.5 A	92%	HDS800PS24
800 W	30.0 VDC	0.0 A	26.7 A	92%	HDS800PS30
800 W	36.0 VDC	0.0 A	22.3 A	92%	HDS800PS36
800 W	48.0 VDC	0.0 A	16.7 A	92%	HDS800PS48
800 W	60.0 VDC	0.0 A	13.4 A	92%	HDS800PS60

Notes

- Ripple & noise is measured with 20 MHz bandwidth and using 12" twisted pair-wire terminated with 0.1 μF & 47 μF capacitors in parallel.
- Measured with 230 VAC input and full load.

Mechanical Details

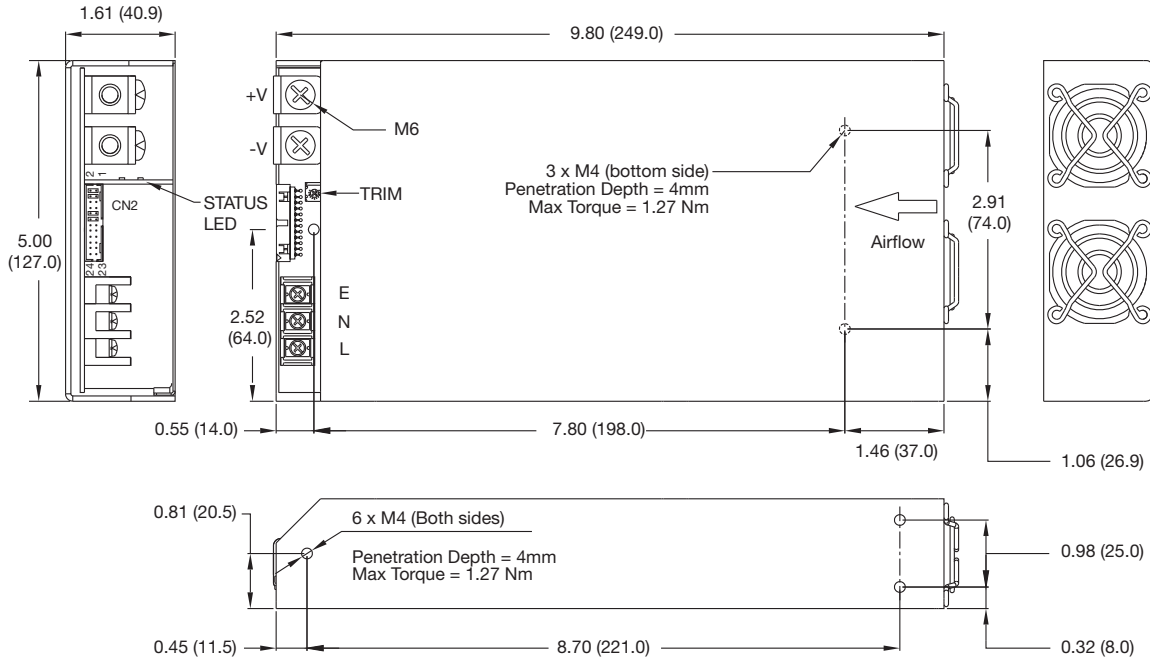

Mating connector CN2: Manufacturer :JST Housing:
PHDR-24VS
Contacts: SPHD-002T-P0.5
(28-24 AWG)

Notes

- All dimensions are in inches (mm).
 - Weight 3.85 lb (1.75 kg)
 - Maintain 2" (50mm) clear space at each end.
- *Only usable with driver board "KIT-RS232-X" or "KIT-RS485-1"

CN2 Control Pin Connections								
Pin	Function	Description	Pin	Function	Description	Pin	Function	Description
1	VS+	Remote sense (+)	9	EN-	Inhibit On/Off(-)	17	AUX	+5V/0.5 A or +9V/0.3 A Standby power
2	VO+	Positive Output Voltage	10	GND	Ground	18	GND	Ground
3	VS-	Remote Sense (-)	11	EN+	Inhibit On/Off (+)	19	SCL	I ² C Serial Clock
4	VO-	Negative Output Voltage	12	AUX	+5V/0.5 A or +9V/0.3 A Standby power	20	SDA	I ² C Serial Data
5	POK	Power OK	13	ACI	I Program	21	AUX	+5V/0.5 A or +9V/0.3 A power
6	GND	Ground	14	GND	Ground	22	GND	Ground
7	PAR	Parallel Operation Current Share	15	VCI	V Program	23	RX*	Receive
8	VSET	Aux Output Setting	16	GND	Ground	24	TX*	Transmit

Derating Curve

Thermal Derating Curve

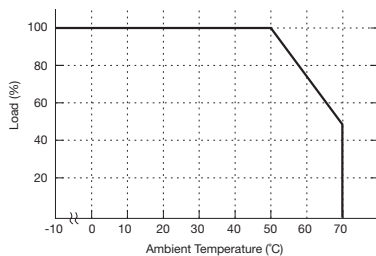

Input Derating Curve

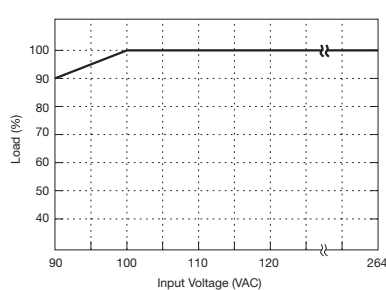

LED Status

LED Status	Output Status
Solid (Green)	DC Output OK
Solid (Orange)	DC Output OK in remote control mode
Slow Blink (Green)	Output Not Enabled
Fast Blink (Red)	Over Voltage
Solid (Red)	Over Loaded
Slow Blink (Red)	Over Temperature
Intermittent Blink (Red)	Fan Fail
Short & Long Blink (Red)	AUX Standby Failure

Output Voltage Programming

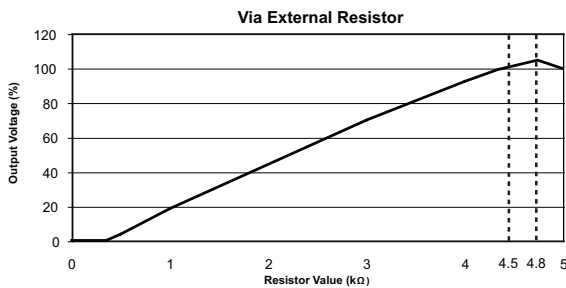
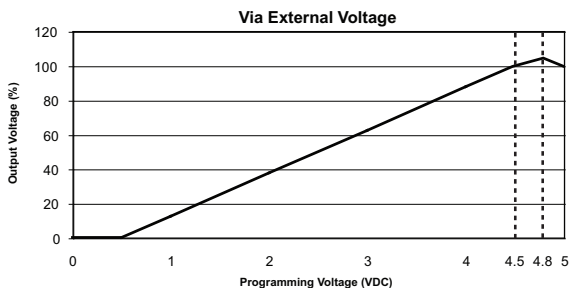

Output Current Program

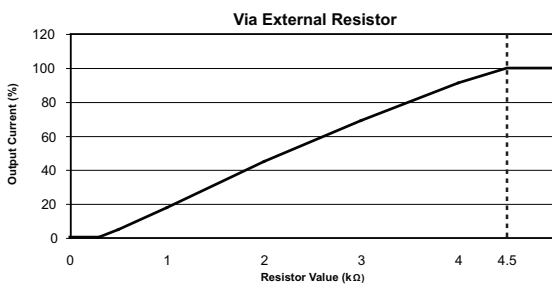
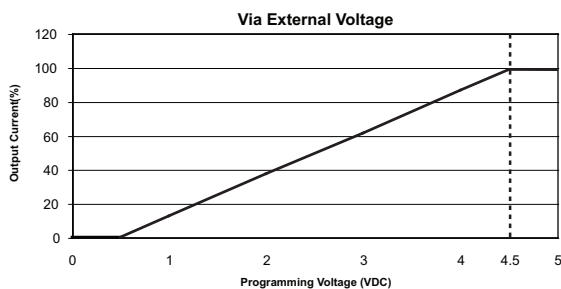

Remote Enable

*GND shown in the diagram (below) is referring to the GND of CN2, not the Grounding from output power (V-)

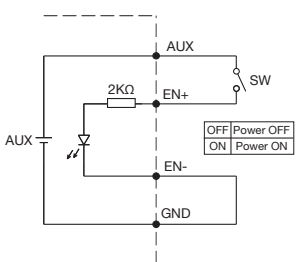

(A) Using internal auxilliary standby

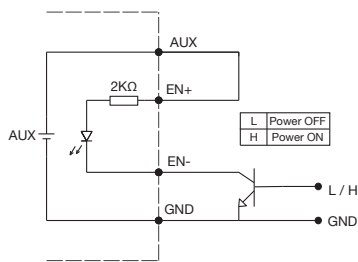

(B) Using external transistor

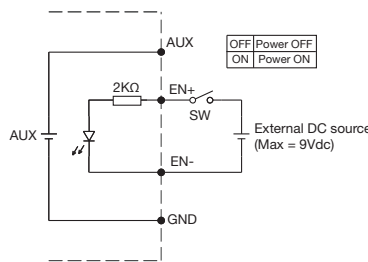

(C) Using external voltage source

External Programming Voltage Connection

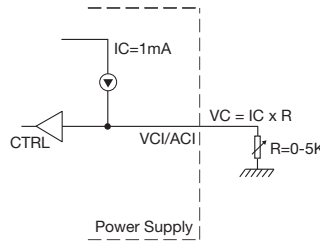
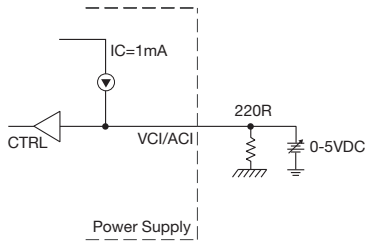
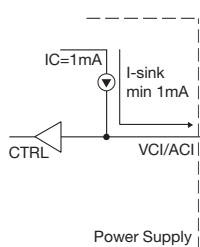

POK Signal

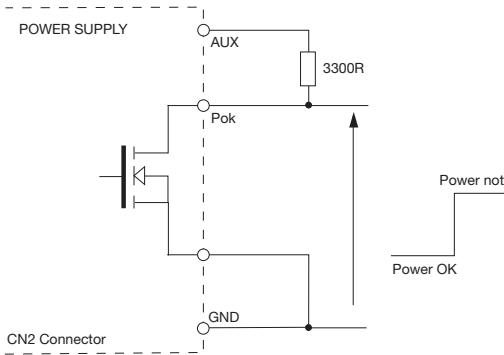

Open drain signal, low when PSU turns on
 Maximum sink current: 20 mA
 Maximum drain voltage: 40 V

OVP Setting

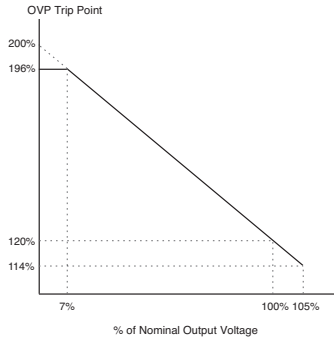

Current Share

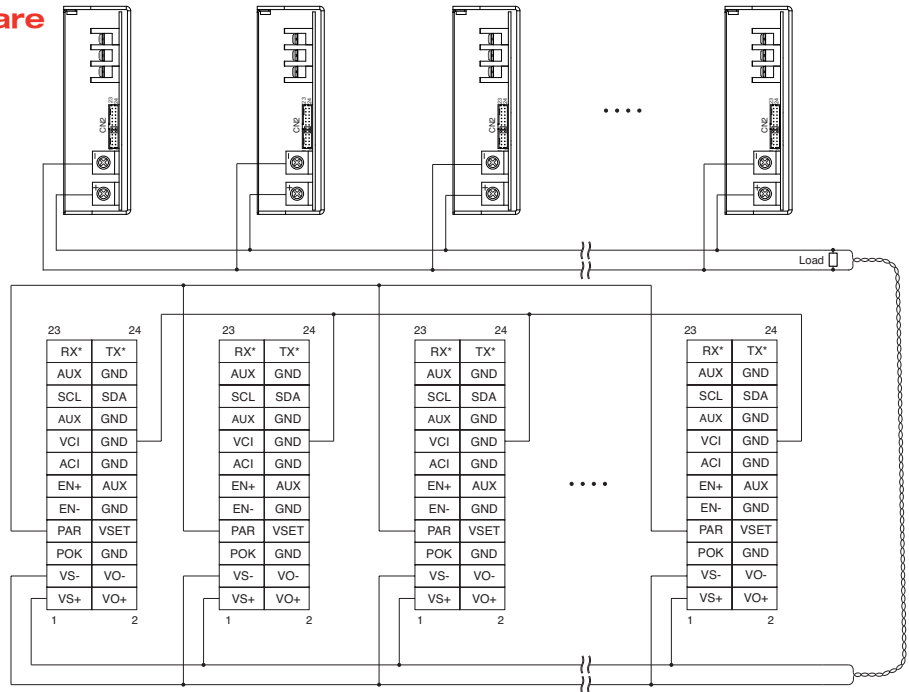

Remote Sense

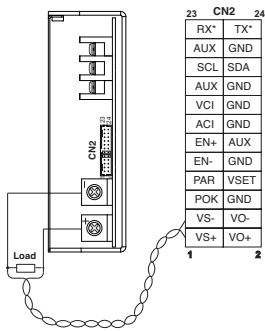

Local Sense

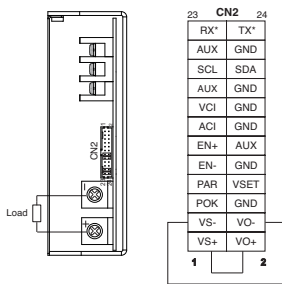

Must be used if remote sense is not required.

Current Sharing with Remote Sensing

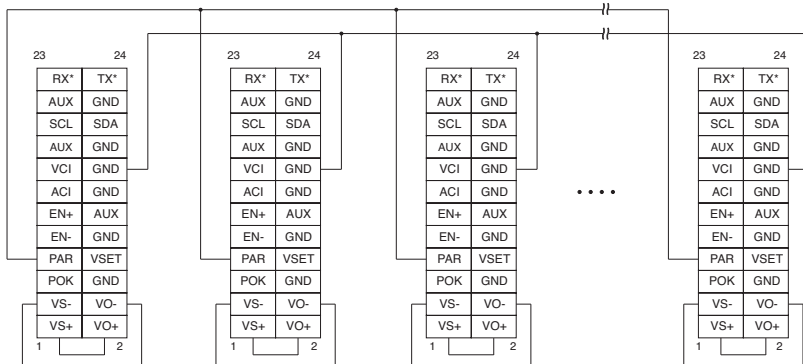

Current Sharing with Local Sensing

Notes

In parallel operation, it is possible that only one unit will operate if the load is less than 5% of the combined rated output load. It is possible to have more than five units in parallel, contact sales for details.
 *Pin 23 and 24, Only usable with driver board "KIT-RS232-X" or "KIT-RS485-1"