

Leading Conversion Technology for Power Resilience

# SIERRA 10 - 48/230

## User Manual V1.3

### THE NEW GENERATION OF POWER CONVERTERS

- **DUAL AC AND DC OUTPUT CONVERTER**  
Commercial Power as default source
- **AC AND DC BACKUP IN A DC ENVIRONMENT**  
Leverage your existing DC infrastructure
- **ONE STOP SHOP**  
Wide output power range
- **HARSHEST AC INPUT CONDITIONS**  
Without compromising the quality of the AC output

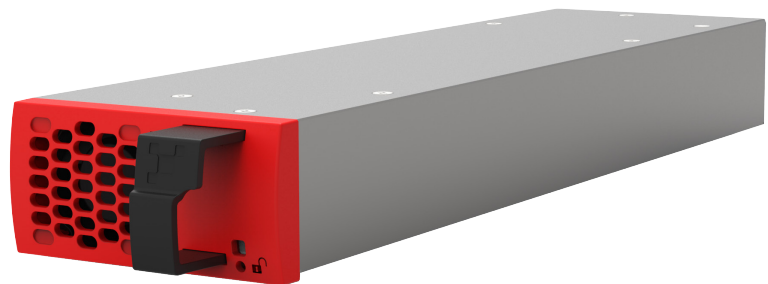

## Table of Contents

1. Introduction to CE+T .....	6
2. Abbreviations .....	7
3. Warranty and Safety Conditions .....	8
3.1 Disclaimer .....	8
3.2 Technical care .....	8
3.3 Installation .....	9
3.3.1 Handling.....	9
3.3.2 Surge and transients .....	9
3.3.3 Other.....	9
3.4 Maintenance .....	10
3.5 Replacement and Dismantling.....	10
4. ECI TECHNOLOGY.....	11
4.1 EPC mode .....	12
4.2 Back up mode .....	12
5. Building Blocks .....	13
5.1 Sierra 10 - 48/230 .....	13
5.1.1 Specifications.....	13
5.2 Sub-rack.....	15
5.3 Controller - Inview Slot.....	15
5.3.1 Inview Slot - Connections .....	15
5.4 Controller - Inview S.....	16
5.4.1 Inview S - Connections.....	17
5.5 Measure Box Battery (MBB).....	17
5.6 Manual By-Pass .....	18
6. A la Carte.....	19
7. Installation of Sierra 10 - Shelf.....	20
7.1 Mounting kit for Sierra 10 - shelf.....	20
7.2 Electrical installation for Sierra 10 - shelf .....	21
7.2.1 Pre requisites .....	21
7.2.2 Terminations .....	21
7.2.3 Cable Routing and Fixation .....	22
7.2.4 Grounding .....	22
7.2.5 DC.....	22
7.2.6 AC Input .....	23
7.2.7 AC Output.....	23
7.2.8 Inview S with Sierra 10 System - Connections.....	24
7.2.9 Signalling .....	24
8. Interface .....	26
8.1 Converter module.....	26

8.2	Inview S - LCD Display .....	27
8.2.1	LED indications .....	27
8.2.2	Menu structure.....	28
8.3	Inview Slot - LCD Display .....	28
8.3.1	LED indications .....	29
8.3.2	Menu structure.....	29
8.4	Inview S and Inview Slot - Web Interface .....	29
8.4.1	Login.....	30
8.4.2	Interface Areas .....	30
<b>9.</b>	<b>Replacement procedures .....</b>	<b>32</b>
9.1	Module - Sierra 10 .....	32
9.1.1	Removal.....	32
9.1.2	Inserting.....	32
9.2	Controller - Inview Slot.....	33
9.2.1	Removal.....	33
9.2.2	Inserting.....	33
9.3	Controller - Inview S.....	34
9.3.1	Panel Mounting .....	34
9.4	Module Fan .....	35
9.4.1	Fan Removal .....	35
9.4.2	Fan Installation.....	36
<b>10.</b>	<b>Manual By-Pass (Optional) .....</b>	<b>37</b>
10.1	Pre-requisites.....	37
10.2	Manual By-Pass Operation .....	37
10.2.1	Normal to By-pass (Engage MBP).....	37
10.2.2	By-pass to Normal (Disengage MBP) .....	38
10.3	MBP Auxiliary connection .....	38
<b>11.</b>	<b>Finishing .....</b>	<b>39</b>
<b>12.</b>	<b>Commissioning .....</b>	<b>40</b>
12.1	Check list.....	41
<b>13.</b>	<b>Trouble Shooting and Defective Situations Fixing.....</b>	<b>42</b>
13.1	Trouble Shooting .....	42
13.2	Defective modules.....	43
<b>14.</b>	<b>Maintenance .....</b>	<b>44</b>
14.1	Access Inview with Laptop .....	44
14.2	Manual check.....	44
14.3	Optional .....	44
14.4	Manual By-Pass .....	44
<b>15.</b>	<b>Service .....</b>	<b>45</b>
<b>16.</b>	<b>Appendix.....</b>	<b>46</b>
16.1	Mains connection - Single phase.....	46
16.2	Mains connection - Three phases .....	47

---

16.3	Sierra 10 - 48/230 - Dimensions .....	48
16.3.1	Module .....	48
16.3.2	Shelf .....	48
16.4	Sierra-10-Parallel Kit 2/3 shelves (P602006010) .....	49
16.4.1	Bus Cable Installation: .....	49
16.4.2	DC Copper Bar Positioning: .....	50
16.4.3	Copper bar placement, cables connection and screws adaptation:.....	50
16.5	Inview S with MBB - Wiring diagram.....	53
16.6	Inview Slot with MBB - Wiring diagram.....	54
16.7	Modules - Parameter List .....	55

Release Note:

Version	Release date (DD/MM/YYYY)	Modified page number	Modifications
1.0	14/02/2020	-	First release of the Manual.
1.1	29/05/2020	47	Added module and shelf dimension images
1.2	15/06/2021	18 and 35 - 36	Updated mounting kit and fan replacement procedure
1.3	21/04/2022	49 - 52	Added Parallelization kit information.

# 1. Introduction to CE+T

---

CE+T Power designs, manufactures and markets a range of products for industrial operators with mission critical applications, who are not satisfied with existing AC backup systems performance and related maintenance costs.

Our product is an innovative AC backup solution that unlike most used UPS's

- Maximizes the operator's applications uptime;
- Operates with lowest OPEX;
- Provides best protection to power disturbances;
- Optimizes footprint.

Our systems are:

- Modular
- Truly redundant
- Highly efficient
- Maintenance free
- Battery friendly

CE+T puts 60+ years expertise in power conversion together with worldwide presence to provide customized solutions and extended services 24/7 – 365 days a year.

## 2. Abbreviations

---

AC	Alternating current
DC	Direct current
DHCP	Dynamic Host Configuration Protocol
DSP	Digital Signal Processor
ECI	Enhanced Conversion Innovation
EPC	Enhanced Power Conversion
ESD	Electro Static Discharge
ETH	Ethernet
HTTP	HyperText Transfer Protocol
HTTPS	Secure HyperText Transfer Protocol
LAN	Local Access Network
MBB	Measure Box Battery
MBP	Manual By-pass
MET	Main Earth Terminal
MIB	Management Information Base
N	Neutral
NTP	Network Time Protocol
NUA	Non-Urgent Alarm
PCB	Printed Circuit Board
PE	Protective Earth (also called Main Protective Conductor)
PWR	Power
REG	Regular
SNMP	Simple Network Management Protocol
TCP/IP	Transmission Control Protocol/Internet Protocol
TRS	True Redundant Structure
UA	Urgent Alarm
USB	Universal Serial Bus

## 3. Warranty and Safety Conditions\*

### WARNING:

The electronics in the power supply system are designed for an indoor, clean environment.

When installed in a dusty and/or corrosive environment, indoor, it is important to:

- Install an appropriate filter on the enclosure door, or on the room's air conditioning system.
- Keep the enclosure door closed during operation.
- Replace the filters on a regular basis.

**Important Safety Instructions, Save These Instructions.**

### 3.1 Disclaimer

- The manufacturer declines all responsibilities if equipment is not installed, used or operated according to the instructions herein by skilled technicians according to local regulations.
- Warranty does not apply if the product is not installed, used or handled according to the instructions in the manual.
- This equipment is shipped with a SHOCKWATCH monitor. If the SHOCKWATCH shows that the equipment was exposed to excessive force the warranty will be void.

### 3.2 Technical care

- This electric equipment can only be repaired or maintained by a "qualified employee" with adequate training. Even personnel who are in charge of simple repairs or maintenance are required to have knowledge or experience related to electrical maintenance.
- Please follow the procedures contained in this Manual, and note all the "DANGER", "WARNING" AND "NOTICE" marks contained in this Manual. Warning labels must not be removed.
- Qualified employees are trained to recognize and avoid any dangers that might be present when working on or near exposed electrical parts.
- Qualified employees know how to lock out and tag out machines so the machines will not accidentally be turned on and injure employees working on them.
- Qualified employees also know safety related work practices, including those by OSHA and NFPA, as well as knowing what personal protective equipment should be worn.
- All operators are to be trained to perform the emergency shut-down procedure.
- Never wear metallic objects such as rings, watches, or bracelets during installation, service and maintenance of the product.
- Maximum operating ambient temperature is 40°C (104°F).
- Insulated tools must be used at all times when working with live systems.
- When handling the system/units pay attention to sharp edges.
- This product is suitable for use in a computer room.

\* These instructions are valid for most CE+T Products/Systems. Some points might however not be valid for the product described in this manual.



### 3.3 Installation

- This product is intended to be installed only in restricted access areas as defined by local regulations and in accordance with the National Electric Code, ANSI/NFPA 70, or equivalent agencies.
- The Converter System may contain output over current protection in the form of circuit breakers. In addition to these circuit breakers, the user must observe the recommended upstream and downstream circuit breaker requirements as defined in this manual.
- Please use extreme caution when accessing circuits that may be at hazardous voltages or energy levels.
- The modular converter rack is a dual input power supply. The complete system shall be wired in a way that both input and output leads can be de-energized when necessary.
- REG systems and EPC systems that have no AC input wired and connected can be seen as independent power sources. To comply with local and international safety standards N (input) and PE shall be bonded. The bonded connection between N (input) and PE must be removed once the AC input is connected.
- AC and DC circuits shall be terminated with no voltage / power applied (de-energized).
- The safety standard IEC/EN62040-1-1 requires that, in the event of an output short circuit, the converter must disconnect in 5 seconds maximum. The parameter can be adjusted on Inview; however, if the parameter is set at a value > 5 seconds, an external protection must be provided so that the short circuit protection operates within 5 seconds. Default setting is 60 seconds.
- The system is designed for installation within an IP20 environment. When installed in a dusty or humid environment, appropriate measures (air filtering) must be taken.
- All illustrations in the manual are for general reference, refer to the technical drawing which is received along with the system for exact information.

#### 3.3.1 Handling

- The cabinet shall not be lifted using lifting eyes.
- Remove weight from the cabinet by unplugging the converters. Mark converters clearly with shelf and position for correct rebuild. This is especially important in dual or three phase configurations.
- Empty converter positions must not be left open. Replace with module or dummy cover.

#### 3.3.2 Surge and transients

The mains (AC) supply of the modular converter system shall be fitted with Lightning surge suppression and Transient voltage surge suppression suitable for the application at hand. Manufacturer's recommendations of installation shall be adhered to. Selecting a device with an alarm relay for function failure is advised.

Indoor sites are considered to have a working lightning surge suppression device in service.

- Indoor sites Min Class II.
- Outdoor sites Min Class I + Class II or combined Class I+II. The modular converter system/rack can reach hazardous leakage currents. Grounding must be carried out prior to energizing the system. Grounding shall be made according to local regulations.

#### 3.3.3 Other

- Insulation test (Hi-Pot) must not be performed without instructions from the manufacturer.

### 3.4 Maintenance

- The converter system/rack can reach hazardous leakage currents. Earthing must be carried out prior to energizing the system. Earthing shall be made according to local regulations.
- Prior to any work conducted to a system/unit, make sure that AC input voltage and DC input voltage are disconnected.
- Prior to accessing the system or modules, make sure all source of supply is disconnected.  
**CAUTION** – Risk of electric shock. Capacitors store hazardous energy. Do not remove cover until 5 minutes after disconnecting all sources of supply.
- Some components and terminals carry high voltage during operation. Contact may result in fatal injury.

### 3.5 Replacement and Dismantling

- ESD Strap must be worn when handling PCB's and open units.
- The converter system/rack is not supplied with internal disconnect devices on input nor output.
- CE+T cannot be held responsible for disposal of the converter system and therefore the customer must segregate and dispose of the materials which are potentially harmful to the environment, in accordance with the local regulations in force in the country of installation.
- If the equipment is dismantled, to dispose of its component products, you must comply with the local regulations in force in the country of destination and in any case avoid causing any kind of pollution.

To download the latest documentation and software, please visit our website at [www.cet-power.com](http://www.cet-power.com)

# 4. ECI TECHNOLOGY<sup>1</sup>

Sierra module built with ECI technology and it is a triple port converter. This module deliver pure sinusoidal output and ripple free DC output from AC mains or battery.

The below block diagram gives an explicit description of the topology and its operation.

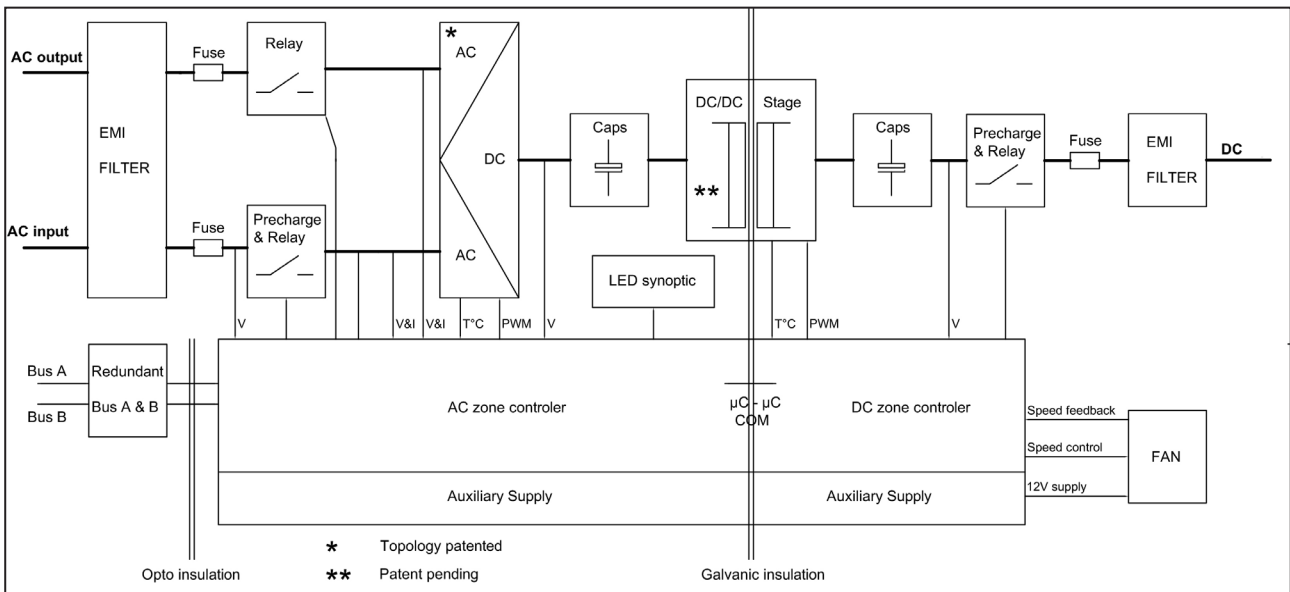

ECI technology has AC to DC, DC to AC, and DC to DC converters to provide constant and disturbance-free output power regardless of the input source.

The power flows either from AC or DC source under the control of the DSP controller. Thanks to internal energy buffering for transferring the load between two input sources by 0 ms.

In the case of a short circuit at the AC output, the converter will provide 4 x I<sub>n</sub> during 20 ms to force output MCB to trip. Breaker selectivity shall be adapted according to the power available.

Sierra module works on True Redundant Structure (TRS) that features decentralized, independent logic, and redundant communication bus.

Each Sierra module has three levels of protection, and it will help to isolate from other modules in case of any fault in the corresponding module. Due to this functionality in each module, it provides no single point of failure in modular systems.

The Sierra modular systems provide quality output power with higher efficiency.

<sup>1</sup> Information and data given in this chapter is intended to serve as an overview of the ECI Technology. Detailed features and parameters for each individual module type in the range may differ and should be referred to in the dedicated data sheet.

## 4.1 EPC mode

In EPC mode, the AC Mains is the primary source and DC source works as a backup. When AC mains is present, the sierra module takes energy from the AC source and feed to:

- AC Load via a double conversion to provide a pure sine wave.
- DC load and also charges the battery with a regulated DC.

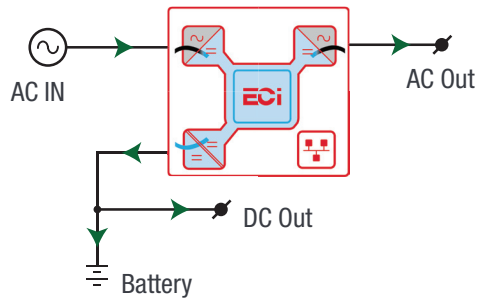

The total output power of a module can be shared between the AC load, DC load and charging power based upon the requirement.

If the AC source is not present, the module seamlessly switches to DC source without impacting the critical loads and resumes to EPC mode once AC source returns. The transfer time between AC to DC and DC to AC is 0 ms.

The EPC mode provides a higher efficiency of 96% without compromising the purity of the output sine wave.

## 4.2 Back up mode

In back up mode, module operates in DC source and feed to:

- AC Load via a double conversion to provide a pure sine wave.
- DC load directly.

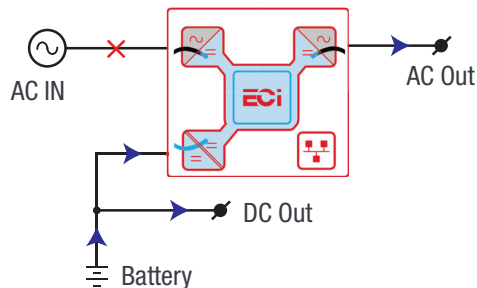

## 5. Building Blocks

### 5.1 Sierra 10 - 48/230

Telecom / Datacom:	Input	48 Vdc 230 Vac, 50/60 Hz
	Output	230 Vac and 48 Vdc
	Power	1250 VA / 1000 W



- The Sierra converter is a triple port converter.
- Each converter can supply 1000 W on any DC, AC or combination of both AC and DC output ports. AC output load is the highest priority. Even if AC / DC output is fully loaded (1000 W), still 200 W is available for AC / DC output.
- Hot swappable and hot pluggable.
- The front LED's indicate the converter status and output power.
- Module is equipped with soft start.
- Fan is equipped with alarm and run time meter. The fan is field replaceable.
- 346 mm (D) x 87 mm (W) x 1U (H).
- 1.2 Kg.

#### 5.1.1 Specifications

Model	Sierra 10 - 48/230
Part Number	T711730201
Cooling / Audible noise	Fan forced cooling / <65db @1meter
MTBF	200 000 hrs (MIL-217IF)
Dielectric strength DC/AC	4300 Vdc
RoHS	Compliant
Operating T° / Relative Humidity (RH) non-condensing	Tested according ETS300-019-2-3 Class 3.1 -20°C to 65°C, power de-rating from 40°C to 65°C / Max RH 95% for 96 hours per year
Storage T° / Relative Humidity (RH) non-condensing	Tested according ETS300-019-2-1 Class 1.2 -40°C to 70°C / Max RH 95% for 96 hours per year
Public transport T°/Relative Humidity (RH) non-condensing	Tested according ETS300-019-2-2 Class 3.1 -40°C to 70°C / Max RH 95% for 96 hours per year
Material (casing)	Zinc coated steel
AC Input Data	
Nominal voltage (AC) / Current	230 Vac / 4.6 A
Voltage range (AC)	150 - 265 Vac
Brownout	800 W @ 150 Vac / 1200 W @ 190 Vac linear decreasing
Power factor / THD	> 99% / < 3%
Frequency range (selectable) / synchronization range	50 Hz (range 47 – 53 Hz) / 60 Hz (range 57 – 63 Hz)

<b>DC Input Data</b>	
DC voltage: Nominal / range	48 Vdc / (40-60V)
Nominal current (at 48 Vdc and 1000 W output)	22.4 A
Maximum input current (for 15 second) / voltage ripple	34 A / < 10 mV RMS
<b>AC Output Data</b>	
Efficiency AC to AC (EPC) / DC to AC / AC to DC	96% / >93% / >93%
Nominal voltage AC (Adjustable)	230 V (200 - 240 Vac)
Frequency / frequency accuracy	50 or 60 Hz / 0.03%
Nominal Output power (VA) / (W)	1.25 kVA / 1 kW (at 1000 W AC load, still 200 W are available for 48V DC output)
Short time overload capacity	150% (15 seconds)
Admissible load power factor	Full power rating from 0 inductive to 0 capacitive
Total harmonic distortion (resistive load)	< 3%
Load impact recovery time (10% - 90%)	≤ 0.4 ms
Nominal current	5.4 A @ 230 Vac
Crest factor at nominal power	3 : 1 for load P.F. ≤ 0.7
Short circuit clear up capacity 0-20 ms	21.7 A for 20 ms
Short circuit current after 20 ms	9.9 A (20 ms to 15 s) , 7.4 A (15 s to 60 s) , > 60 s - manual reset is required
AC output voltage stability	±1% from 10% to 100% load
<b>DC Output Data</b>	
Nominal voltage (range)	53.5 Vdc (44 - 60 Vdc)
Maximum power	1.2 kW
Maximum current at 48 Vdc	20.8 A
Reverse polarity protection	YES
Efficiency AC to DC	> 93%
Max. Voltage interruption / total transient voltage duration (max)	0 sec / 0 sec
<b>Signaling &amp; Supervision</b>	
Display	Synoptic LED
Supervision / Part number	Inview ranges: Inview S - T302004100, Inview Slot - T602004110, Inview GW - T602004000
Remote on / off	On rear terminal of the shelf through Inview
Battery Monitoring / Part number	MBB (Measure Box Battery) - 6 dry contacts and 8 digital Inputs / T302006000
<b>Safety &amp; EMC</b>	
Safety	EN62040-1
EMC	EN 61000-4-2 / EN 61000-4-3 / EN 61000-4-4 / EN 61000-4-5 / EN 61000-4-6 / EN 61000-4-8 ETSI EN 300386 v1.9.1

## 5.2 Sub-rack

- The Sierra shelf shall be integrated in min 600 mm deep cabinets, 1inch/ETSI mounting.
- The shelf house max four modules and one Inview Slot.
- The extension shelf house max five modules.
- The Sierra shelf is designed with common DC input / output, common AC input and common AC output.
- Equipped with IP 20 rear cover.
- Max 6.25 kVA per shelf.
- 416 mm (D) x 19” (W) x 1U (H).
- 3.6 Kg (without modules).
- Subrack is also available with **AC distribution** (1 Inview Slot + 3 modules + AC distribution)

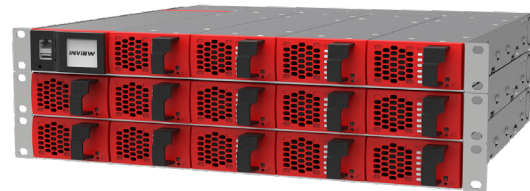

Sierra 10 - Subrack system



Sierra 10 - Subrack system with AC distribution

## 5.3 Controller - Inview Slot

**Inview Slot** is an advanced monitoring and controller unit for Bravo 10 and Sierra 10 power systems. The product is specially designed in 1U height to accommodate in the module shelf and reduces the additional space in the cabinet.

It allows the user to easily access the system information through inbuilt powerful LCD touch screen graphic display. In addition to the touch screen display, the user can also access the system information through the web interface.

The Inview Slot interface provides the user to access the configuration and setup files of the modules in the system.

Inview Slot can monitor up to 32 inverters/converters and featured with:

- LCD touch screen display
- 2 Digital Inputs
- 2 Output Relay contacts
- Records 5000 events as FIFO



*Note: In the Sierra shelf, signalling connections are present at left first slot. So the Inview Slot controller should be placed only at the left side of the first slot in the shelf, while you are looking from the front.*

### 5.3.1 Inview Slot - Connections

Inview Slot has an ETH port and USB at the front. Output relays, free potential contacts, Modbus and power connections are present at the rear side of the Inview Slot connected shelf.

#### Inview Slot - Front connections

- **LAN** port is used for network connectivity and user can access the system information in the Web Interface.
- **USB** port is used to access the Inview S configuration and setup files.

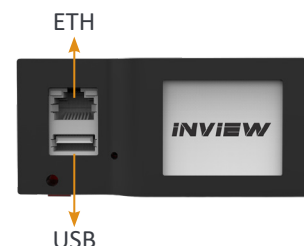

**Inview Slot - Shelf rear connections**

- **Digital Inputs (D1 and D2):** Two potential free Digital Inputs are available for customer connections.
  - Digital Input 1 is assigned for MBP operation if used.
  - Digital Input 2 is assigned for Surge Arrester if used.
- **Output Relays (K1 and K2):** Two output relays are available and can be used for Major and Minor Alarms.
- **CAN Modbus (RS485) port** is used to establish communication between Inview Slot and MBB. It also provide the +12 Vdc power to one connected MBB.
- **Power:** The additional +12 V for Inview Slot and it is from external Auxiliary power supply converter. This power should not be shared with other devices.

Note: By default, Inview Slot works on system DC. If DC is not present, it takes +12 V from external Auxiliary power supply converter (AC to DC).

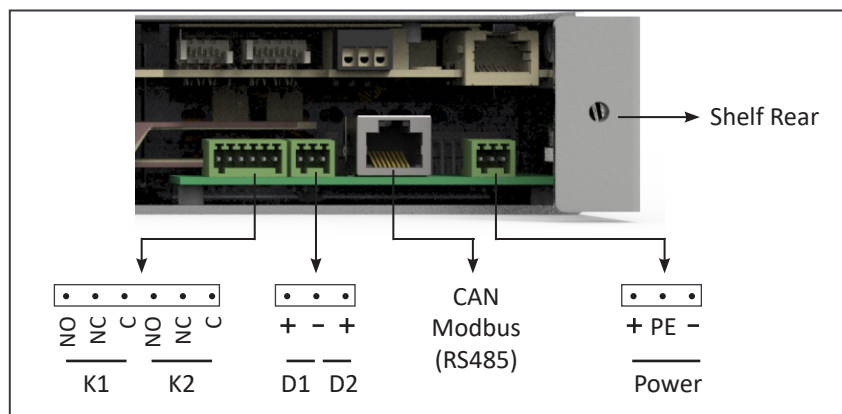

**5.4 Controller - Inview S**

**Inview S** is an advanced monitoring and controller unit for **Bravo 10**, **Sierra 25**, and **Sierra 10** power systems. It allows the user to easily access the system information through inbuilt powerful touch screen graphic display. In addition to the touch screen display, the user can also access the system information through the web interface and SNMP protocol.

The Inview S interface provides the user to access the configuration and setup files of the modules in the system. Also, it is a controller for DC regulation.

Inview S can monitor up to 32 inverters/converters and featured with:

- LCD touch screen display
- 2 Digital Inputs
- 2 Output Relay contacts
- Records 5000 events as FIFO





### 5.4.1 Inview S - Connections

Inview S is composed of multiple network ports and inbuilt free potential contacts.

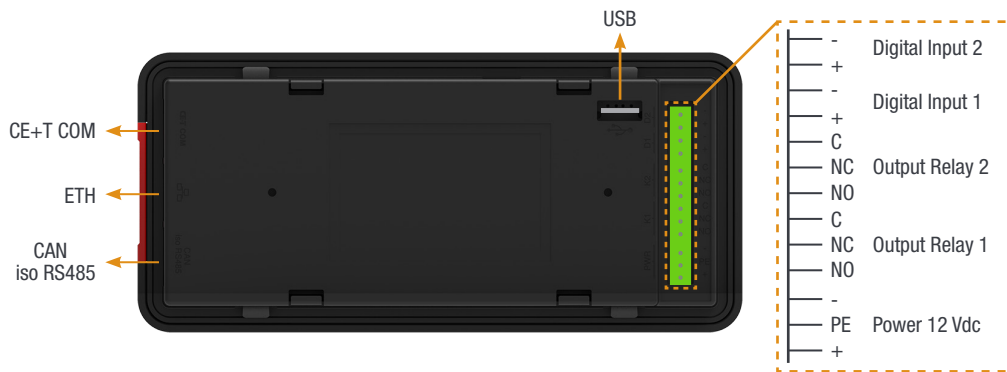

- CE+T COM port is dedicated to establish connection between Inview S and Sierra 10 - shelf.
- ETH port is used for network connectivity and user can access the system information in the Web Interface.
- CAN / iso RS485 is used share the system (DC) information to MBB (Measure Box Battery).  
(Note: In future version, user can use this port for RS485-Modbus communication)
- USB port is used to access the Inview S configuration and setup files.
- Digital Inputs (D1 and D2): Two potential free Digital Inputs are available for customer connections.
  - Digital Input 1 is assigned for MBP operation if used.
  - Digital Input 2 is assigned for Surge Arrester if used.
- Output Relays (K1 and K2): Two output relays are available and can be used for Major and Minor Alarms.
- Power: The unregulated separate +12 V power supply is required for powering Inview S and this power should not be shared with other devices. (CET can provide Auxiliary Power Supply converter and the part number is T602004120).

### 5.5 Measure Box Battery (MBB)

Measure Box Battery is a unit which monitors the Battery. It is composed of multiple digital inputs and analog outputs. They are used for:

- Battery management
  - Voltage (V1 to V3)
  - Current (I1 to I3)
  - Temperature (T1 and T2)
  - Driving the Low Voltage Disconnection
- 8 Digital Input (D1 to D8)
- 6 Output Relay (k1 to K6)



## 5.6 Manual By-Pass

The manual by pass operates via manually operated switches to create a short circuit from the AC main input directly to the output AC distribution. Standard manual by-pass is “Make before Break”. When engaged or disengaged, no disturbance is transmitted to the load.

When MBP is engaged, converter modules are switched off and can be removed without impacting the load. The battery supply is not physically disconnected. After disconnecting the battery supply (by opening the battery breakers), the shelf section is safe for maintenance.

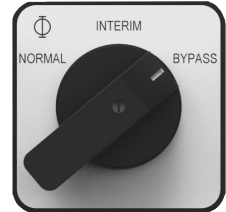

**Warning:** When the system is in by-pass, the load is subjected to AC main disturbances. Before engaging manual bypass, make sure the voltage difference between AC IN and AC OUT should be less than 5 Vac to limit the inrush current.

## 6. A la Carte

The A la Carte is pre-assembled and configured as a single phase or three phase system. The system comprises cabinet, converter sub rack, Sierra 10 modules and controller.



*Sierra 10 System with Inview S*



*Sierra 10 System with Inview Slot*

Sierra system featured with:

- Dual input (AC & DC).
- Dual output for AC and DC loads.
- 96% efficiency during normal operation (EPC).
- Pure sinusoidal AC output and ripple free DC output.
- Seamless transfer (0 ms) between primary and secondary source of supply.
- No single point of failure.
- Flexible output distribution.
- True modularity, redundancy and hot-swappable.

### Optional

- Manual by-pass
- AC output distribution
- DC distribution
- Battery fuses
- Battery LVD
- Surge arresters

**NOTE:** To make parallel connection between these three shelves, a BUS bar for AC IN, DC IN and AC OUT is available with CE+T as a separate kit (Part Number - P602006010). For more details about the connections, please refer to “16.4 Sierra-10-Parallel Kit 2/3 shelves (P602006010)”, page 49.

## 7. Installation of Sierra 10 - Shelf

- Read safety instructions prior starting any work.
- Do NOT attempt to use lifting eyes to erect the cabinet.
- System is preferable handled without modules.
- Pay attention to the module position, make sure that modules are repositioned in the same slot.
- In three phase systems, the modules are configured as per phase 1, phase 2 and phase 3.
- As long as the system is not in operation, make sure that modules from one phase are not mixed with modules from another phase. (When the system is running, modules can be moved from one phase to another without issue.)

### 7.1 Mounting kit for Sierra 10 - shelf

Sierra 10 - shelf mounting kit is designed to fix in different depth cabinets. The part number is **T319000001** and has the following accessories in the kit.

4 x Fixing brackets	2 x Sliders	8 x (M5 Philips head screws and nuts)
2 x (M6 Hex socket screws, cage nuts and nuts)		6 x (M6 Philips head screws and cage nuts)

**Perform the following steps to install the shelf mounting kit in the cabinet:**

1. Adjust the slider and brackets depending upon the cabinet depth, and fix it with M5 screws and nuts. If holes are available in the kit, fix it with the additional screws and nuts to increase the kit strength.
2. Place the assembled mounting kit in the cabinet and fix it on the front side at any one hole with the M6 Hex socket screw and cage nut. (Note: Tighten the Hex socket screw with Allen key till it touches behind the metal part.)
3. Fix the other end of the mounting kit at cabinet rear using the M6 Philips head screw and cage nut.
4. Similarly, assemble another mounting kit and fix it on another side of the cabinet.

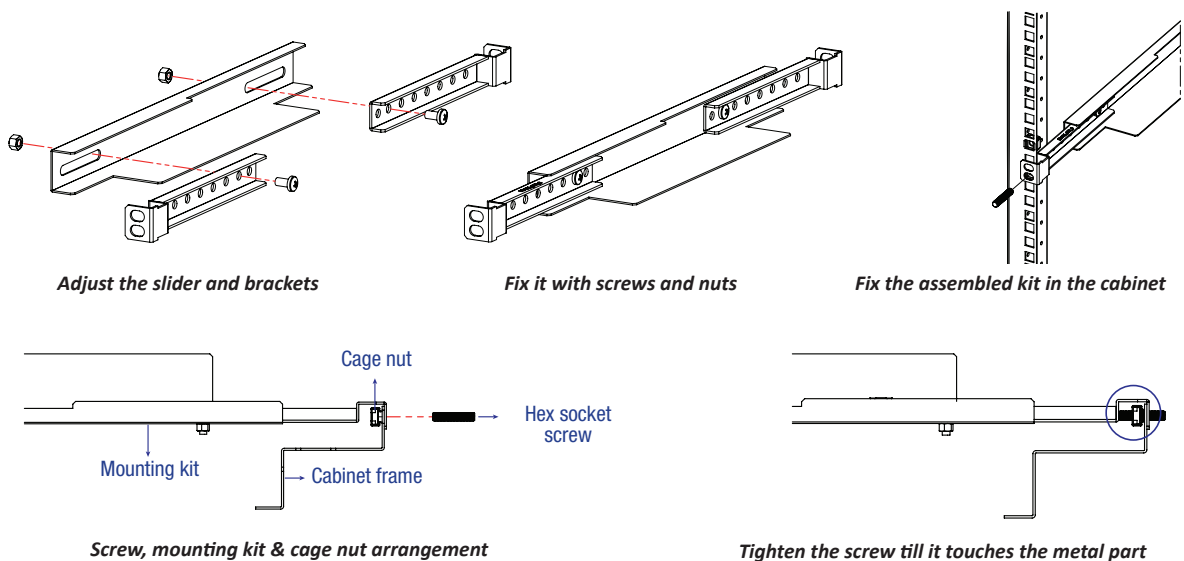

## Installation of Sierra 10 - Shelf

5. Place the shelf on the mounting kit and fix it with a M6 nut in the already installed hex socket screw used for the mounting kit.
6. Fix the other hole of the shelf in the cabinet using M6 Philips head screw and cage nut.
7. Similarly, fix the other side of the shelf and insert modules in the corresponding slot.

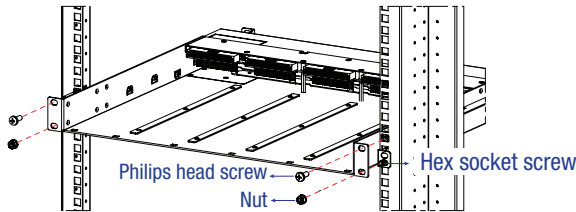

Place the shelf in the cabinet and fix it

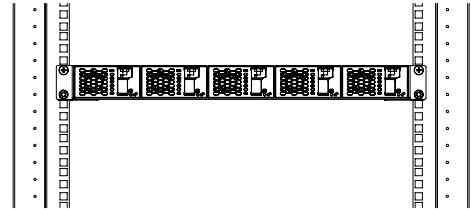

Insert the modules in the shelf

## 7.2 Electrical installation for Sierra 10 - shelf

### 7.2.1 Pre requisites

- The sub-rack have markings for all terminations.
- All cables shall be rated at Min 90 deg C.
- Electrical terminations shall be tightened with 5 Nm.
- All connection screws are M5 x 12 mm.
- DC Input / DC output - Common (per shelf), check DC polarity.
- AC Input / AC output - Common (per shelf), check AC phase angle.
- Wire all positions in the sub-rack for future expansion.
- Input AC / Output AC / Input DC / Signal cables shall be separated.
- Cable crossings shall be done in 90 deg angles.
- Empty converter positions shall be covered with dummy cover or module.

### 7.2.2 Terminations

The below image is termination details of Sierra 10 - 48/230 shelf.

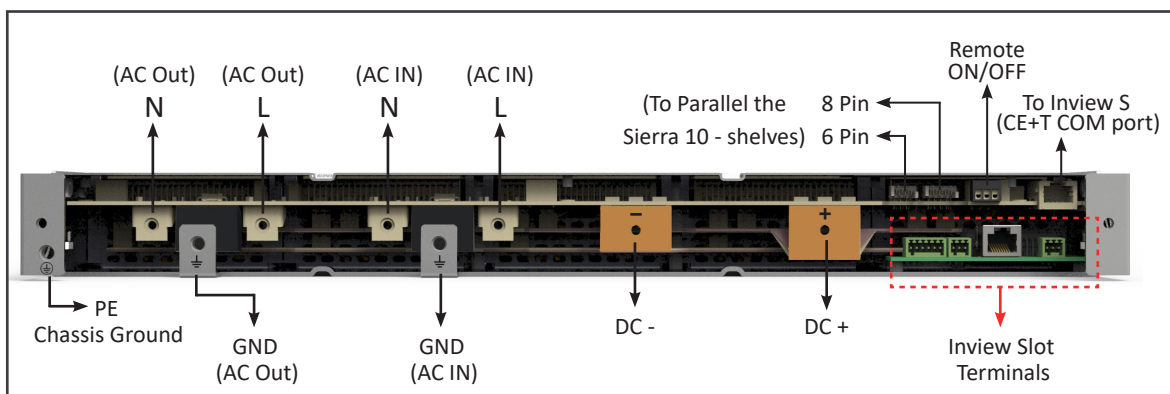

Sierra 10 - 48/230 - Shelf Rear Details

### 7.2.3 Cable Routing and Fixation

Terminations are present at rear side of the shelf and it is protected with IP 20 metal cover.

Perform the following steps to connect power and signal cables:

1. Remove rear protection cover by unscrewing two screws.
2. Break the required knock outs. **(Warning: Take special attention while breaking knockouts to avoid damaging the connectors, terminals and PCB in the shelf.)**
  - AC IN and OUT cables entry – Right end of the shelf (1 - Knock out)
  - DC and Signal cables entry – Left end of the shelf (2 - Knock outs)
  - Knock outs are also available at top and bottom of the protection cover.

*Note: Refer to section 16.3, page 48, to know more about knockout dimensions.*

3. Connect the power and signal cables with **supplied screws**, refer section 7.2.2, page 21 for terminals position.
4. Close the rear protection cover and tighten with two screws.

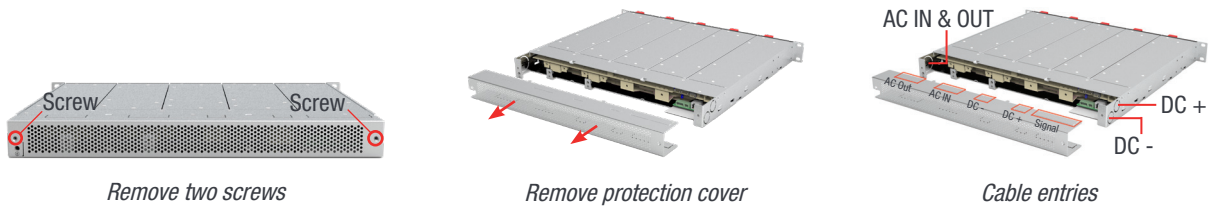

### 7.2.4 Grounding

“PE Chassis Ground”

PE Chassis ground should be wired to MET (Main Earth Terminal) or distributed earth bar connected to MET, according to local regulations.

### 7.2.5 DC

Model	MCB per Shelf	Cable, min	Lug	Torque
Sierra 10 - 48/230	125 A	50 mm <sup>2</sup>	Insulated Ring type	5 Nm

*Note: The Inner hole diameter of DC lug should be 6 mm (M6), and it is recommended to use only the supplied screws.*

### 7.2.6 AC Input

**WARNING !!!**  
 Recommendation of IEC 60364 4. 43

**431.3 Disconnection and reconnection of the neutral conductor in multi-phase systems**

Where disconnection of the neutral conductor is required, disconnection and reconnection shall be such that the neutral conductor shall not be disconnected before the line conductors and shall be reconnected at the same time as or before the line conductors.

**WARNING !!!**

**Input Neutral is required to operate the Converter, UPS**

In TN-S System no 4 pole input switch or circuit breaker shall be used. If you have to use 4 pole protective device, be aware that the neutral against the ground is floating. The converter, UPS will operate without problem but you may infringe the local regulation.

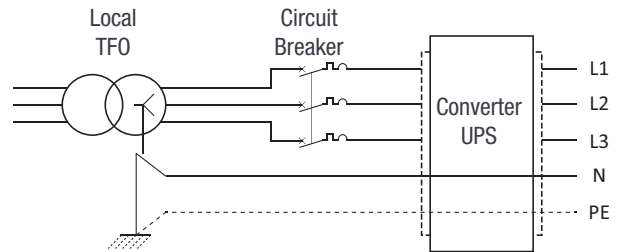

Model	MCB per Shelf	Cable, min	Connector	Lug	Torque
Sierra 10 - 48/230	40 A	6 mm <sup>2</sup>	M6	Insulated Ring type	5 Nm

Note: Icc value measured as 50 A<sub>rms</sub> per shelf with five modules.

### 7.2.7 AC Output

Model	MCB per Shelf	Cable, min	Connector	Lug	Torque
Sierra 10 - 48/230	32 A	6 mm <sup>2</sup>	M6	Insulated Ring type	5 Nm

### 7.2.8 Inview S with Sierra 10 System - Connections

1. Connect module shelf RJ45 port and Inview S CE+T COM port using RJ45 straight cable.
2. Connect Inview S CAN/iso RS485 port and Measure Box Battery CAN1 port using RJ45 straight cable.

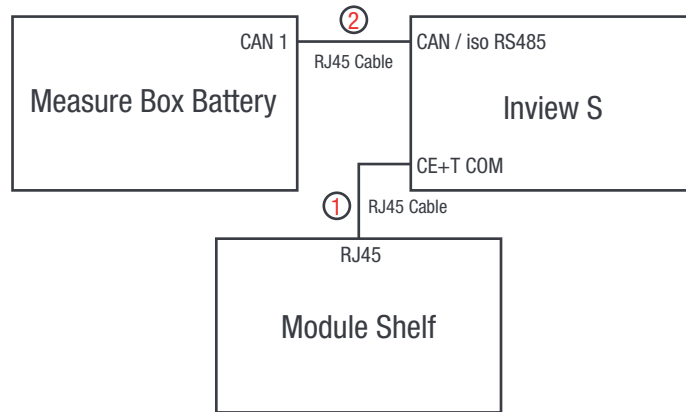

### 7.2.9 Signalling

Each shelf comprise of 8 and 6 pin connector, Remote ON/OFF and ETH port for communication. The PCB at the bottom of the rear shelf is for Inview Slot. It can only be accessed if Inview Slot connected to that shelf.

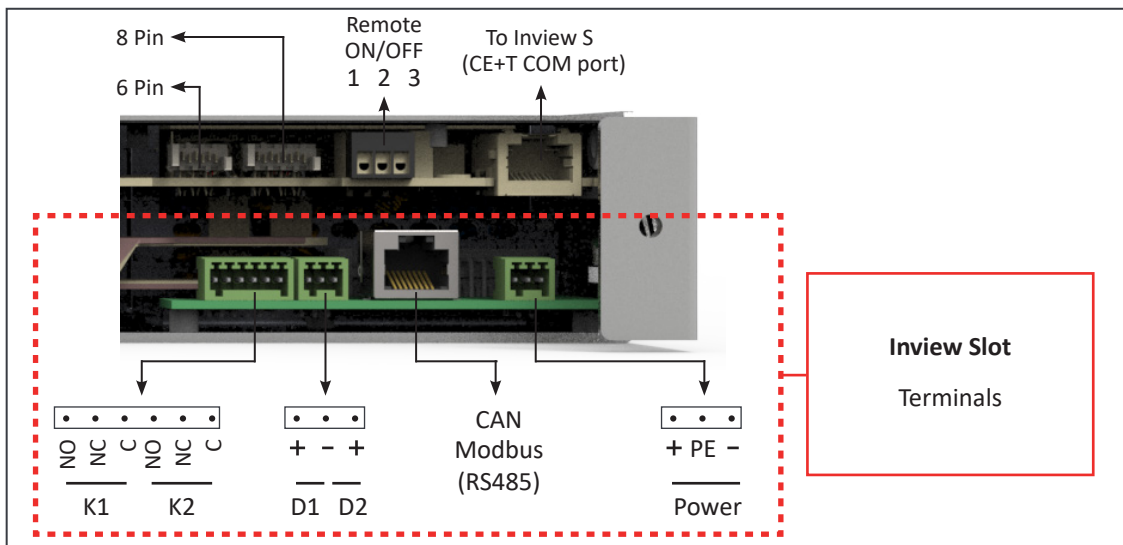

#### 7.2.9.1 Remote ON/OFF

The shelf is by default equipped with a connection between pin 3 and 2. If remote ON/OFF is not used the strap shall remain in all connected shelves. Should the remote ON/OFF be used, all straps must be removed and in one (1) shelf replaced with a changeover contact or emergency button.

- The remote ON/OFF switch the output AC OFF.
- Input AC and input DC is not affected by the remote ON/OFF.
- The remote ON/OFF can be connected to any shelf.



- The remote ON/OFF requires changeover contacts, one input opens as the other close.  
If both transitions are not picked up the status is not changed.

### Relay characteristics (Remote ON/OFF)

- Signal voltage +5 VDC (galvanic insulated)
- Max wire size 1 mm<sup>2</sup>

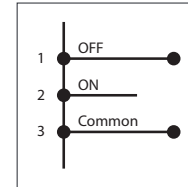

### Functional table for remote ON/OFF function

#	Pin 1-3	Pin 2-3	Status	Indication
1	Open	Open	Normal operation	All (Green)
2	Closed	Open	OFF	AC output (OFF) AC Input (Green) DC Input (Green)
3	Open	Closed	Normal operation	All (Green)
4	Closed	Closed	Normal operation	All (Green)

### Warning:

If remote ON/OFF is not used, pin 2 and 3 MUST be bridged together!

### 7.2.9.2 Internal bus (Bus 6 pin / Bus 8 pin)

- In a la carte system, the Internal bus is pre-installed and connected in series from the first shelf to last shelf.
- The internal bus is comprised of 6 and 8 pin CAN bus cables, and it is used to parallel if more than one shelf is present.
- If more than one shelf is ordered separately and installed in other cabinets, 6 and 8 pin connectors of each shelf should be looped with all the shelf using CAN bus cables.
- The internal bus connectors are sensitive and special caution should be taken during installation to keep them out of harm's way.

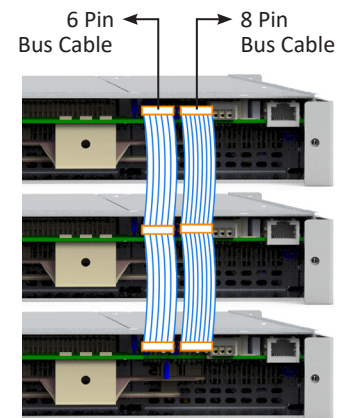

## 8. Interface

### 8.1 Converter module

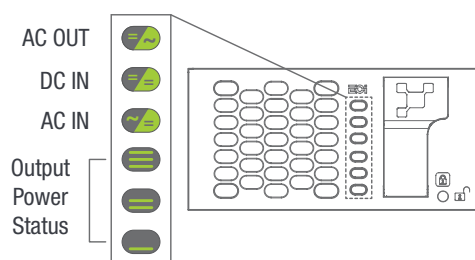

Converter Status LED	Description	Remedial action
OFF	No input power or forced stop	Check environment
Permanent green	Operation	
Blinking green	Converter OK but working conditions are not fulfilled to operate properly	
Blinking green/orange alternatively	Recovery mode after boost (10 In short circuit condition)	
Permanent orange	Starting mode	
Blinking orange	Modules cannot start	Check Inview
Blinking red	Recoverable fault	
Permanent red	Non recoverable fault	Send module back for repair

Output Power (redundancy not counted)						
<5%	5% to 40%	40 to 70%	80 to 95%	100%	100% = overload	Output Power (redundancy not counted)
×	×	×	≡	≡	≡	Status output power LED
×	×	≡	≡	≡	≡	
—	—	—	×	—	—	
1B	1P	2P	2P	3P	3B	Behaviour (B = Blinking, P = Permanent)

## 8.2 Inview S - LCD Display

Inview S LCD interface is a 2.8-inch touch screen. It does not have any user account, the user can only view the system details. The LCD interface is protected with the PIN during any action request.

Once system is powered upon, the Inview S is up and ready for operation.

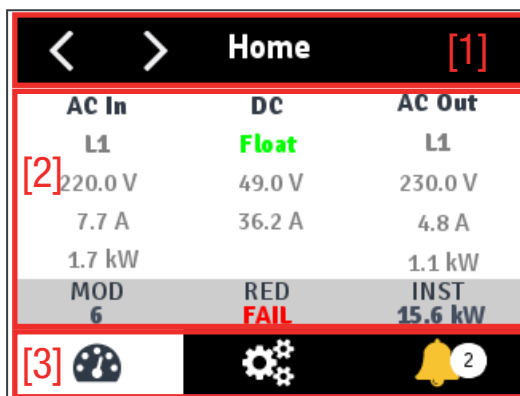

- **[1] Header**

Displays the title of the current page and navigation buttons for next and previous page. In some pages, Up and Down navigation buttons appear at the right side, indicating more contents are present.

- **[2] Information Area**

Provides information about the corresponding page.

- **[3] Toolbar**

The toolbar is present at the bottom throughout the interface, to provide quick access to following pages:

- Measures
- Settings
- Alarms and Logs

### 8.2.1 LED indications

Three LED's are present at front side of the controller to indicate major alarm, minor alarm, and system status

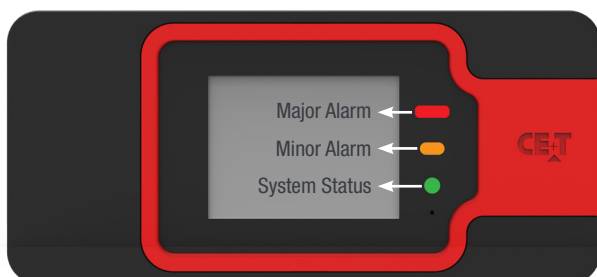

## 8.2.2 Menu structure

The home page is the default page in the LCD, and other pages display as below sequence in a circular list.

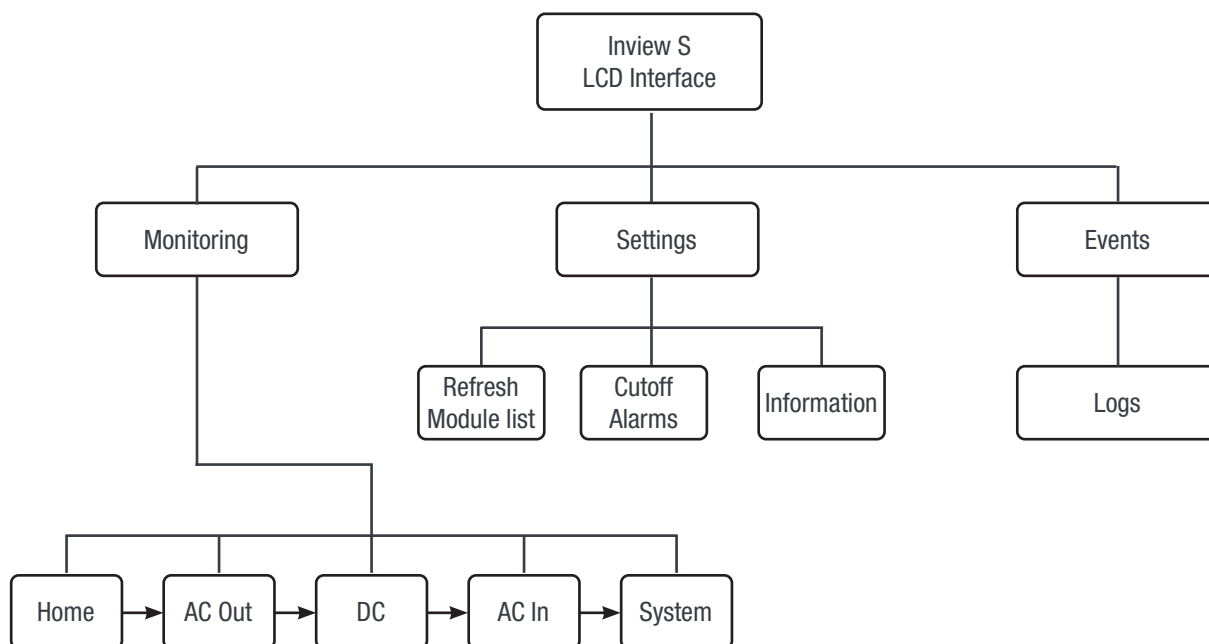

## 8.3 Inview Slot - LCD Display

Once the system is powered upon, the Inview Slot is up and ready for operation. The LCD is a 1.8-inch touch screen and user can only view the system details through the interface.

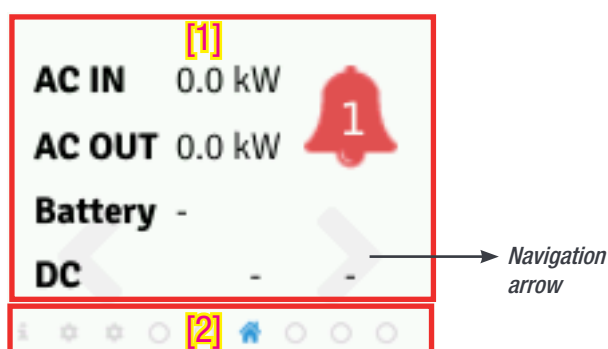

- **[1] Interface area**

Interface area provides information about the corresponding page. At the bottom of the screen, left and right arrows are present for moving next and the previous screen. In some screens, up and down arrows appear at the top of the page, indicating more contents are present

- **[2] Status bar**

The status bar appears throughout the interface and illuminate the current page icon.

### 8.3.1 LED indications

Three LED's are present behind the front black plastic of the controller to indicate major alarm, minor alarm, and system status. These LED's are not visible until they illuminate during the corresponding action occurs.

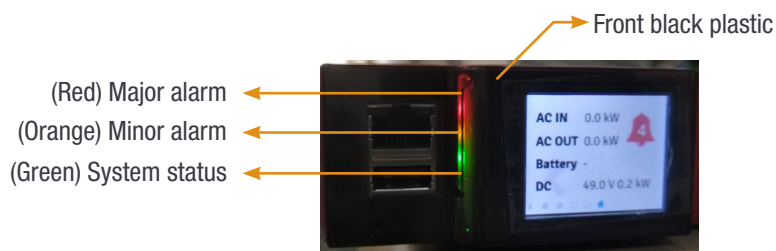

### 8.3.2 Menu structure

The home page is the default page in the LCD interface, and other pages are arranged in the below sequence.

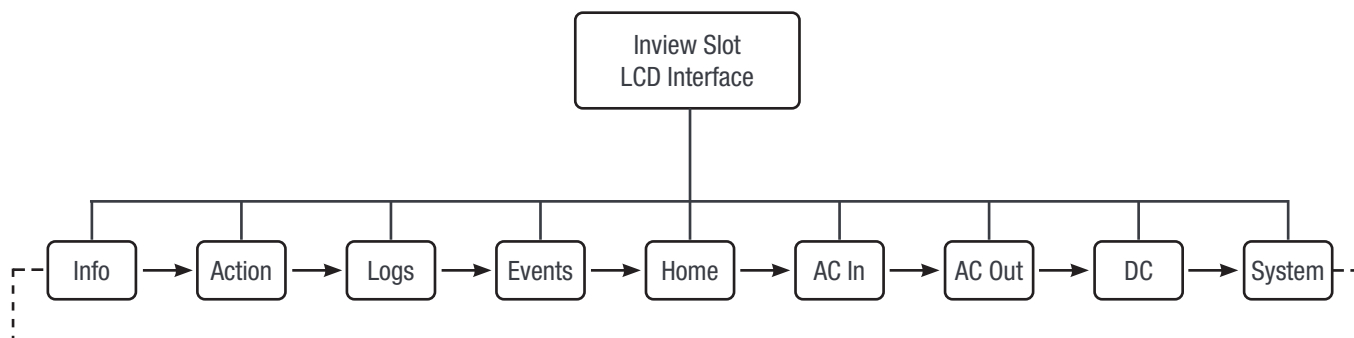

## 8.4 Inview S and Inview Slot - Web Interface

The web interface of both controller Inview S and Inview Slot is same, and the user can access the controller on the laptop through ETH port.

This section provides an overview of the web interface, refer Inview S user manual for detailed information.

### 8.4.1 Login

Open the web browser and type the default IP address **10.250.250.1** in the address field and press enter.

**Note:** Use any one of the following latest version of web browser: Google Chrome, Mozilla Firefox, Safari or Microsoft edge.

Inview S has three login – Basic, Expert and Admin. All three login is password protected.

The default password for all three logins is “1234”.

Basic login can only browse the pages and download the files, but Expert and Admin login can access and also modify the system parameter values.

An auto-logout feature is available to avoid a user being connected all the time. When no action is performed for more than **10 minutes**, the session will expire and goes to login screen.

### 8.4.2 Interface Areas

- 1 → Header
- 2 → Main Page

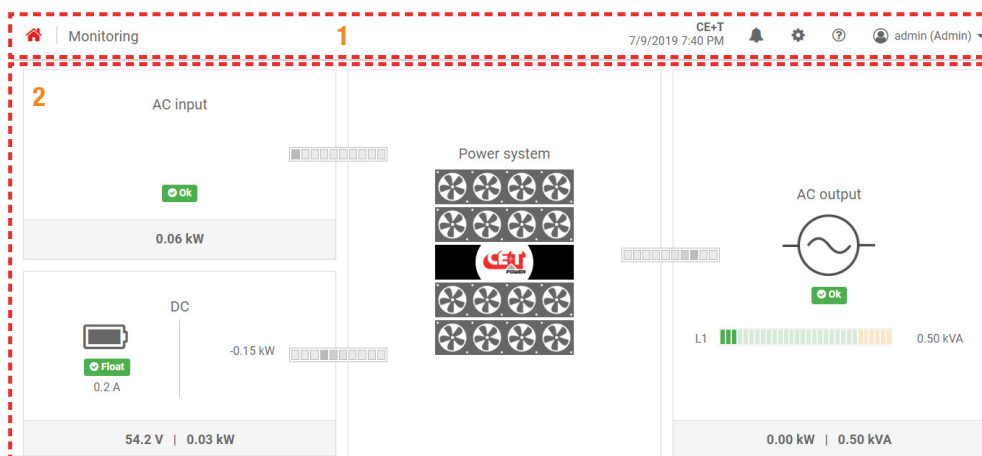

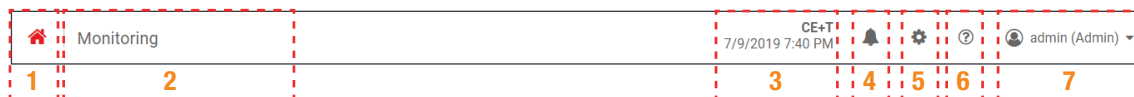

#### 8.4.2.1 Header



The tabs in header provide quick access to the corresponding pages.

- 1 → **Home:** Clicking on goes to the home page from any page you are accessing in the interface.
- 2 → **Breadcrumbs:** Provide navigation of the page. It trails all levels so that user can know where you are within the interface and can go to any previous menu.
- 3 → Display the date, time and the site name of the system.

- 4 → **Events:** Clicking on  goes to Events and Logs page.
- 5 → **Settings:** Clicking on  provide access to Users, Parameters and Maintenance pages.
- 6 → **Info:** Clicking on  in the home page, provides brief information about the system, while in other pages provide the latest three ongoing events.
- 7 → **Account:** Provides the information of which account is logged in (Basic, Expert or Admin). Clicking on drop-down arrow user can access the following pages:
  - **Administration** - Provide quick access to Users, Parameters and Maintenance pages. (Administration page will appear only in Expert login).
  - **About** - Provides the information of Inview product details and network connectivity details.
  - **Logout** - An act of logging out of an Inview S.

### 8.4.2.2 Home Page

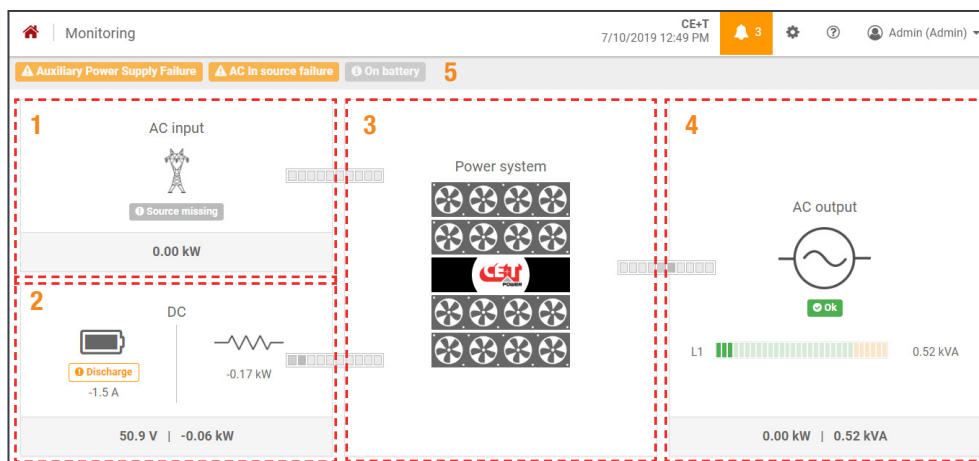

- 1 → **AC Input:** Clicking on the AC Input region displays the page contain all measurements regarding AC Input.
- 2 → **DC:** Clicking on the DC region displays the page contain all measurements regarding Battery and DC Output.
- 3 → **Power System:** Clicking on the Power System region display the page contain regarding system information such as overall system power and also in each phase, configured modules, active modules, and list of detected modules and accessories.
- 4 → **AC Output:** Clicking on the AC Output region displays the page contain all measurements regarding AC Output. Regardless of the system configuration (1P, 3P), display the power fed to the load on each phase.
- 5 → **Notifications:** Display the current generated alarms and events.

**Note:** To know more about Inview S and Inview Slot operation, refer to the Inview manual and it is available on request.

## 9. Replacement procedures

### 9.1 Module - Sierra 10

- The Sierra converter is hot swappable.
- When a new module is inserted in a live system it automatically adapts to a working set of parameters.
- When a new module is inserted in a live system it automatically assigns the next available address.

#### 9.1.1 Removal

**Notice:** When one or several converter modules is/are removed access to live parts becomes possible. Replace module(s) with dummy cover without delay.

1. Insert a soft edged pin into the hole to unlock the latch. (Hole diameter is 3 mm)
2. Push the pin and simultaneously pull the module using front handle.
3. Remove the module from shelf and replace with a new module or dummy cover.

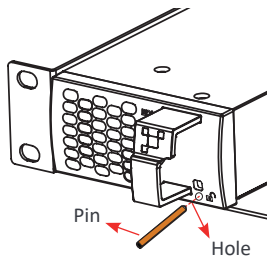

*Insert the pin into the hole*

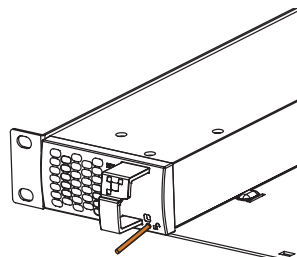

*Push the pin and pull the module*

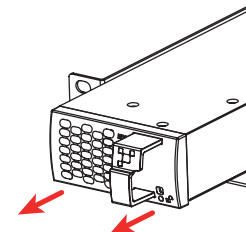

*Remove the module from shelf*

#### 9.1.2 Inserting

1. Check module compatibility (DC Voltage!).
2. Place the module and slide into the shelf.
3. Push the module firmly using the front handle, until the module rear is connected correctly with shelf.
4. Make sure the bottom latch in the module is locked in the shelf.
5. The module will start up and take the first address available on the bus.

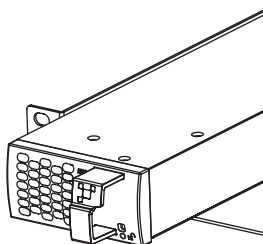

*Place the module & slide into the shelf*

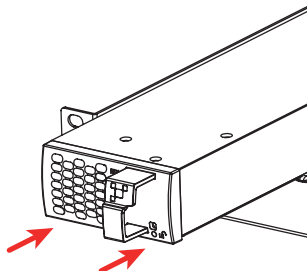

*Push firmly until module is engaged*

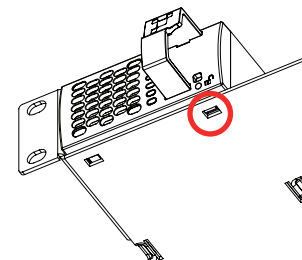

*Make sure the latch is locked in the shelf*



## 9.2 Controller - Inview Slot

### 9.2.1 Removal

1. Insert a soft edged pin into the hole to unlock the latch. (Hole diameter is 3 mm)
2. Gently push and press down the pin to unlock the latch and then remove the controller.

**Warning:** while removing the controller from the shelf, hold the top and bottom part of front plastic. Do not press on the touch screen.

3. Remove the controller from shelf and replace with a new unit or dummy cover.

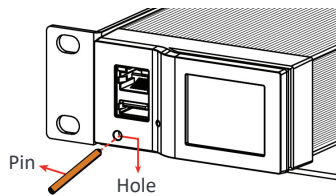

*Insert the pin into the hole*

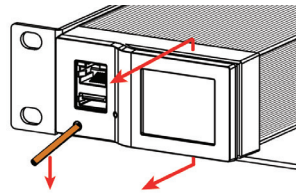

*Push and press down the pin, and pull the unit*

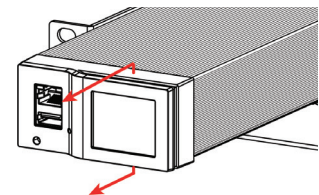

*Remove the module from shelf*

### 9.2.2 Inserting

1. Place the Inview Slot and slide into the shelf.
2. Push the unit firmly until the controller rear part is engaged correctly with shelf.

**Warning:** while inserting the controller into the shelf, push on the left side (ETH and USB port) of the controller. Do not press on the touch screen.

3. Make sure the latch is locked in the shelf.
4. The controller begins to start up and read the parameters from modules in the live system.

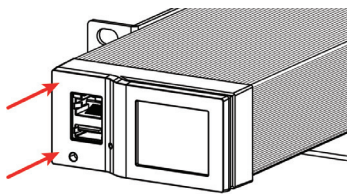

*Place the module & slide into the shelf*

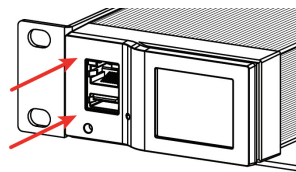

*Push firmly until unit is engaged*

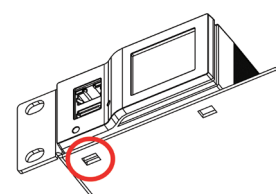

*Make sure the latch is locked in the shelf*

## 9.3 Controller - Inview S

### 9.3.1 Panel Mounting

Before mounting the Inview S in the system, route all the required connection cables from the system and place near to the Inview S mounting location.

1. Place the Inview S in the panel sheet.
2. Lock all the four latches at the rear side of the Inview S in the panel sheet.
3. Connect required connection cables to the Inview S.
4. Place the panel sheet in the system and fix it with screws

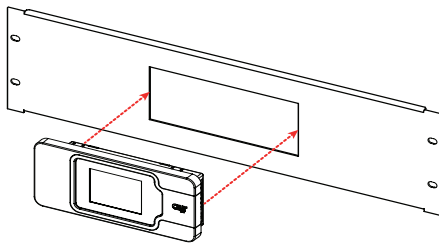

Place the Inview S in the panel sheet

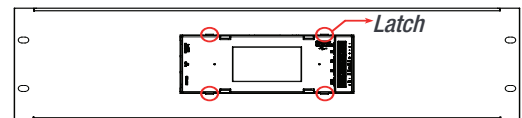

Fix it with four latches

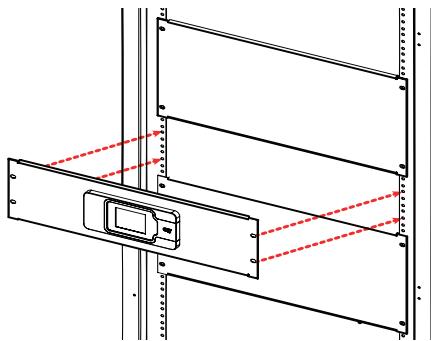

Connect wires and place the panel sheet in the cabinet

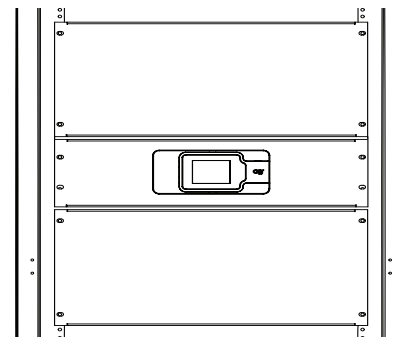

Fix the panel sheet with screws

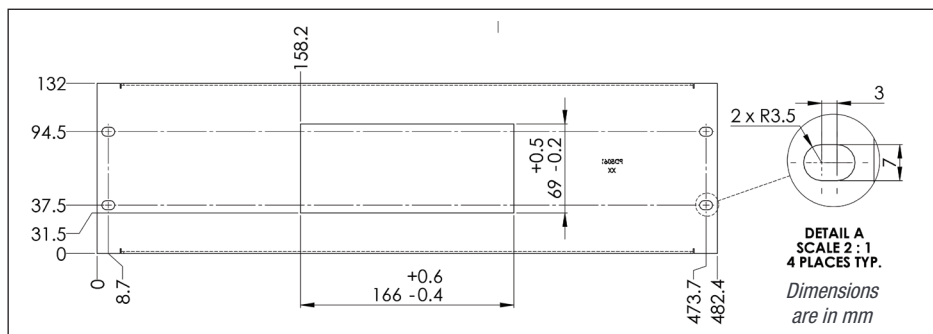

Panel sheet - cut-out details

## 9.4 Module Fan

The module's fan is speed control, and its speed varies depending upon the load percentage and module internal temperature. Its life is approximately 60,000 (Sixty Thousand) hours. The module has fan runtime meters and fans failure alarms, and the fan failure can result from a failing fan or driver circuit.

### 9.4.1 Fan Removal

1. Remove the module from the shelf and place it on the flat surface.

**Caution:** Prior to accessing the module, wait at least 5 minutes to allow internal capacitors to discharge.

*Note:* To remove the fan from the module, we need to remove the module front cover and bottom sheet.

2. To unlock the front cover, remove the screw at top of the module using Philips head screwdriver. But do not remove the cover.
3. Place the module upside down and remove the bottom sheet by removing 10 screws using a T6 screw driver. (8 screws at bottom sheet and 2 at rear). *Note:* Pay attention to the thermal pad, which stays on the transformer.

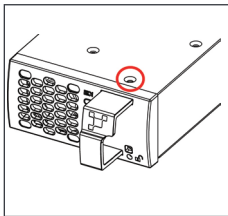

Remove the screw at top of the module

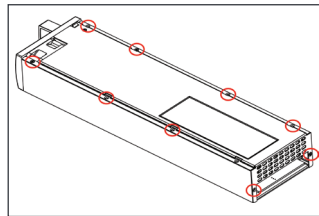

Remove the 10 screws at bottom sheet and rear

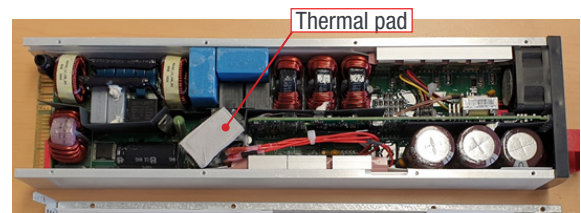

Pay attention to the thermal pad on the transformer

4. Remove the front cover with the fan by pulling horizontally (*Note the fan position on the front cover*).
5. Press firmly on the fan connector using a screwdriver, unlock it, and remove it from the board. (*Note the fan connector position and wire routing*).

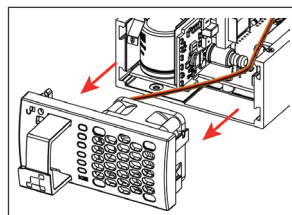

Remove the front cover with Fan

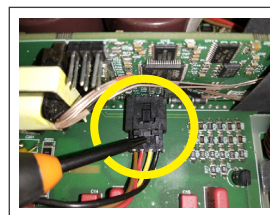

Press firmly and remove the Fan Connector

### 9.4.2 Fan Installation

1. Replace with the new fan in the front cover, and connect the fan connector to the board (Ensure the fan connector is placed correctly and followed the wire routing as it was before).
2. Place the front cover with the fan and fix the screw at the top of the module using a star screwdriver.

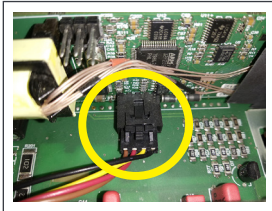

*Replace the new fan and  
Fix the connector*

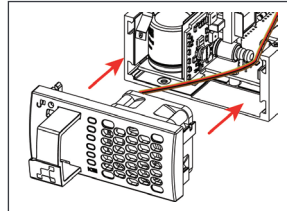

*Place the front cover with Fan*

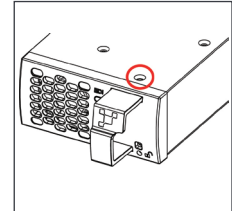

*Fix the screw at  
top of the module*

3. Make sure the thermal pad is placed correctly on the transformer.
4. Place the bottom sheet and pay attention to the Formex pass between the extruded housing and the components (especially Blue and Brown capacitors). Make sure it is easily supported on the extruded housing, and there is no bulging or warping.
5. Fix the bottom sheet by 10 screws using a T6 screw driver.



*Place the bottom sheet and  
pay attention to the Formex*



*No bulging and warping*

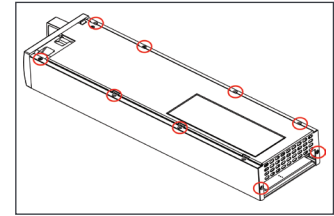

*Fix the 10 screws at  
bottom sheet and rear*

6. Place the module in corresponding slot and check the fan operation.
7. After replacing the new fan, reset the fan alarm. To do this, go to the corresponding module page on the web interface and click the "SET NEW FAN INSTALLED" button.
  - Module page in Inview SW 3.0: go to [Home page](#) > [Power system](#) and click the respective module from the list.
  - Module page in Inview SW 5.0: go to [Dashboard](#) > [Power system](#) and click the respective module from the list.

# 10. Manual By-Pass (Optional)

Manual By-Pass has to be operated by trained people only.

When system is in manual by-pass the load is subjected to mains voltage without active filtering. Output alarm is activated when system is in manual by-pass.

The Manual By-Pass cannot be operated remotely.

The Manual By-Pass can be integrated into the CE+T cabinet if requested at time of order. A Manual By-Pass purchased separately must comply with the instructions within section 10.3, page 38.

## 10.1 Pre-requisites

Commercial AC power must be present, and the converter must be synchronized with it, before operating MBP. The upstream commercial breaker must be correctly sized to accept the overload, and if the AC is supplied by a Gen-set, the minimal required power will be twice the nominal power of the converter.

The converter may be overloaded during the MBP procedure, depending on voltage network and output. Converter voltage setting: to reduce the impact of an overload, the converter power and current will be reduced from 150% to nominal value.

The by-pass switch disconnects all AC voltage on the shelves but has no effect on the DC feeding the converter and the remote alarm terminal.

**Note:** To limit the inrush current during Manual By-pass, CE+T recommends limiting the delta voltage between AC input / AC output to 5 Vac.

## 10.2 Manual By-Pass Operation

Manual Bypass operation creates a bypass from mains input via output AC distribution. Converter modules are bypassed and possible to disconnect without impacting the load.

Manual By-Pass operation is “Make before Break” logic.

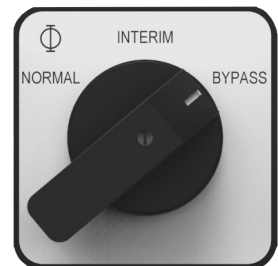

### 10.2.1 Normal to By-pass (Engage MBP)

1. Rotate the MBP Switch (S1) from **NORMAL** to **BYPASS**. **(Do not stop at INTERIM Position)**
2. Switch OFF the DC power and/or disconnect batteries..

**Manual By-Pass puts the module in OFF state but doesn't disconnect the DC. Make sure DC is disconnected before any intervention inside the system.**

**Warning: Risk of electric shock. Power will be available at AC Input terminal, AC Output terminal, DC Input terminal, and Surge Arresters.**

### 10.2.2 By-pass to Normal (Disengage MBP)

1. Switch ON the DC power and/or connect batteries, and wait for module DC IN LED to turn green.
2. Rotate the MBP Switch (S1) from **BYPASS** to **INTERIM**.  
(Wait until the modules turn on and synchronized, approximately 30-60 seconds).
3. Rotate the MBP Switch (S1) from **INTERIM** to **NORMAL**.

**WARNING**

IF ATS (automatic transfer switch) IS INSTALLED UPSTREAM TO SELECT AC SOURCE. MAKE SURE THAT THE ATS SWITCH DOES NOT ALLOW TRANSFER BETWEEN AC SOURCE OUT OF SYNC. THE MAXIMUM ALLOWED PHASE SHIFT IS 10°.

### 10.3 MBP Auxiliary connection

If manual by pass (Single rotary switch) is installed in the system and its auxiliary should be wired as per the following:

Note: The below connection is for a sub-rack system, and auxiliary (Aux) number varies depending upon the MBP switch. So it is recommended to refer the technical sheet received along with the system.

- Connect Aux3 of MBP to Digital Input 01 of the controller. So that the controller gets information when MBP is engaged. (The digital input terminal of Inview Slot is present at rear side of the shelf).
- Connect Aux1 and Aux2 of MBP to Remote ON/OFF terminal in the shelf where controller is installed.

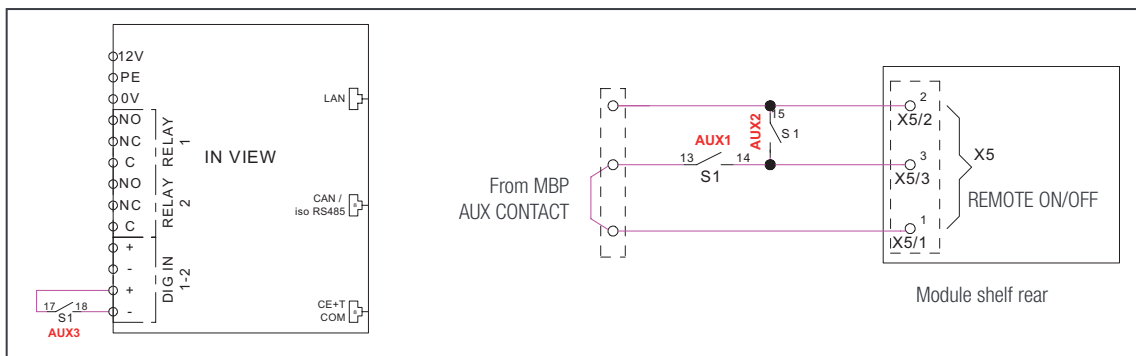

MBP auxiliary connection in Inview S

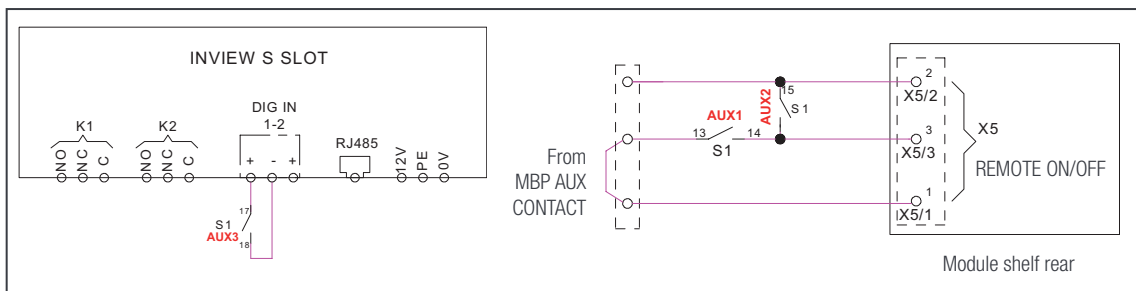

MBP auxiliary connection in Inview Slot

The Digital Input Mode must configure as below through web Interface :

- Inview Ver-3: IVS- DI1 mode → “Manual Bypass state detection”
- Inview Ver-5: DI1 mode → “conv51\_Manulbypass”

## 11. Finishing

---

- Make sure that the sub-rack/cabinet is properly fixed to the cabinet/floor
- Make sure that the sub-rack/cabinet is connected to Ground.
- Make sure that all DC and AC input breakers are switched OFF.
- Make sure that all cables are according to recommendations and local regulations.
- Make sure that all cables are strained relieved.
- Make sure that all breakers are according to recommendation and local regulations.
- Make sure that DC polarity is according to marking.
- Re tighten all electrical terminations.
- Make sure that no converter/controller positions are left open.
- Cover empty converter positions with dummy cover.
- Make sure that the Remote ON/OFF is appropriately wired according to local regulations.
- Make sure that the point of AC supply meets local regulations.

## 12. Commissioning

---

The DC breaker is a protection device. Modules are plugged in a system and DC breaker is then engaged. Please make sure the corresponding DC breaker is engaged in the ON position. Failure to observe this rules will result not to have all module operating when running on DC and have module failure when AC input recover from fault condition.

Installation and commissioning must be done and conducted by trained people fully authorized to act on installation.

It is prohibited to perform any isolation test without instruction from manufacturer.

Equipments are not covered by warranty if procedures are not respected.



## 12.1 Check list

DATA	
Date	
Performed by	
Site	
System serial number	
Module serial numbers	
Inview Serial number	
ACTION	OK/ N.OK
Unplug all converters except one converter per phase (Just pull off the converter from the shelf, to interrupt electrical contacts)	
Check the commercial AC before closing the AC input breaker.	
Switch ON the commercial AC	
Check if converters are working (Green led)	
Check the DC power supply and switch ON the DC breakers	
Plug in all converters one by one	
Check output voltage (on bulk output or on breaker)	
Check if converters are working properly	
Check if system has no alarm (Disable the alarm if any)	
Read configuration file and review all parameters. Some parameters must be adapted according to the site (LVD, load on AC, AC threshold level)	
Switch OFF ACin and check if system is working on DC	
Switch ON ACin and check if system correctly transferred load on AC	
Switch OFF system and start on AC only	
Switch OFF system and start on DC only	
Check if display working properly (Inview)	
Check if TCPIP working properly (if this option is present)	
Test on load (if available)	
ALARM	
Switch ON AC input and DC input and check that no alarm are present	
Pull out one converter and check alarm according to redundancy	
Pull out two converters and check alarm according to redundancy	
Switch OFF AC input (commercial power failure) and check the alarm according to the configuration	
Switch OFF DC input (DC power failure) and check that the alarm according to the configuration	
Check the different digital input according to the configuration (when used)	





## 13. Trouble Shooting and Defective Situations Fixing

### 13.1 Trouble Shooting

Converter module does not power up:	<ul style="list-style-type: none"><li>Check AC input present and in range (AC breakers)</li><li>Check DC input present and in range (DC breakers)</li><li>Check that the converter is properly inserted</li><li>Remove converter to verify that slot is not damaged, check connectors</li><li>Check that module(s) is (are) in OFF state</li><li>Check for loose terminations</li></ul>
Converter system does not start:	<ul style="list-style-type: none"><li>Check that Inview is present and properly connected</li><li>Check remote ON/OFF terminal</li><li>Check the configuration and setting</li><li>Check threshold level</li></ul>
Converter only run on AC or DC:	<ul style="list-style-type: none"><li>Check AC input present and in range (AC breakers)</li><li>Check DC input present and in range (DC breakers)</li><li>Check the configuration and setting</li><li>Check threshold level(s)</li></ul>
No output power:	<ul style="list-style-type: none"><li>Check output breaker</li></ul>
All OK but I have alarm:	<ul style="list-style-type: none"><li>Check the type of event and log file in the controller</li></ul>
No alarm:	<ul style="list-style-type: none"><li>Check relay delay time of alarms in the controller</li><li>Check configuration file</li></ul>

### 13.2 Defective modules

- A repair request should follow the regular logistics chain:  
End-user => Distributor => CE+T Power.
- Before returning a defective product, a RMA number must be requested through the <http://my.cet-power.com> extranet. Repair registering guidelines may be requested by email at [repair@cet-power.com](mailto:repair@cet-power.com).
- The RMA number should be mentioned on all shipping documents related to the repair.
- Be aware that products shipped back to CE+T Power without being registered first will not be treated with high priority! (Label shown here is only for representation)

<b>SIERRA 10-48/230 MODULE ECI</b>		
P/N: T711730201 S/N: 000111		
DC Input/Output: --- 48 Vdc (40-60)/22.8A		
AC Input ~ 230 V (185-265)/ 5.6A 50/60Hz		
AC Output ~ 230 V /5.4A 50/60Hz		
Output power 1kW/1.25kVA		
		
BURN IN STAMP 05/19 		
MADE IN BELGIUM		

# 14. Maintenance

---

Maintenance should be performed by properly trained people.

## 14.1 Access Inview with Laptop

- Download system LOG FILE and save
  - Analyze log file and correct errors
- Download system CONFIGURATION FILE and save
  - Check/correct configuration file according to operation conditions
  - Check/correct alarm configuration
- Check module internal temperature for deviation between modules
  - Temperature deviation may indicate build up of dust. Clean the module by air suction blower or vacuum cleaner.
- Check module/system load
- Check/Correct converter mapping (DC group/AC group/ Address)

## 14.2 Manual check

- Check voltages of AC input, DC input, AC output and DC output using the multi-meter
- Replace door filter if more dust is accumulated.
- Take a snap shot of the cabinet and site condition

## 14.3 Optional

- With an infrared camera check termination hot spots
  - Tighten terminations

## 14.4 Manual By-Pass

- Make sure AC input source is available during MBP operation. Otherwise the LOAD will be affected.

## 15. Service

---

### For Service

- Check Service Level Agreement (SLA) of your vendor. Most of the time they provide assistance on call with integrated service. If such SLA is in place, you must call their assistance first.
- If your vendor doesn't provide such assistance (\*) you may contact CE+T through email: [customer.support@cet-power.com](mailto:customer.support@cet-power.com)

(\*) CE+T will redirect your call to your vendor if he has such SLA in place.

# 16. Appendix

## 16.1 Mains connection - Single phase

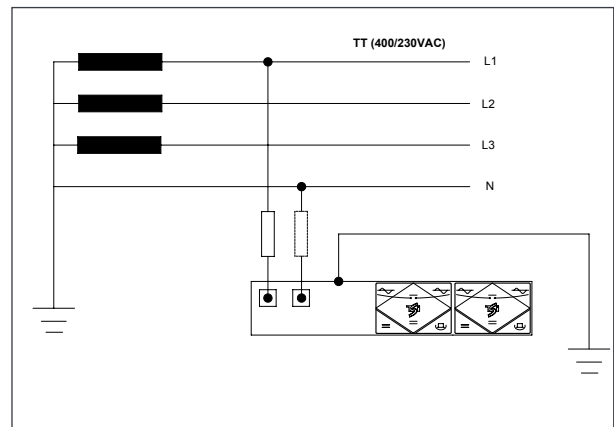
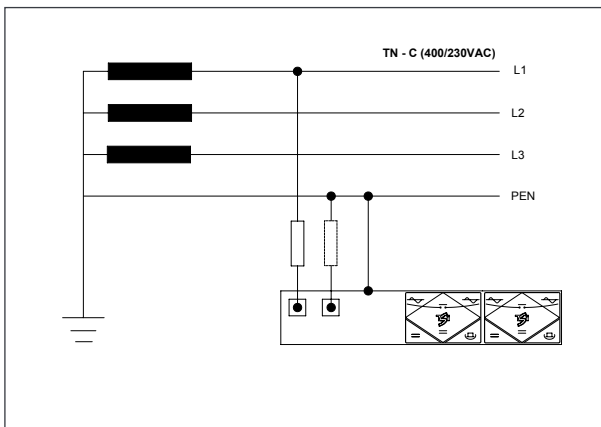
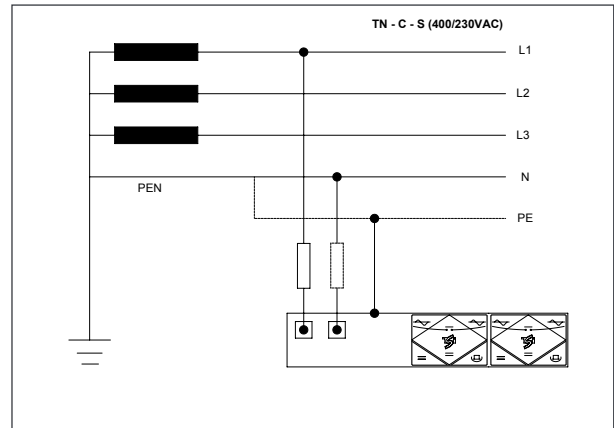
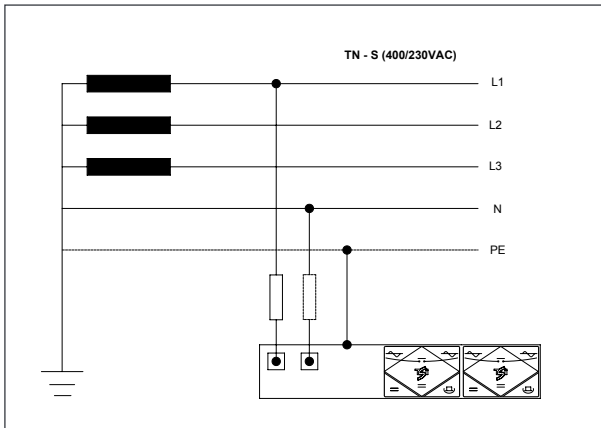

## 16.2 Mains connection - Three phases

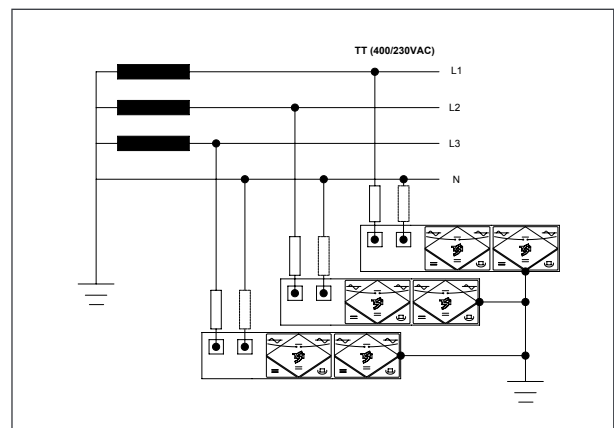
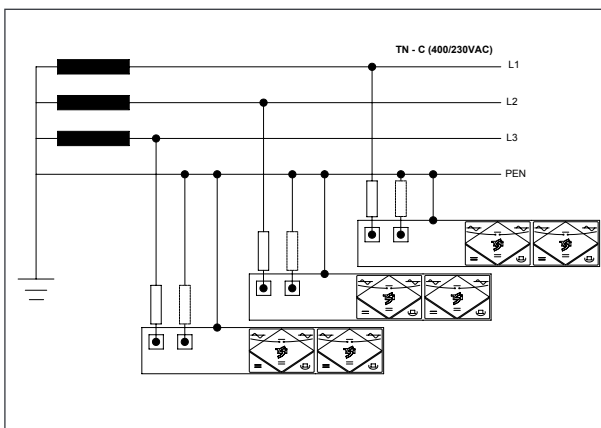
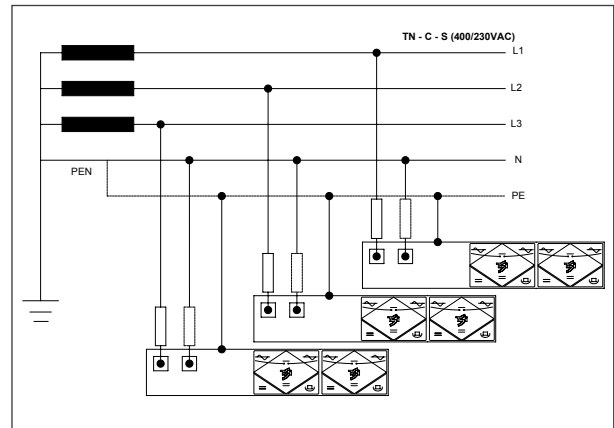
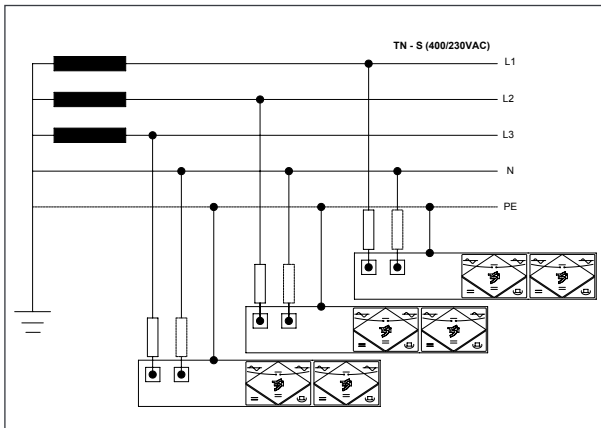

## 16.3 Sierra 10 - 48/230 - Dimensions

### 16.3.1 Module

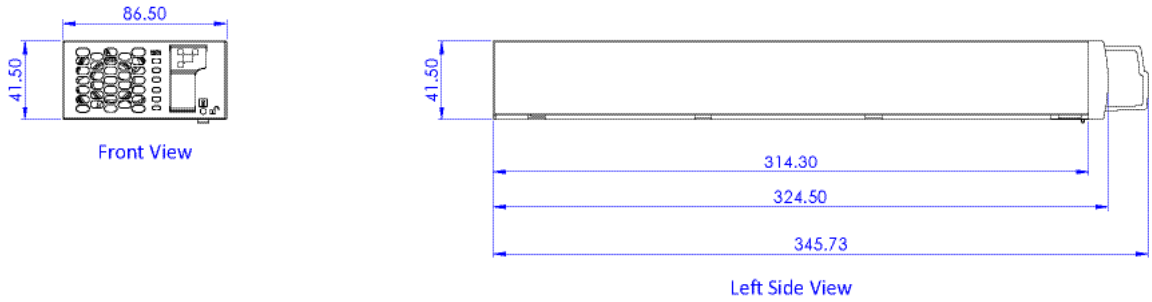

### 16.3.2 Shelf

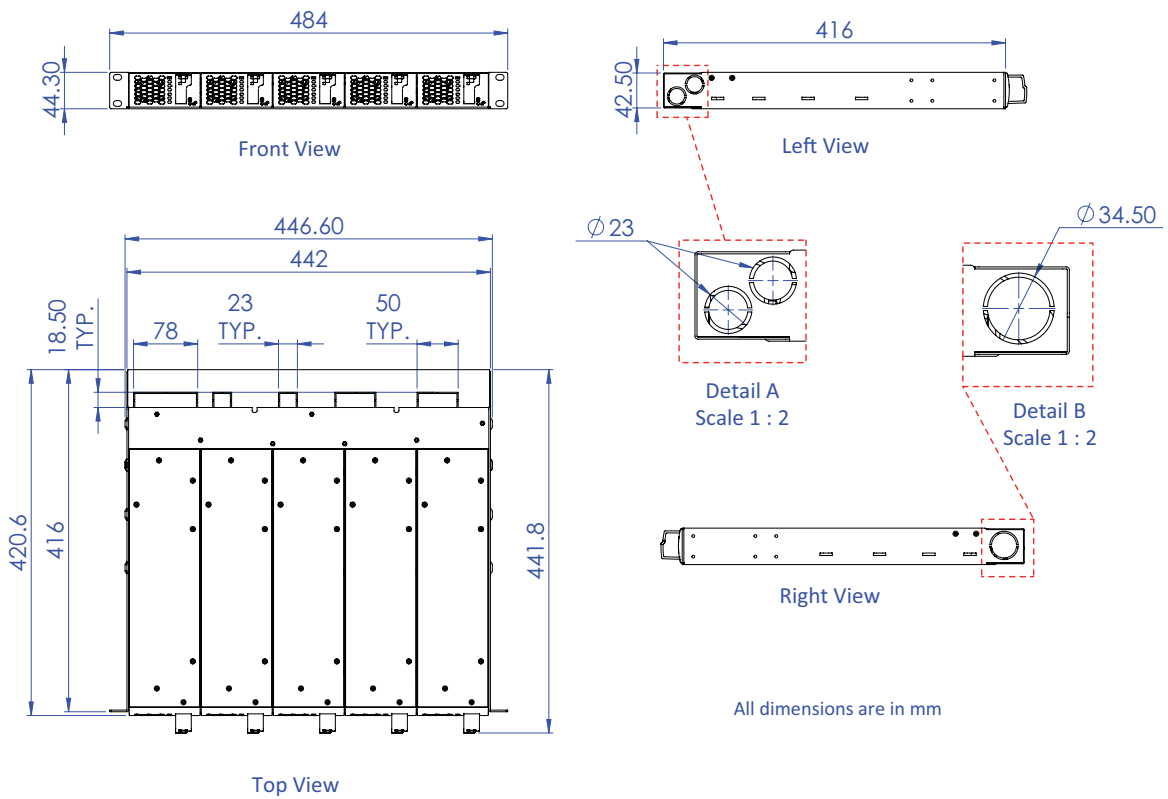



## 16.4 Sierra-10-Parallel Kit 2/3 shelves (P602006010)

The purpose of the kit is to parallelize the Sierra/Bravo 10 shelves (2 or 3 shelves only) in a 1-PH configuration or 3-PH configuration (3-PH configuration is only available with 3 shelves).

- To parallelize 2 Shelves, use one kit P602006010
- To parallelize 3 Shelves, use two kits P602006010

Each kit contains:

- DC Busbar\_PD5446\_Art.no 2399054460 (2 Nos)
- AC Busbar\_PD5472\_Art.no 2399054720 (4 Nos)
- Bus cable 3 shelves (P324730303) (1 No)
- Screws (M6x16) with Spring & Plain Washers (6 Nos)
- HEX Head Bolt (M6x16) with spring washer (2 Nos)

*NOTE: M6x12 bolts are available in the shelf by default.*

### 16.4.1 Bus Cable Installation:

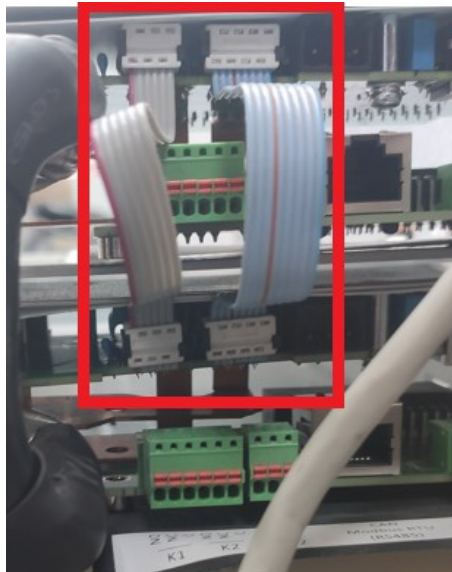

A communication cable has to be connected on the rear side of the Shelf.

*Note: for 2 shelves configuration, the third connector has to be protected/isolated properly.*

16.4.2 DC Copper Bar Positioning:

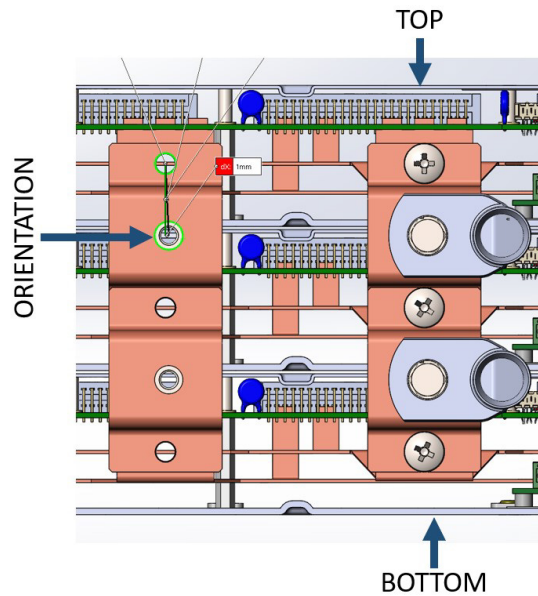

Note:

For orientation of the Connecting copper bar, follow similar position (hole offset) as in the above picture (for additional lug spacing).

16.4.3 Copper bar placement, cables connection and screws adaptation:

It is important to respect screws and cable lug position as defined below. Screws size have been adapted taking into account copper bar and lugs in order to ensure connections and respect dielectric distances.

16.4.3.1 3 Shelves Configuration – 3 Ph:

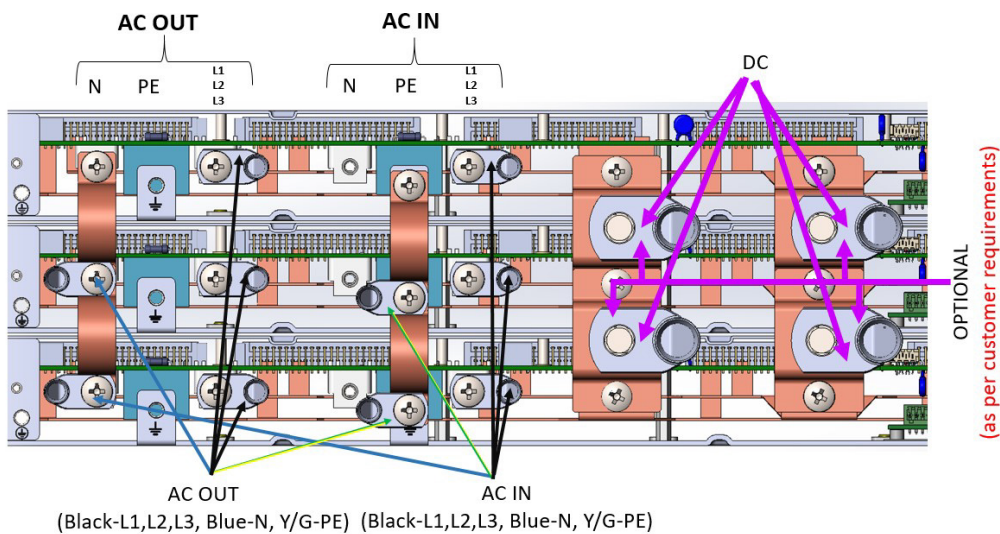

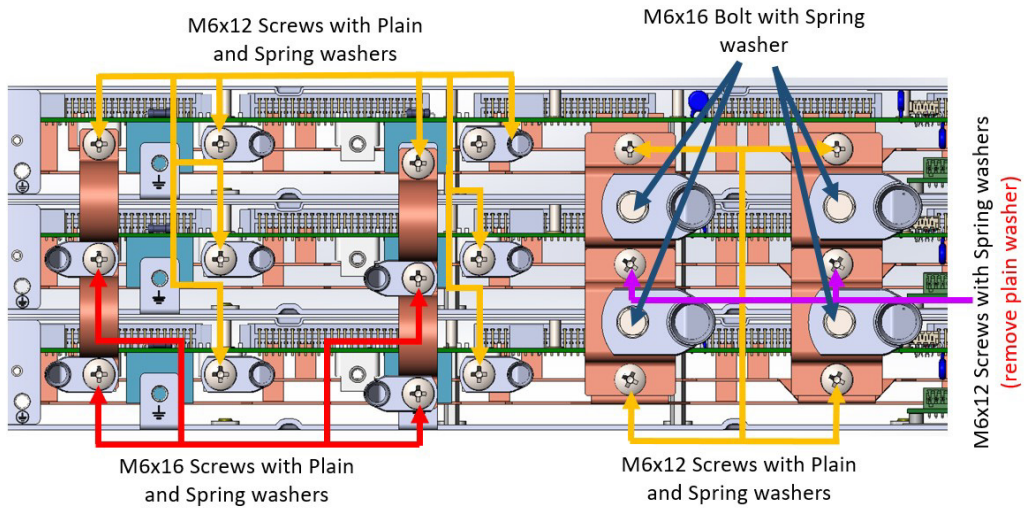

16.4.3.2 3 Shelves Configuration – 1 Ph:

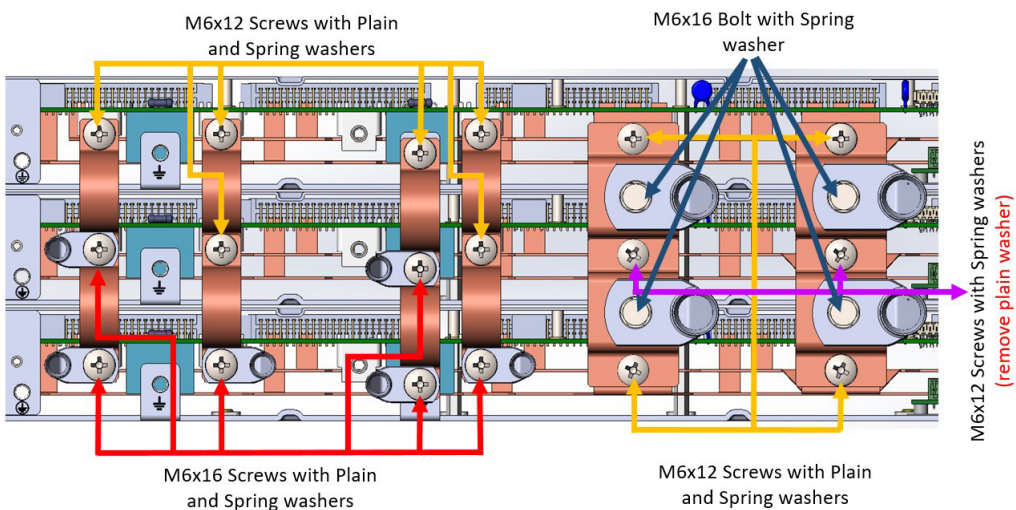
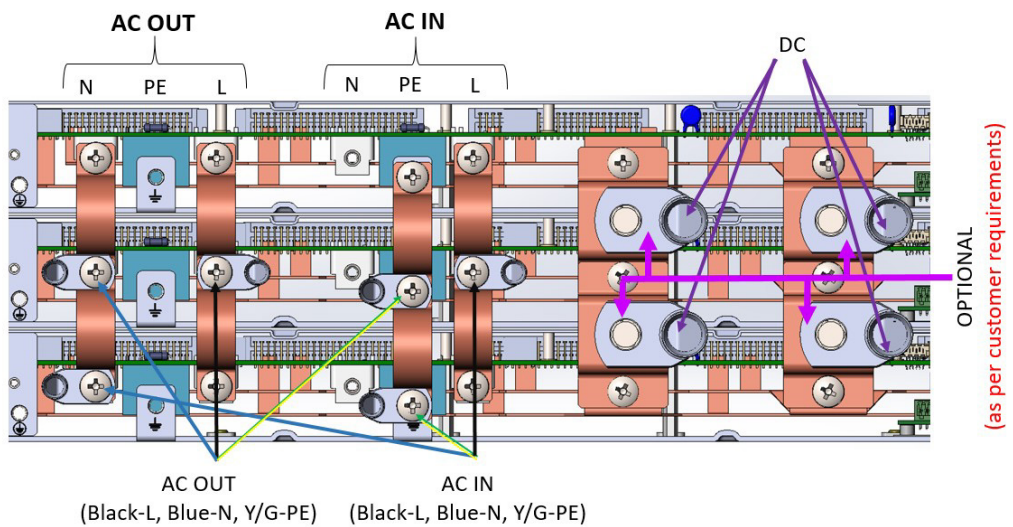

## 16.4.3.3 2 Shelves Configuration – 1 Ph:

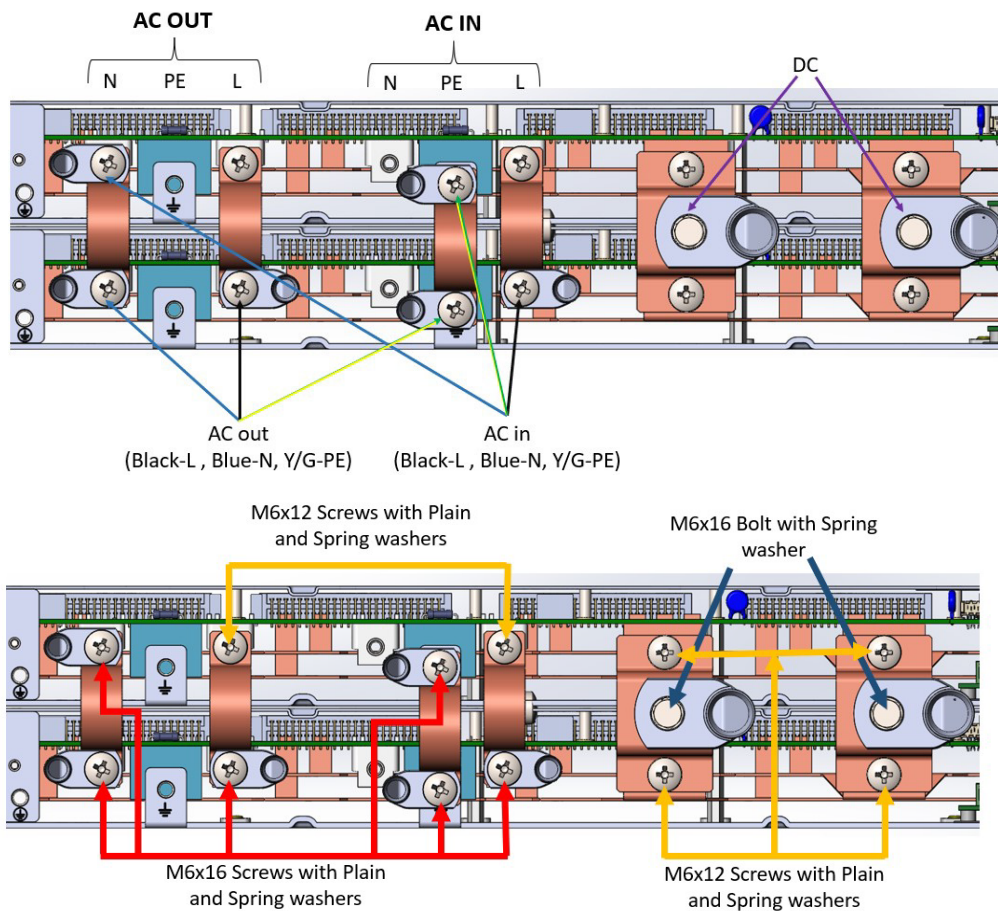
**Note:**

AC & DC cable connection from customer side to the system shall be with proper cable & lug based on the power rating. The Lug size must be M6.

Once the above assembly procedures are completed, Sierra/Bravo 10 modules can be plugged into the shelf.

For further queries, contact [@customer.support@cet-power.com](mailto:customer.support@cet-power.com).

### 16.5 Inview S with MBB - Wiring diagram

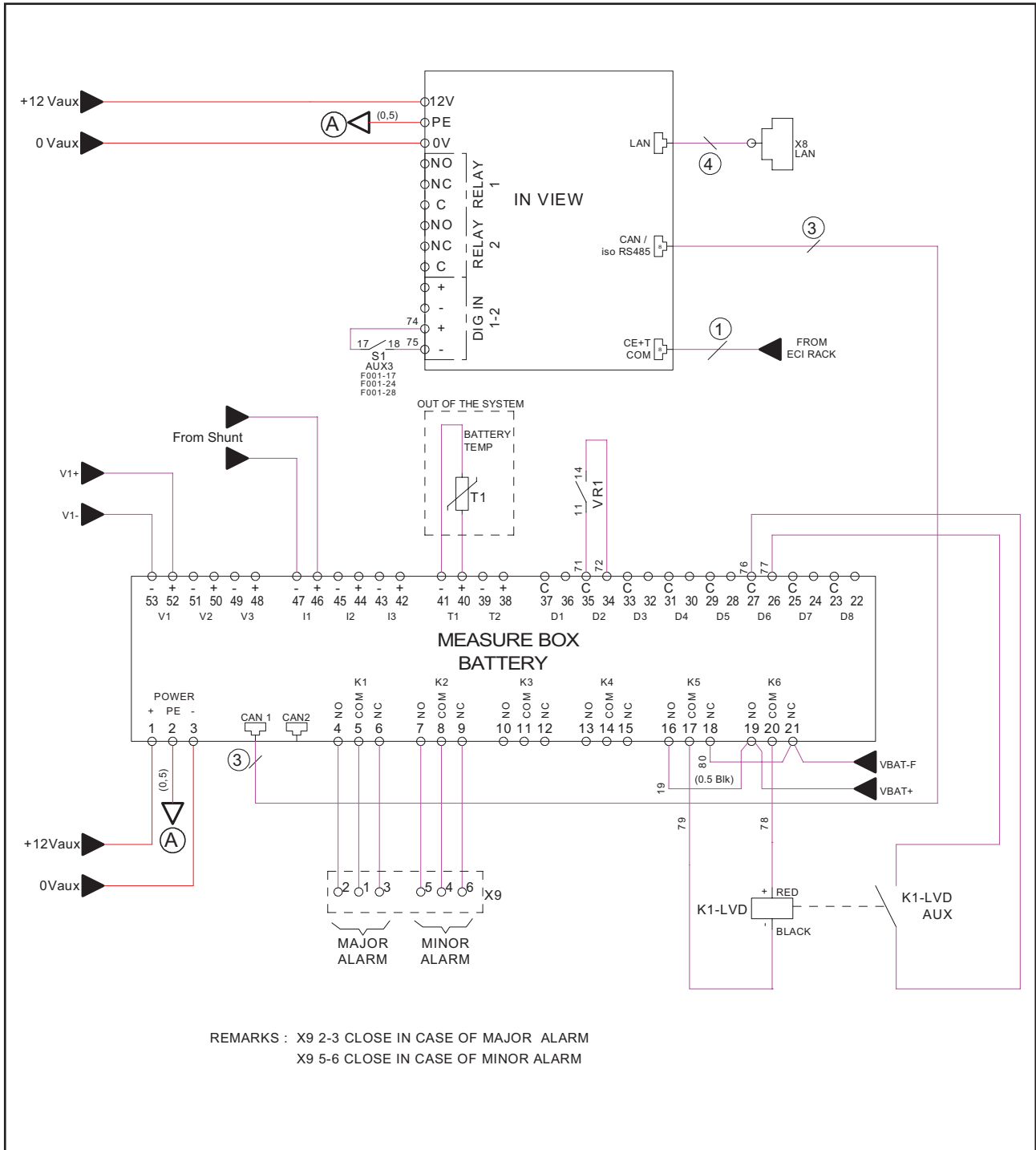

### 16.6 Inview Slot with MBB - Wiring diagram

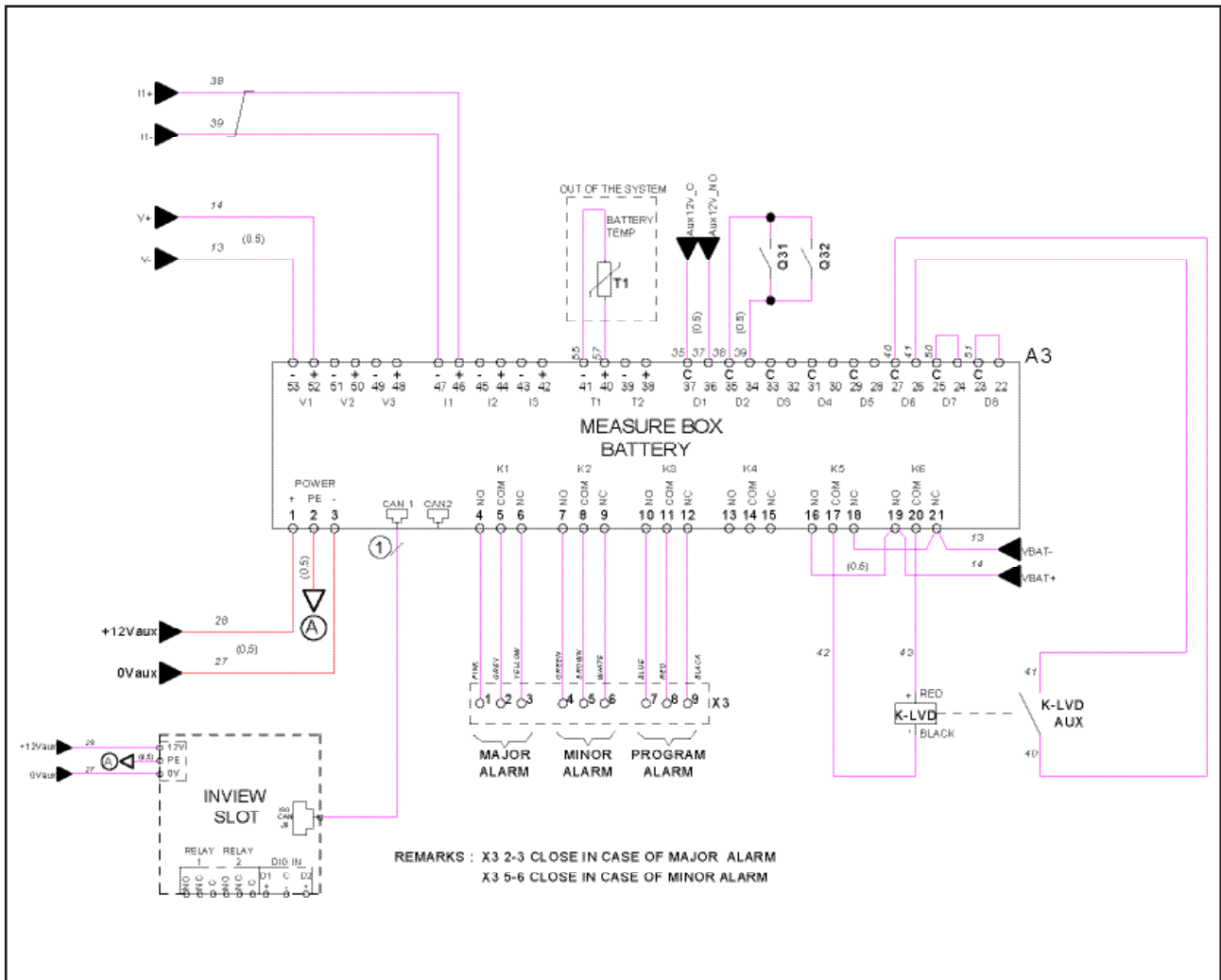

## 16.7 Modules - Parameter List

Parameter	Description	Min	Default	Max	Unit
V DC in low start - dV (000)	Low DC Voltage where a higher value leads the DC/AC converter to re-start	390	440	610	dV
V DC in low transfer - dV (001)	Low DC Voltage where a lower value leads to transfer the load from DC IN to AC IN. Under this voltage peak-shaving is relaxed and battery discharge test is stopped.	390	390	610	dV
V DC in low stop - dV (002)	Low DC voltage where a lower value stops the DC/AC converter	390	390	610	dV
V DC in high start - dV (003)	High DC voltage where a higher value re-starts the DC/AC converter	390	580	610	dV
V DC in high transfer - dV (004)	High DC Voltage where a higher value leads to transfer the load from DC IN to AC IN	390	610	610	dV
V DC in high stop - dV (005)	High DC voltage where a higher value stops the DC IN converter. Value increased from sw 173 to 62 VDC	390	610	610	dV
V AC in low start - dV (006)	AC IN Voltage where a higher value leads the AC IN to start	1950	1950	1950	dV
V AC in low transfer - dV (007)	AC IN Voltage where a lower value leads to the transfer of the load from the AC IN to DC IN	1850	1850	1850	dV
V AC in low stop - dV (008)	AC IN Voltage where a lower value leads the AC IN converter to stops. It is possible to step down to 150 Vac. In this case, the AC/DC converter will run at a lower power. The converter DC/DC supply the rest (ONLY if DC is available, if not, there is a de-rating)	1820	1820	1820	dV
V AC in high start - dV (009)	AC IN Voltage where a lower value leads the AC IN converter re-start	2550	2550	2550	dV
V AC in high transfer - dV (010)	AC IN Voltage where a higher value leads to the transfer the load of the charge from the AC IN converter to the DC IN converter	2600	2600	2600	dV
V AC in high stop - dV (011)	AC IN Voltage where a higher value leads to stop the AC IN converter	2650	2650	2650	dV
F AC in low start - cHz (012)	Frequency where a higher value leads the outlet of the converters trying to synchronize with AC IN	4700	4730	6300	cHz
F AC in low stop - cHz (013)	Frequency where a lower value leads the outlet of converters stop to synchronize with AC IN	4700	4700	6300	cHz
F AC in high start - cHz (014)	Frequency where a lower value leads the converters outlet to synchronize with AC IN	4700	5270	6300	cHz

Parameter	Description	Min	Default	Max	Unit
F AC in high stop - cHz (015)	Frequency where a higher value leads the converters outlet to stop to synchronize with AC IN	4700	5300	6300	cHz
Free running frequency - cHz (016)	Set the Converters system frequency. This frequency is used when the system is not synchronized on AC input.	-	5000	-	cHz
Out 1 phase shift - deg (018)	Phase displacement.	0	0	360	Deg
Out 2 phase shift - deg (019)		0	120	360	Deg
Out 3 phase shift - deg (020)		0	240	360	Deg
Out 4 phase shift - deg (021)		0	0	0	Deg
Out 5 phase shift - deg (022)		0	0	0	Deg
Out 6 phase shift - deg (023)		0	0	0	Deg
Out 7 phase shift - deg (024)		0	0	0	Deg
Out 8 phase shift - deg (025)		0	0	0	Deg
Out 1 nominal voltage - dV (026)	Set output voltage for each phase.	2000	2300	2450	dV
Out 2 nominal voltage - dV (027)		2000	2300	2450	dV
Out 3 nominal voltage - dV (028)		2000	2300	2450	dV
Out 4 nominal voltage - dV (029)		2000	2300	2450	dV
Out 5 nominal voltage - dV (030)		2000	2300	2450	dV
Out 6 nominal voltage - dV (031)		2000	2300	2450	dV
Out 7 nominal voltage - dV (032)		2000	2300	2450	dV
Out 8 nominal voltage - dV (033)		2000	2300	2450	dV
Short circuit voltage threshold - V (034)	Minimum Voltage Threshold where module considers that outlet is in short circuit.	80	80	200	V
Short circuit hold time - ds (035)	Time Duration when a module tries to eliminate the short-circuit existing on outlet. If the system is still in short-circuit after this time, the output will be stopped.	1	600	6000	ds
Input source - % (036)	Defines the priority source 0 - Feeding from AC IN has priority (converter AC/AC - EPC mode) default value. 100 - Feeding from DC has priority (converter DC/AC - On Line mode)	0	0	100	%
Synchronisation tracking speed (037)	The speed at which the module tries to synchronize the AC Out with AC IN. The lowest value will have the fastest synchronization.	-2	0	2	
Max power - % (038)	Maximum Power that module can supply	30	150	150	%
Max current - % (039)	Maximum Current that module can supply.	30	150	150	%
Max overload duration - s (040)	Maximum Time Duration when module can run with overload	0	15	15	s



Parameter	Description	Min	Default	Max	Unit
AC in mode (041)	Allows to open the AC IN inlet relay 0 - normal running in EPC mode. 1 - AC IN inlet relay is open and so the system is insulated from the Mains. This parameter can be set to 1 only if repartition is on DC (parameter 036 should be 100)	0	0	1	
Booster 10x I in (042)	Allow to inhibit the Booster option which generates a current of 10 In for 20ms in case of short-circuit.	0	1	1	
Remote off disable AC in power (043)	This parameter change the attribution of the remote ON/OFF input. If parameter is 1, then, when system is in remote OFF position, output is not stopped and AC input is stopped instead.	0	0	1	
Reinjection allowed (044)	If this parameter is 1, the module is allowed to inject power in the grid with its AC input.	0	0	1	
External clock (045)	Records the "External Clock" mode configuration 0 - no protection in: phase drift is allowed. 1 - protection in: no phase drift allowed, stops the system after 1 minute. 2 - System stops immediately.	0	0	2	
Walk in mode - das (046)	The Walk-in mode allows the converter to come back progressively on the AC priority source after an outage. Friendly use on Genset	0	0	12	
Triangle mode (047)	Defines the protection type for working on Delta load. 0 - Default setting, and no delta load protection 1 - The mode is active. If one output phase stops, the other phases will also stop.	0	0	1	
Airco mode (048)	When this mode is activated, the overload capabilities are moved from default value to 330% overload in current and power for maximum 900 ms.	0	0	1	
Start without supervision (049)	When this mode is activated, the module is able to start without Inview S.	0	1	1	
P DC max - W (050)	This feature allow to limit or reduce the INRUSH DC current when the system work on battery. To limit the current this configuration line should limit the inrush DC current. To allow for the high capability this converter is build with extra capacitor running on 400VDC to provide the requested energy.	0	0	1	

## Appendix

Parameter	Description	Min	Default	Max	Unit
AC 1 stop power (051)	Stops the power of the corresponding AC group. The AC input of the modules of this AC group will then be used for synchronisation only, no power will be taken.	0	0	1	
AC 2 stop power (052)		0	0	1	
AC 3 stop power (053)		0	0	1	
AC 4 stop power (054)		0	0	1	
St module number (055)	NA	0	0	3	
St module redundancy (056)	NA	0	0	4	
Tus (057)	Mode TUS activation	0	0	1	
Tus modules number (058)	Number of TUS modules in the system (typically 2) -> number of tus seen by local supervision	0	0	24	
Tus sub sub system address (059)	address of the system on TUS bus -> address of local supervision which need to be different from other local supervisions	0	0	4	
Tus sub sub system output phase (060)	Output phase in TUS mode	0	0	11	
Tus sub system index (061)	System index in TUS mode (for example, if we have a A+B redundancy, this parameter is 1 for A systems, 2 for B systems)				
Number of tus sub sub system (062)	Number of systems connected on TUS bus	0	0	8	
Tus supply x supervision mode (063)	X TUS supply source	-	-	-	
Tus supply y supervision mode (064)	Y TUS supply source	-	-	-	
Tus sub sub system dc group (065)	DC group of the system in TUS mode	0	0	3	
V DC charger safe mode - cV (066)	DC voltage set point in SIERRA mode	5300	5400	5400	cV
P DC charger safe mode - W (067)	DC power setpoint in sierra mode (> 0 if battery discharge, <0 if battery charging)	0	-	2400	W
P AC peak shaving safe mode - W (068)	global peak-shaving (-1 if no peak-shaving)				
P AC max per phase safe mode - W (069)	Peak-shaving for each individual phase (-1 if no peak-shaving)				
Phase compensation (070)	Phase balancing	0	1	1	
Sierra mode (071)	Is module allowed to run in charger mode	0	1	1	
V DC low stop charger - cV (072)	Dc voltage under which charger is stopped	0	0	1	
Lvd mode (073)	If this mode is ON, module goes in low consumption mode 1 minute after it stops by Vdc LowStop	0	0	1	
Max V DC increment safe mode - cV (074)	Vdc set point rising speed when there is no supervision				

