



**CONNECT AND PROTECT**

# nVent ERIFLEX Flexbus Catalog and Technical Guide

2<sup>nd</sup> Edition

Easy-to-Install Flexible Power Connection Solution  
from 500 A to 6300 A



**ERIFLEX**

**HELIOS**  
POWER SOLUTIONS

[heliosps.com](http://heliosps.com)

Australia  
[sales-au@heliosps.com](mailto:sales-au@heliosps.com)  
+61 2 7200 9200

Asia  
[sales@heliosps.asia](mailto:sales@heliosps.asia)  
+65 6871 4140

New Zealand  
[sales-nz@heliosps.com](mailto:sales-nz@heliosps.com)  
+64 9 835 0700

Middle East  
[sales@heliosps.asia](mailto:sales@heliosps.asia)  
+971 4 4018484



Please contact your nVent ERIFLEX representative or contact us at [ERIFLEX.FleXbus@nVent.com](mailto:ERIFLEX.FleXbus@nVent.com).  
Our Calculation and Selection Tool is available online. Please contact your nVent ERIFLEX  
representative or register online.  
[go.nVent.com/FleXbusConfigurator](http://go.nVent.com/FleXbusConfigurator)



## WHY

At nVent, we believe that **safer systems ensure a more secure world**. We connect and protect our customers with **inventive electrical solutions**.

## HOW

nVent ERIFLEX delivers low-voltage power distribution solutions that reduce total installed cost and increase design flexibility by providing **a comprehensive range of innovative and reliable products** through global end-user application expertise and intimacy.

## WHAT

nVent ERIFLEX Flexbus is an **innovative and patented connection solution between two electrical equipment installations**, such as transformers, switchboards, generators or large uninterrupted power supplies (UPS). Due to its unique concept, nVent ERIFLEX Flexbus is an alternative power connection solution for up to 50% quicker installation and 20% reduction in total installed cost at a minimum.



[nVent.com/ERIFLEX](http://nVent.com/ERIFLEX) | 3

# Table of Contents

<b>General Information .....</b>	
<b>Introduction.....</b>	<b>6</b>
<b>System Index .....</b>	<b>7</b>
<b>Typical Applications .....</b>	<b>8</b>
<b>Features and Benefits.....</b>	<b>9</b>
<b>Technology Comparisons .....</b>	<b>10</b>
<b>Installation Overview .....</b>	<b>11</b>
<b>System Overview .....</b>	<b>12</b>
Advance Technology Insulation .....	13
Conductor .....	14
High Current Busbar Clamp (HCBC) and Plate .....	15
Supports.....	16
IP2x Boots .....	18
Palm Extender.....	19
IP55 and IP66 Conductor Entry .....	20
Fire Barrier System .....	21
Accessories .....	22
<b>Part Numbers.....</b>	<b>27</b>
Part Numbers and Packing Unit.....	27
<b>Quick Selection Guide .....</b>	<b>35</b>
Mandatory Product Selection.....	35
Optional Product Selection.....	35
<b>Standards and Certifications .....</b>	<b>36</b>
IEC Standards and Certifications.....	37
<b>Technical Data.....</b>	
<b>Conductors.....</b>	<b>38</b>
Technical Specifications.....	38
Dimensions and Weight.....	39
Selection .....	42
Ampacity.....	44
Conductor Arrangement.....	45
Cooling and Spacing Between Conductors .....	46
Recommendation for Transformer Connections.....	46
Skin Effect on Alternative Current (AC).....	47
Skin Effect and Frequency.....	48
Thermal Dissipation.....	49
Short-Circuit – Insulation Thermal Resistance .....	51
Flexibility and Bending Radius Comparison With Cable.....	52
Class II Insulation (Reinforced Insulation) .....	53
Altitude Effect.....	55
Low Smoke (LS) .....	55
Halogen-Free (HF).....	56
Flame Retardant (FR) .....	56
The European CPR Cable Regulations.....	57
EN 45545-2 Fire Testing to Railway Components.....	58
How to Achieve a Good Electrical Connection .....	59
Contact Kits.....	59
Connection and Distribution on Rigid Copper Bars.....	61
Connection to an Electrical Device .....	62
Voltage Drop.....	63
Harmonics .....	64
Precautions Against Magnetic Effects.....	67
EMC (Electromagnetic Compatibility) Recommendations .....	68
UV Resistance .....	69
Water Resistance .....	69
Vibration Resistance.....	70

# Table of Contents

Rodent Protection .....	70
Product Marking/Identification .....	71
<b>HCBC Clamp and Plate .....</b>	<b>72</b>
Technical Specifications .....	72
Mounting.....	74
Transformer Palm Mounting.....	76
<b>Optional Extender.....</b>	<b>77</b>
Technical Specifications .....	77
Type 1 – Mounting on Punched Busbars .....	79
<b>Support Kits - Edge and Flat .....</b>	<b>80</b>
Technical Specifications .....	80
Dimensions and Weight.....	81
Aluminum Perforated Profile: Dimensions and Weight .....	82
<b>Supports - Edge and Flat .....</b>	<b>83</b>
Mounting Possibilities .....	83
Possible Configurations.....	84
<b>Support Brackets.....</b>	<b>85</b>
Dimensions and Weight.....	85
<b>Supports .....</b>	<b>86</b>
Possible Configuration With 200% Neutral or PE+N Conductor.....	86
Grounding .....	87
Recommended Cable Tray Size .....	88
nVent CADDY – Fixing and Fastening Solutions for your FlexBus Installation.....	89
Phase Inversion, Neutral Rotation.....	90
Short-Circuit – Fixing and Securing.....	92
<b>Fire Barrier .....</b>	<b>94</b>
Technical Specifications .....	94
Mounting Information .....	95
Standard Reference .....	97
<b>Optional IP55 Conductor Entry and IP66 Upgrade Kit .....</b>	<b>98</b>
Technical Specifications .....	98
<b>Optional IP2x Boots.....</b>	<b>99</b>
Technical Specifications .....	99
<b>Disposable Stripper Cutter .....</b>	<b>100</b>
Technical Specifications .....	100
<b>Scissors and Shears.....</b>	<b>100</b>
Technical Specifications.....	100
<b>FlexBus Aluminum Rail Cutter and Insert Crimper .....</b>	<b>101</b>
Technical Specifications.....	101
<b>Identification Kit.....</b>	<b>102</b>
Technical Specifications .....	102
<b>Other Data .....</b>	<b>.....</b>
<b>System Life Expectancy .....</b>	<b>103</b>
<b>FlexBus Conductor Insulation Repair.....</b>	<b>103</b>
<b>Periodic Check Testing of an Installation.....</b>	<b>104</b>
<b>nVent ERIFLEX FlexBus Made-to-Order Solutions .....</b>	<b>105</b>
<b>FlexBus Services.....</b>	<b>106</b>
<b>Environment .....</b>	<b>107</b>
<b>3D Design of a FlexBus Pathway .....</b>	<b>108</b>
<b>Dedicated nVent ERIFLEX Calculation and Selection Tool Available .....</b>	<b>109</b>
<b>Patents.....</b>	<b>110</b>
<b>Website .....</b>	<b>110</b>
<b>Application Pictures .....</b>	<b>111</b>
Additional nVent ERIFLEX Literature .....	114
Catalogs.....	114
Technical Guides .....	114

# Introduction

The nVent ERIFLEX FleXbus System is an innovative and patented connection solution between two electrical equipment installations, such as transformers, switchboards, generators or large uninterrupted power supplies (UPS).

This unique concept brings an alternative solution to the market, providing faster installation and reducing total install cost.

FleXbus maintains a high level of reliability and creates an easy and customizable connection on-site without additional design study, specific specialized workforce or expensive tools.

FleXbus incorporates nVent ERIFLEX Advanced Technology that provides unique features to create a conductor that is low smoke, halogen-free, flame retardant (LSHFRR) and high-temperature resistant.

FleXbus is a unique and complete low-voltage power connection system designed for multiple applications, including:

- Connections from transformers to switchgears
- Interconnection between transformers
- Connections from or to generators
- Switchgear interconnections
- Machine connections



Please contact your nVent ERIFLEX representative or contact us at [ERIFLEX.FleXbus@nVent.com](mailto:ERIFLEX.FleXbus@nVent.com). Our Calculation and Selection Tool is available online. Please contact your nVent ERIFLEX representative or register online. [go.nVent.com/FleXbusConfigurator](https://go.nVent.com/FleXbusConfigurator)

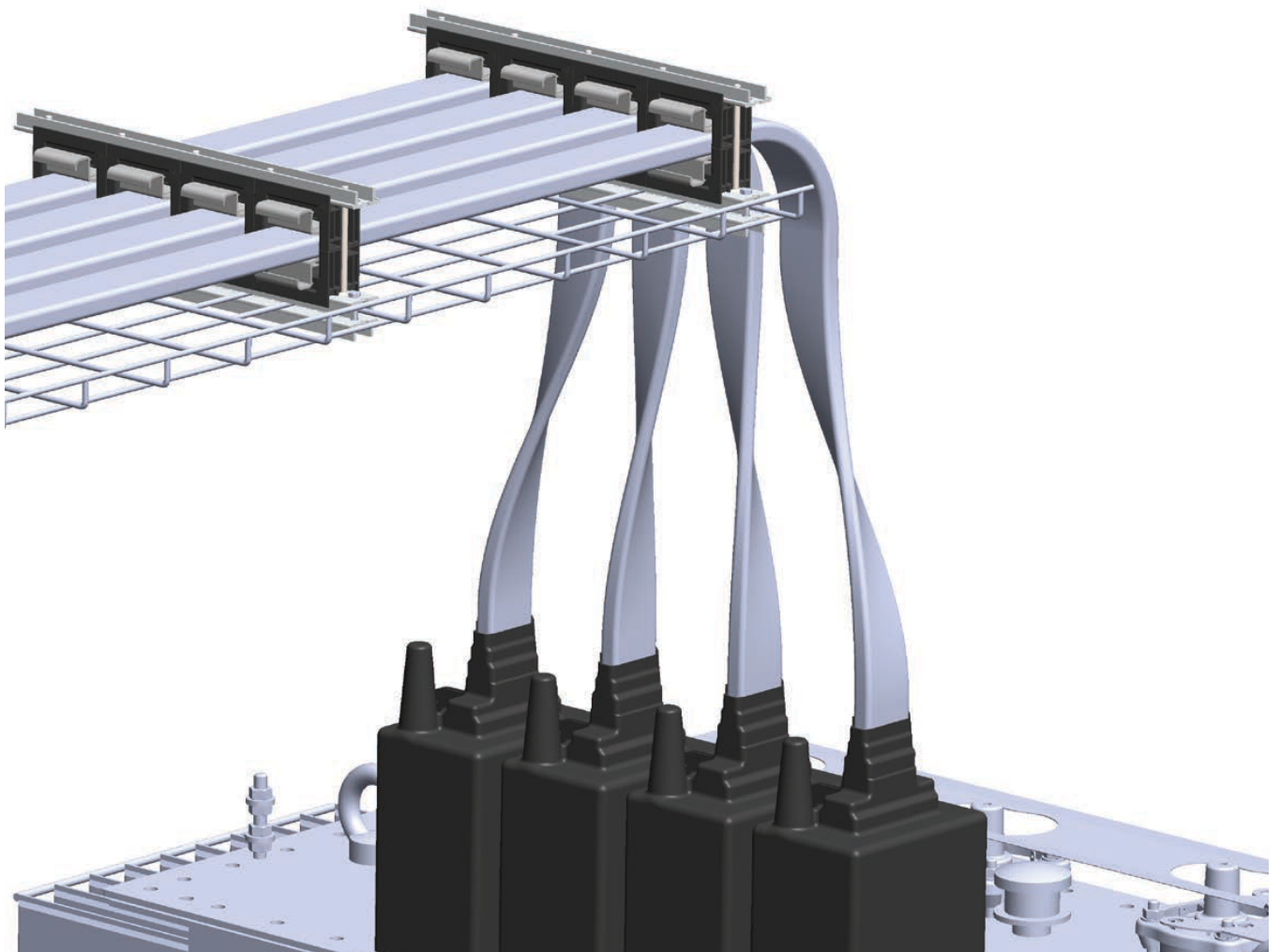

# System Index

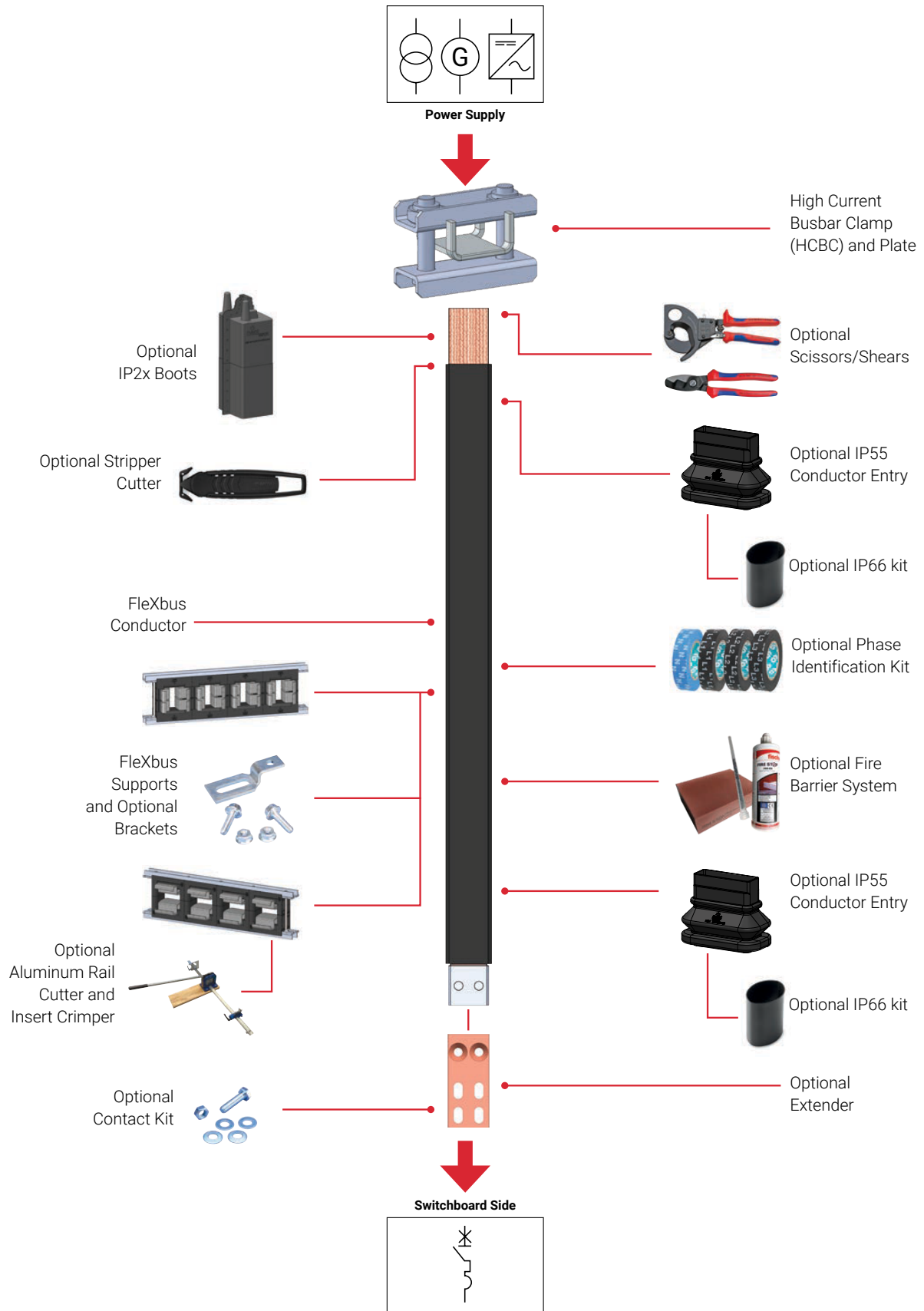

General Information

Technical Data

Other Data

# Typical Applications

General Information

Technical Data

Other Data

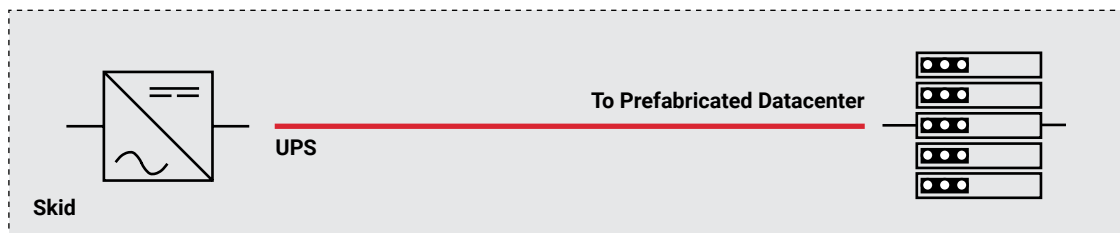
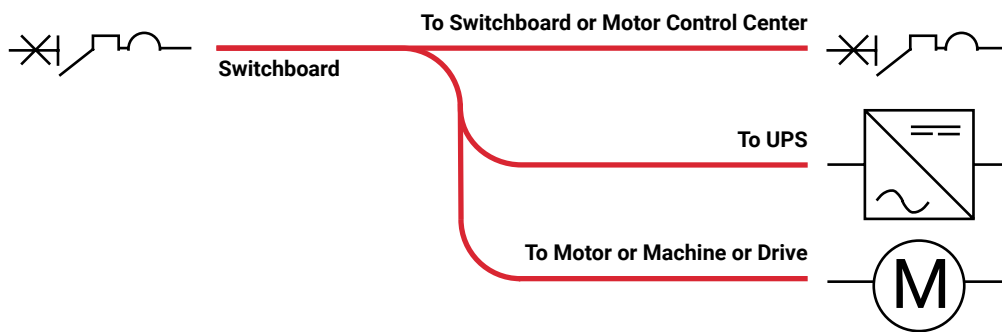
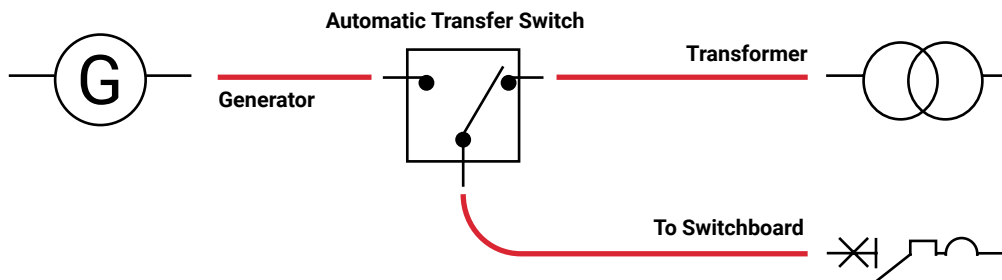
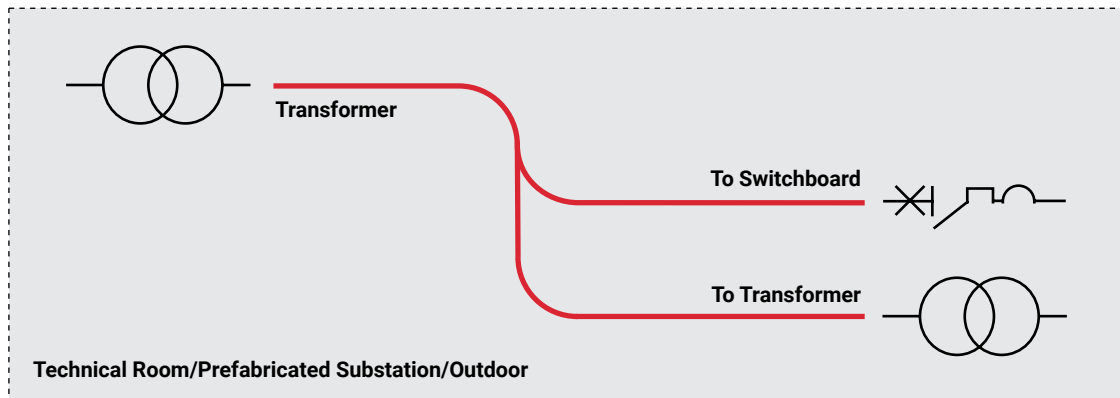



# Features and Benefits



## OPERATING ADVANTAGE

- Versatile, customizable, user friendly, no specific tool required. Attractive for short distances, up to 25 meters.
- No specialized labor force necessary with a ready-to-use solution.
- Very flexible conductor with no bending radius to follow.
- Achieve virtually any layout and overcome any imperfections that may be found on-site.
- No cable tray necessary to support Flexbus Conductors.



## SPACE AND WEIGHT

- Only one conductor per phase from 400 kVA (560 A) to 1600 kVA (2250 A) and two conductors per phase for 2000 kVA (2800 A) to 3150 kVA (4435 A) when cable solution requires multiple conductors per phase. 3 Flexbus conductors per phase for 5000 & 6300 A
- No need for specific engineering/study or strict installation measurement.
- Total install cost reduction of 20% minimum.



## TIME SAVING

- Up to 50% quicker to install than busduct or wireway/cable tray with multiple cables and lugs.



## RELIABILITY AND SAFETY



- IEC worldwide tested and certified.
- Low smoke, halogen-free, flame retardant and high-temperature resistant.

# Technology Comparisons

General Information

Technical Data

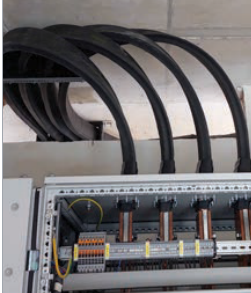
Other Data

	Flexbus	Cables and Lugs	Busduct
			
Ready to Use	Yes	No	Yes
Field Customization	Yes	Yes	No
Delivery Time	Short	Short	Long
Bending Radius/System Rigidity	Easy	Difficult	N/A
Pre-Installation Measurement and Study	No	No	Yes
Qualified Workforce	No	Yes	Yes
Minimum People for Installation	1	2	2
Typical Current Usage	500 to 6300 A	< 2000 A	> 2000 A
Installation Time	< 1 Day	> 1 Day	> 1 Day
Number of Conductors Per Phase	1 or 2 or 3	Multiple	1 or 2
Weight	Light	Medium	Heavy
Tools Required	None	Multiple	Low
Installation Preparation Time	None	Low	High
Human Error Risk	Low	High	Medium
Total Installation Cost	Low	Medium	High

# Installation Overview

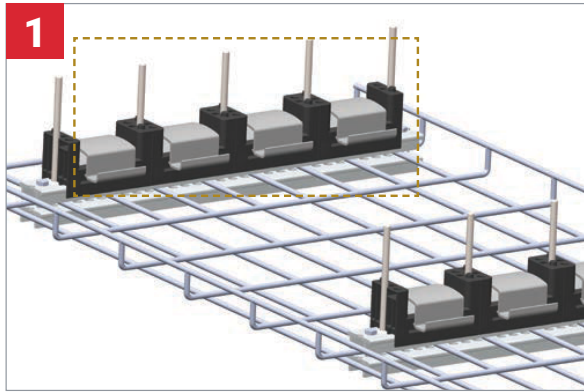

**1** **Install** supports directly to the wall, ceiling or on any type of cable tray (wire basket/perforated/cable ladder). Use multiple possible mounting configurations to meet your installation configuration (flat/on-edge).

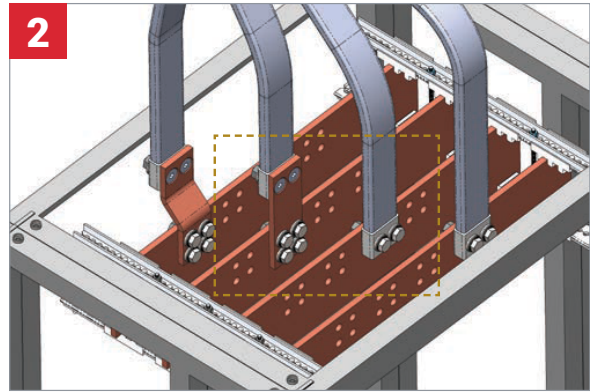

**2** **Connect** the ready-to-use Flexbus Conductor to the switchboard. This conductor has pre-punched holes and can be connected directly to the busbar or to the circuit breaker palm. Optional extenders are available.

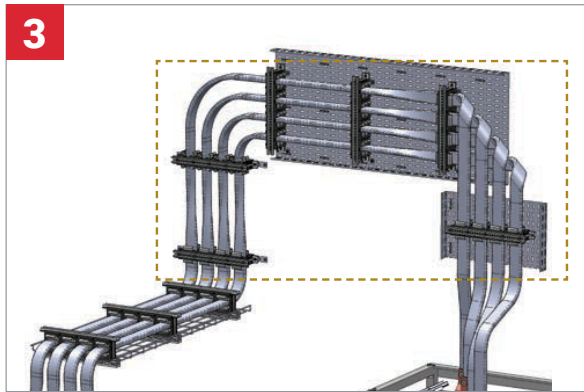

**3** **Install** conductors into the supports and mount the top part of the supports. Leave conductors' excess length at the top of the transformer/power supply.

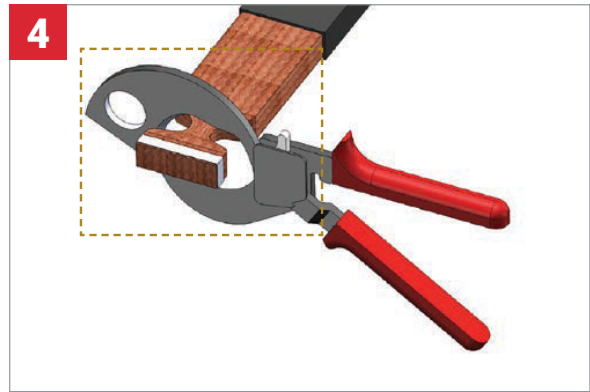

**4** **Strip** Flexbus Conductor insulation. **Cut** Flexbus Conductor excess length with Flexbus scissors or shears.

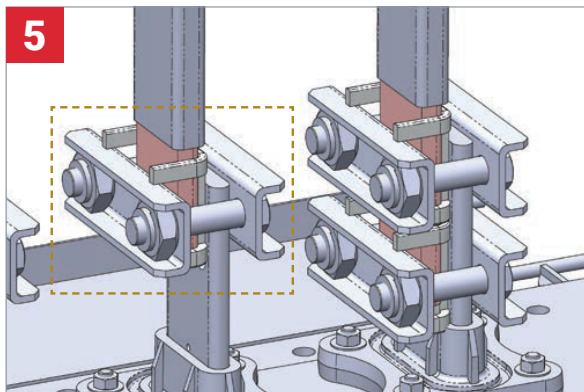

**5** **Connect** Flexbus Conductor with High Current Busbar Clamp (HCBC) and Plate.

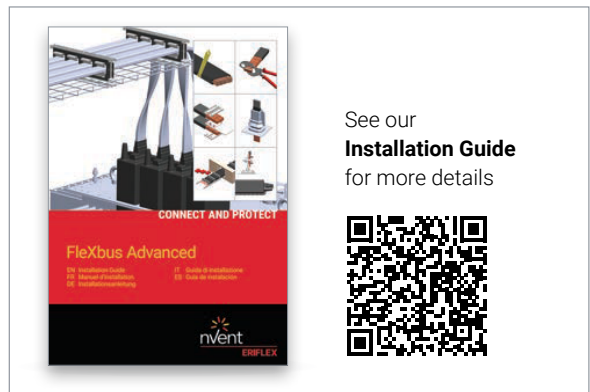

See our **Installation Guide** for more details



# System Overview

General Information

Technical Data

Other Data



**Advanced Technology**  
[Page 13](#)



**Supports**  
[Pages 16-17](#)



**Conductor**  
[Page 14](#)

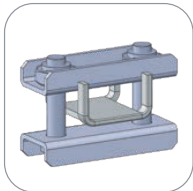

**High Current  
Busbar Clamp  
(HCBC) and Plate**  
[Page 15](#)



**IP2x Boots**  
[Page 18](#)

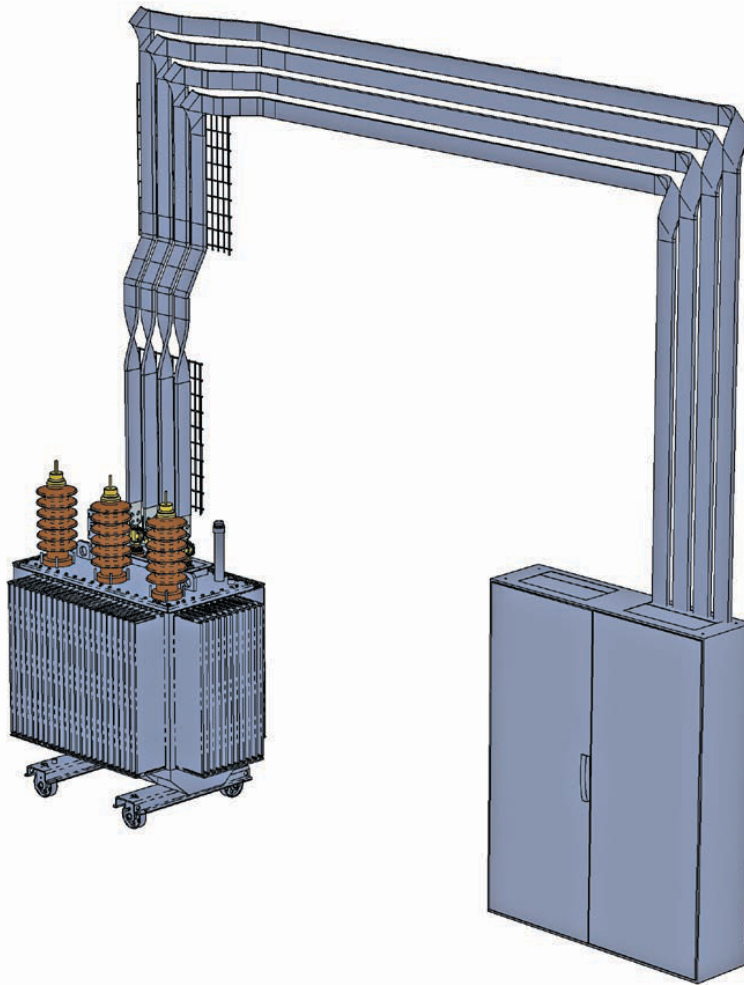

**IP55 and IP66  
Conductor Entry**  
[Page 20](#)



**Fire Barrier System**  
[Page 21](#)

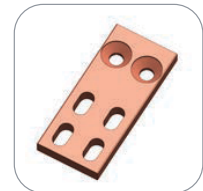

**Palm Extender**  
[Page 19](#)



**Accessories**  
[Page 22-24](#)

# System Overview

## Advance Technology Insulation



### NVENT ERIFLEX ADVANCED TECHNOLOGY

The volume of power conductors and electrical devices drastically increases across industrial, commercial and residential environments. So, too, does the demand for manufacturers to choose proper electrical protection for both equipment and people. Fires that involve dangerous plastic can produce toxic fumes, injuring people and damaging equipment.



[Learn more about nVent ERIFLEX Advanced Technology](#)



Advanced Technology is compliant to UL 94 V-0 and/or IEC 60695-2-11 (Glow Wire Test 960°C). The **flame-retardant** portion of the test illustrates the self-extinguishing feature, reducing the risk of the spread of fire and potential damage to your electrical installation. It also reduces the damage on electrical installations. Advanced Technology also has a Limiting Oxygen Index (LOI) at 30%.

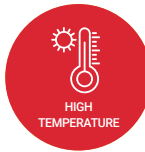

Thanks to its unique features, Advanced Technology used with Flexbus Conductor is also a Class II conductor with a **high-temperature resistance** up to 115°C.



The **low-smoke** feature measures the quantity of smoke in case of an emergency such as combustion. This feature helps to determine the smoke density generated during a fire. Flexbus Conductor comply with UL 2885 and IEC 60754-2, meaning that the light transmittance improved the visibility.

**Advanced Technology** means greater safety for individuals, less damage for your electrical equipment and less environmental impact.



As further chemical research demonstrates halogen materials' highly corrosive and toxic nature, the demand for halogen-free solutions has risen to protect both electrical equipment and safety of people.

**Advanced Technology meets halogen-free requirements** according to IEC 60754-1 and/or UL 2885 standards. In the case of a fire, Advanced Technology does not induce corrosive gases and instead produces mainly steam with a low level of carbon monoxide.

Advanced Technology contains halogen-free materials and offers better protection for people's safety and your electrical installation by reducing corrosion and toxic smoke generation.

General Information

Technical Data

Other Data

# System Overview

## Conductor

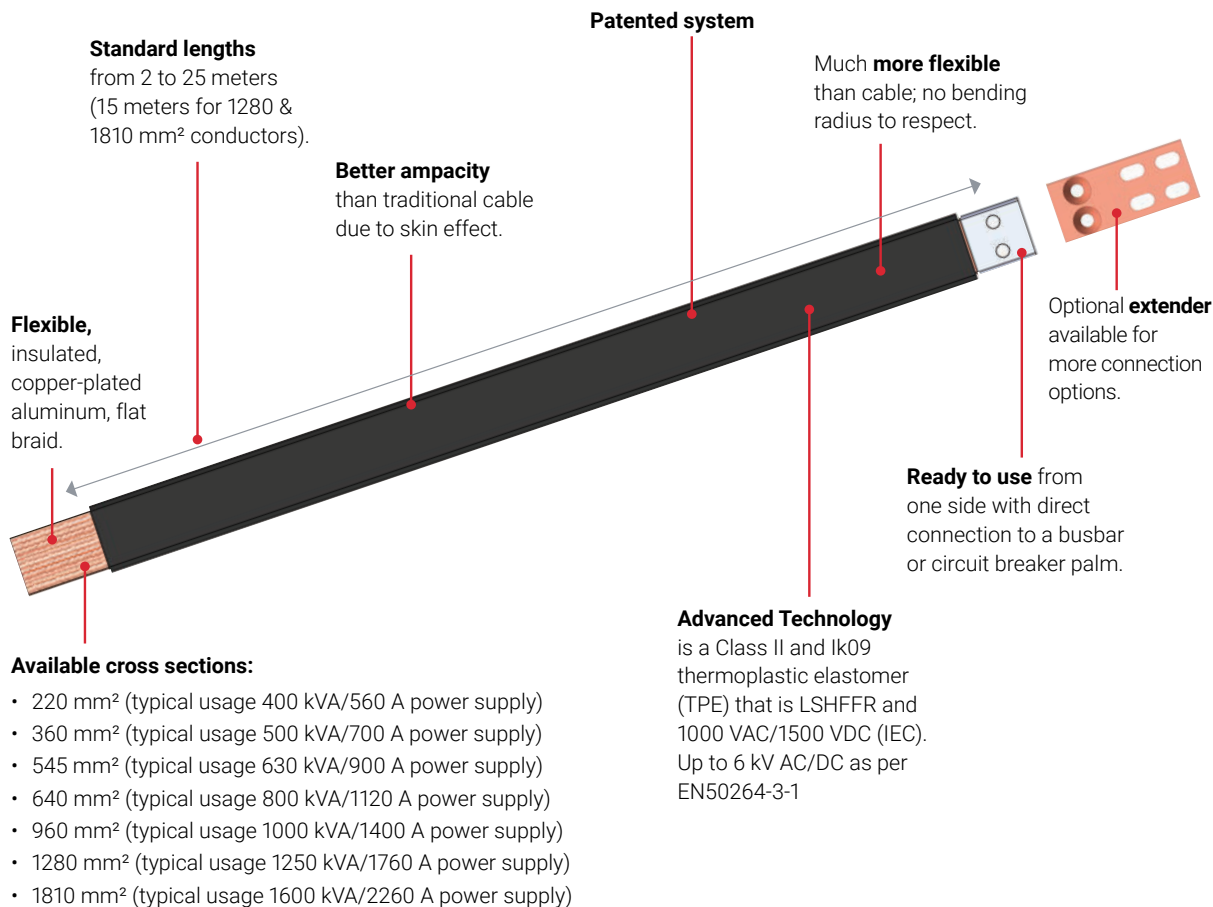
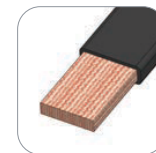

### TYPICAL ALUMINUM/COPPER CABLE AND BUSDUCT USAGE COMPARISON WITH FLEXBUS SYSTEM

HV/LV Transformer 410 V at Secondary	Current LV - I <sub>n</sub> (A)	Typical Usage Copper Cable/Phase	Typical Usage Aluminum Cable/Phase	Typical Power Busduct Usage	Flexbus Conductor/Phase
400 kVA	560	1x240 mm <sup>2</sup> ●	2x240 mm <sup>2</sup> ●●		1x220 mm <sup>2</sup> █
500 kVA	704	2x185 mm <sup>2</sup> ●●	3x240 mm <sup>2</sup> ●●●		1x360 mm <sup>2</sup> █
630 kVA	900	2x240 mm <sup>2</sup> ●●	4x240 mm <sup>2</sup> ●●●●		1x545 mm <sup>2</sup> █
800 kVA	1120	3x185 mm <sup>2</sup> ●●●	4x240 mm <sup>2</sup> ●●●●		1x640 mm <sup>2</sup> █
1000 kVA	1400	4x185 mm <sup>2</sup> ●●●●	4x300 mm <sup>2</sup> ●●●●		1x960 mm <sup>2</sup> █
1250 kVA	1760	4x240 mm <sup>2</sup> ●●●●	4x400 mm <sup>2</sup> ●●●●	Busduct	1x1280 mm <sup>2</sup> █
1600 kVA	2253	5x240 mm <sup>2</sup> ●●●●●		Busduct	1x1810 mm <sup>2</sup> █
2000 kVA	2816	6x240 mm <sup>2</sup> ●●●●●●		Busduct	2x960 mm <sup>2</sup> █
2500 kVA	3520	8x240 mm <sup>2</sup> ●●●●●●●●		Busduct	2x1280 mm <sup>2</sup> █
3150 kVA	4435			Busduct	2x1810 mm <sup>2</sup> █
3350 kVA	4717			Busduct	3x960 mm <sup>2</sup> █
3600 kVA	5069			Busduct	3x1280 mm <sup>2</sup> █
4500 kVA	6336			Busduct	3x1810 mm <sup>2</sup> █

# System Overview

## High Current Busbar Clamp (HCBC) and Plate

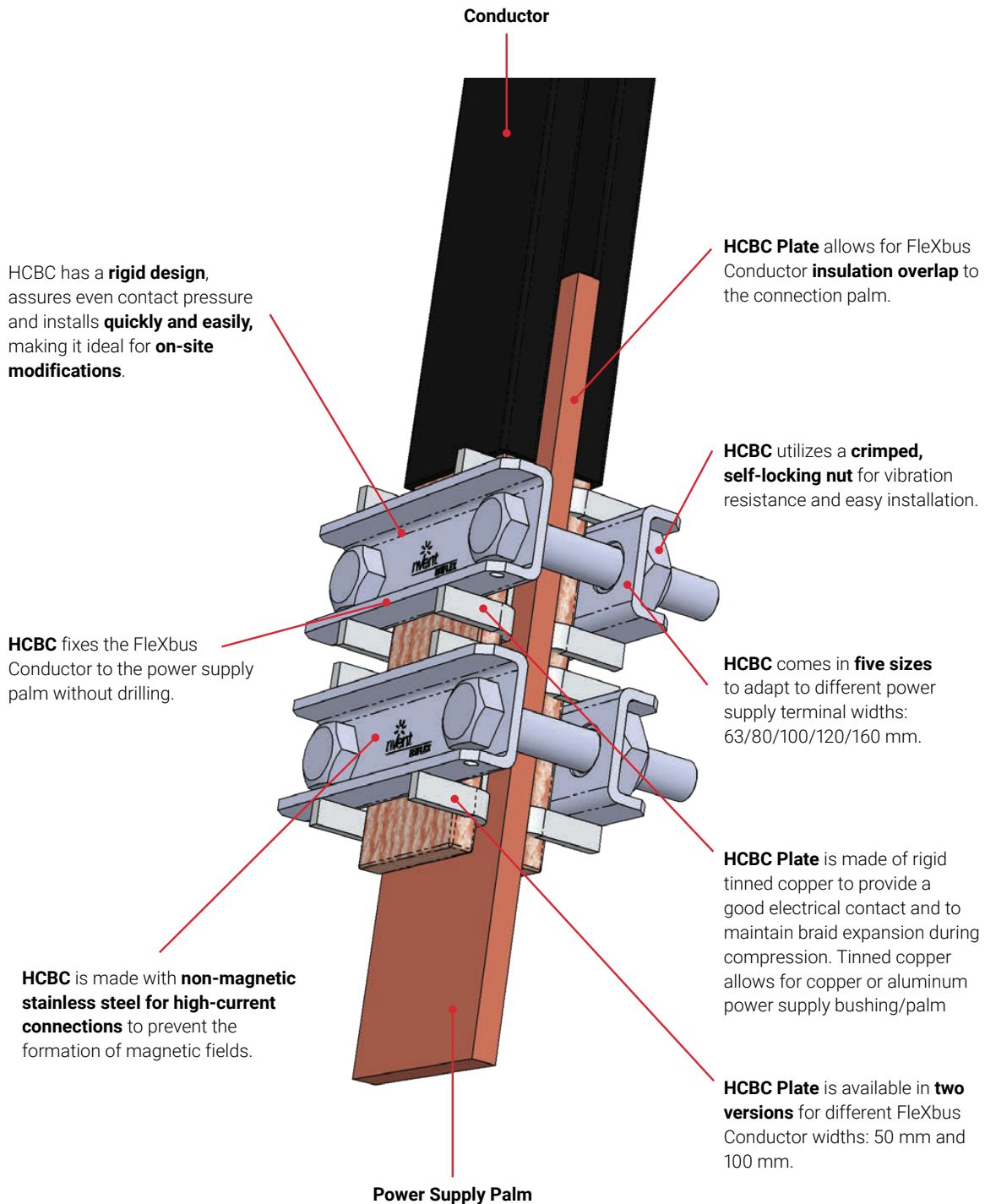
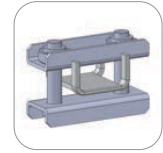

General Information

Technical Data

Other Data

# System Overview

## Supports

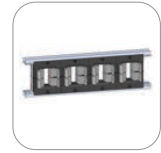

### SUPPORT EDGE

**Punched-hole aluminum profile** to fix the support directly on the wall, on the ceiling or on cable tray (wire/perforated/ladder cable tray). Optional brackets are available.

**Adjustable clip** to adapt the support with different conductor thicknesses (open/closed position).

Made with glass fiber-reinforced polyamide, **halogen-free**, RoHS compliant, working temperature of  $-40^{\circ}\text{C}$  to  $130^{\circ}\text{C}$ , flammability rated to UL 94 V-0 and IEC 60695-2-11 (Glow Wire Test  $960^{\circ}\text{C}$ ) and low smoke as per ISO 5659-2.

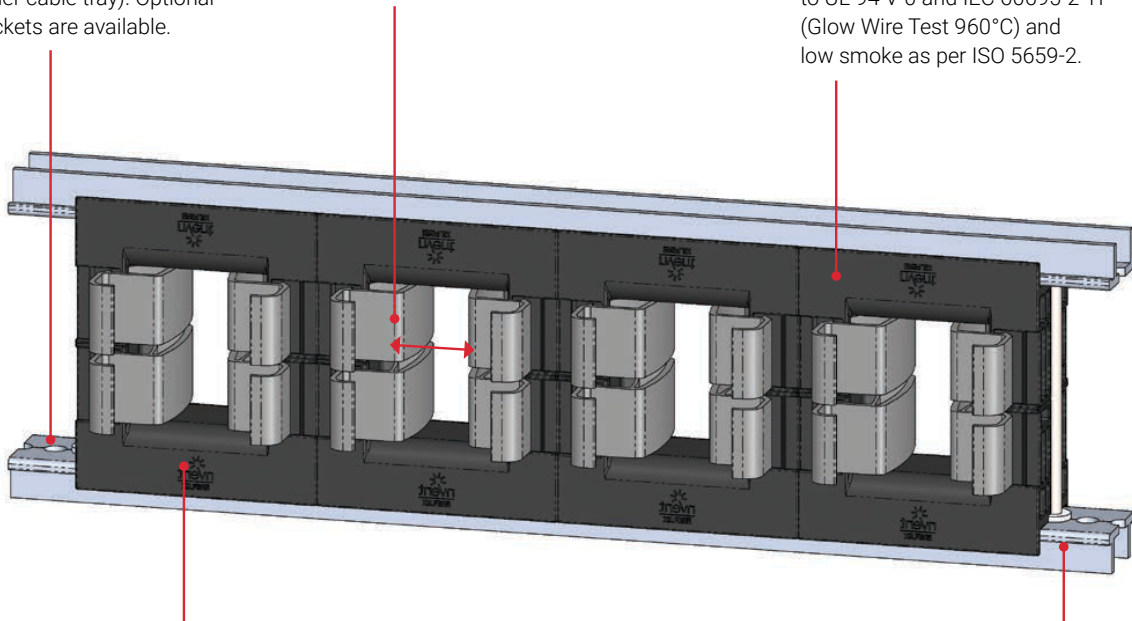

**FleXbus support kits** are easy to mount, with multiple configurations possible.

- 3P/3P+N/3P+N+PE
- One or two conductors per phase
- Side by side or on top
- Adjustable distance between each conductor (12.5 mm pitch)

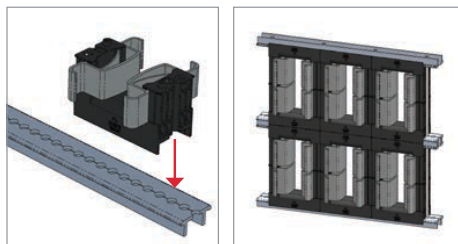

**Strong mechanical resistance** and short-circuit tested as per IEC 61914 up to 67 kA rms – 147 kA Peak.

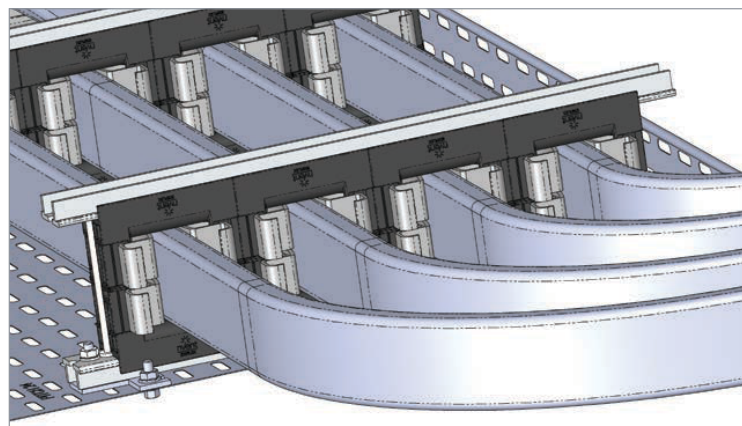
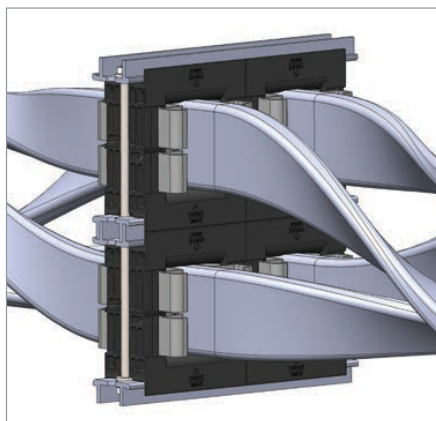



# System Overview

## Supports



### SUPPORT FLAT

Made with glass fiber-reinforced polyamide, **halogen-free**, RoHS compliant, working temperature of  $-40^{\circ}\text{C}$  to  $130^{\circ}\text{C}$ , flammability rated to UL 94 V-0 and IEC 60695-2-11 (Glow Wire Test  $960^{\circ}\text{C}$ ) and low smoke as per ISO 5659-2.

**Strong mechanical resistance** and short-circuit tested as per IEC 61914 up to 67 kA rms – 147 kA Peak.

**Punched-hole aluminum profile** to fix the support directly on the wall, on the ceiling or on cable tray (wire/perforated/ladder cable tray). Optional brackets are available.

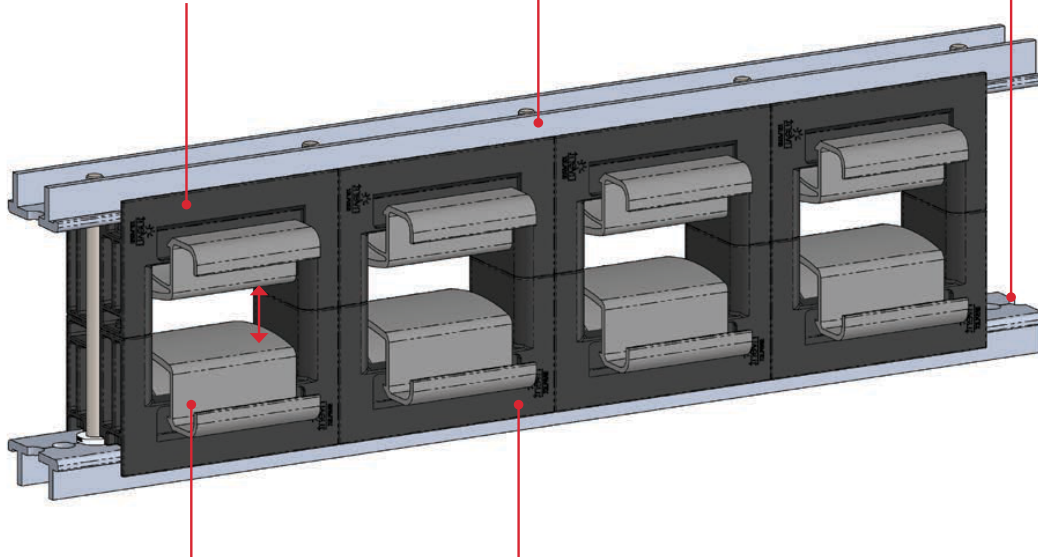

**Adjustable clip** to adapt the support with different conductor thicknesses (open/closed position).

**FleXbus support kits** are easy to mount, with multiple configurations possible.

- 3P/3P+N/3P+N+PE
- One or two conductors per phase
- Side by side or on top
- Adjustable distance between each conductor (12.5 mm pitch)

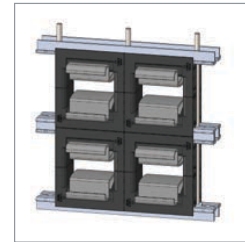
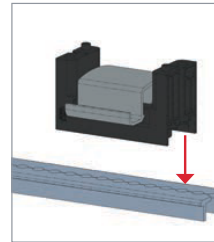

### SUPPORT BRACKETS

Bracket CABS – E



Bracket CABS – M



Bracket CABS – T

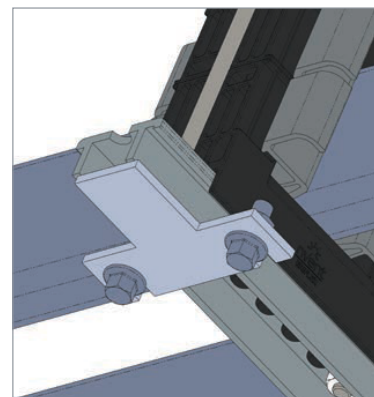
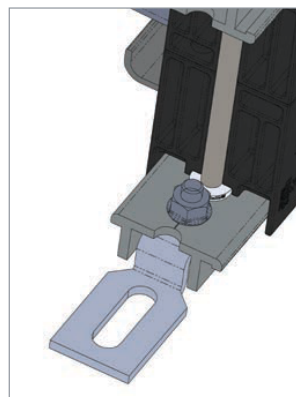

# System Overview

## IP2x Boots

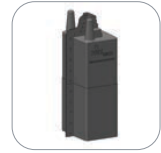

**IP2x Boots** for use when a transformer or generator is not equipped with its own cover. Provides an IP2x protection (finger safe) to the low-voltage connecting point. Provides protection against accidental contact with live parts greater than 12 mm.

**IP2x Boots can be adapted to any conductor cross section** by cutting the top material with a traditional cutter.

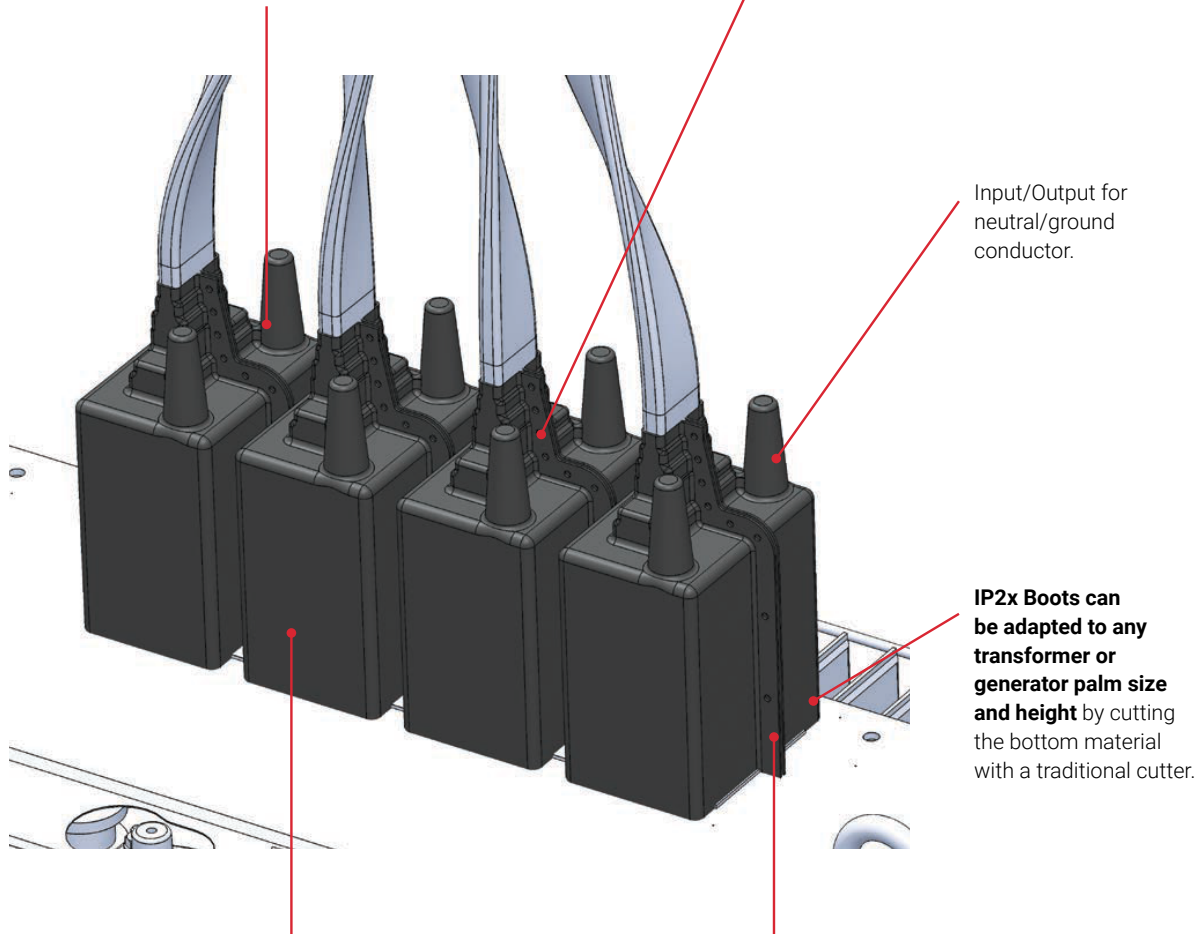

Input/Output for neutral/ground conductor.

**IP2x Boots can be adapted to any transformer or generator palm size and height** by cutting the bottom material with a traditional cutter.

Made with high resistant and flexible PVC, **flame retardant and 140°C temperature resistant.**

**Easy and quick to install** with closing clips, after conductor installation.

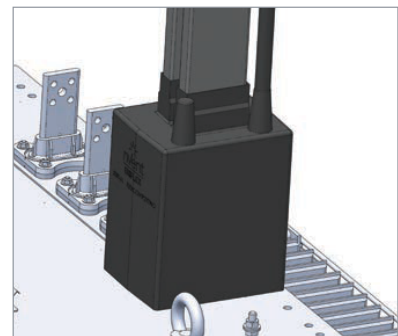
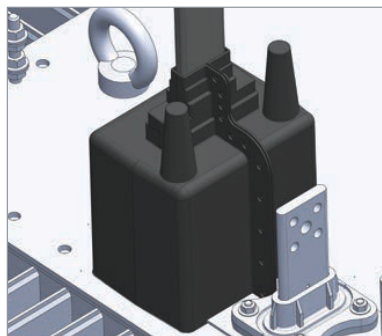
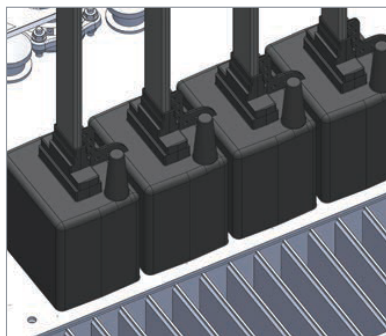

# System Overview

## Palm Extender

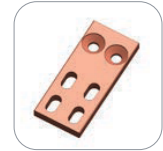

**FleXbus Conductor is ready to use** from one side with direct connection on busbar or circuit breaker palm. However, optional **extenders** are available for more connection possibilities.

### Extender Cross Sections:

- 50x10 mm for FleXbus Conductor 220, 360, 545 and 640 mm<sup>2</sup>
- 100x10 mm for FleXbus Conductor 960, 1280 and 1810 mm<sup>2</sup>

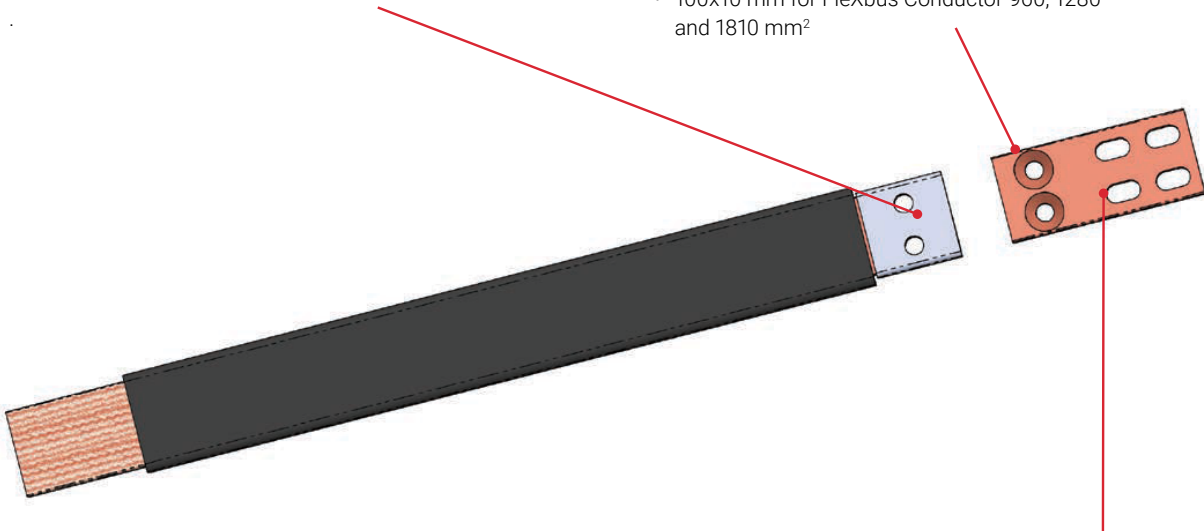

**Palm Extender** connects the busbar to the switchboard, air circuit breaker or load break switch.

Type 1	Type 2	Type 3
Predrilled	Plain	Plain
Flat	Flat	Bended



# System Overview

## IP55 and IP66 Conductor Entry



Made with soft PVC to **follow any conductor bending radius.**

The sealing around the conductor is made with a **self-fusing tape** with a strong adhesive.

**IP55 Conductor entry** can be used for switchboard and/or power supply cover to upgrade installation to IP55 level (**dust and water proof**)

IP55 Conductor entry **can be adapted to any FleXbus Conductor cross section** by cutting the top material with a traditional cutting tool.

Optional Heat shrink Tubing to upgrade from IP55 to IP66

Made with highly resistant and flexible PVC, **Flame retardant, and 140°C temperature resistant.**

High acid and basic resistance Good resistance to solvent and hydrocarbon splashes Good UV resistance

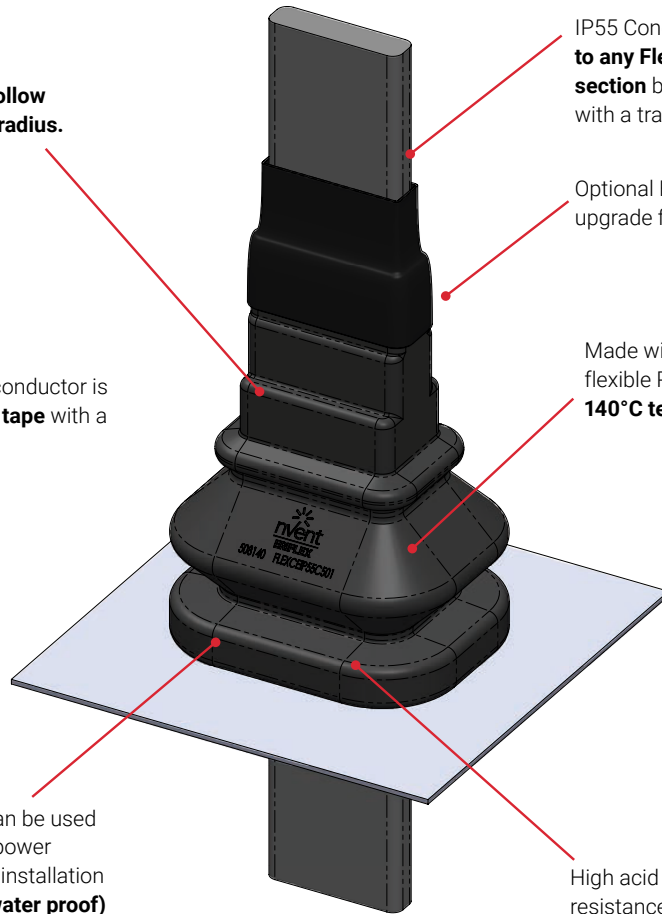

Available in two variations for one conductor or two conductors per phase

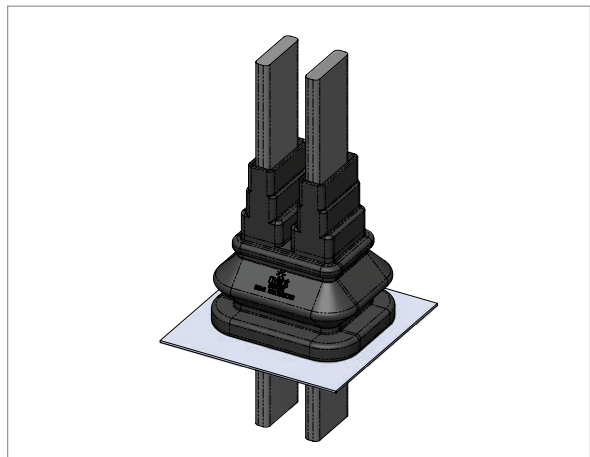
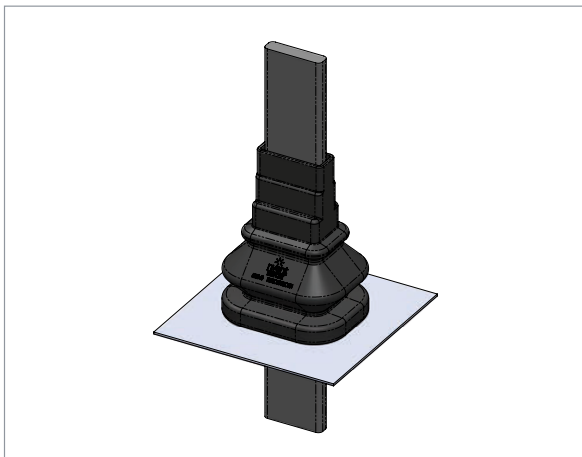

# System Overview

## Fire Barrier System



**Fire Barrier Blocks (FBBs)** are highly elastic moldable blocks.

**Foam Barrier System (FBS)** is a two-component, polyurethane, expanding, sound-, smoke- and fire-stopping seal for hard-to-reach locations, which expands up to five times its volume.

**FleXbus Insulating Bandage (FIB):** Intumescent wrap on the basis of butyl rubber with intumescent fire protection additives and glass fabric reinforcement. To be used around FleXbus Conductor if the thickness of the penetration seal is < to 200 mm.



**Easy access** for difficult-to-reach openings. Various applications with only two products:

- Aging resistant
- Smoke resistant
- Damp resistant
- Re-enterable and repairable
- Excellent adhesion
- No backing material required
- F-rating/E-rating up to two hours
- T-rating/L-rating up to two hours

**Fire Barrier:** Quick and easy to install. Up to two-hour fire resistance (EI 120), with ETA (CE Marked) and EN 1366-3 tested or UL-Certified ASTM E-814 (UL 1479).

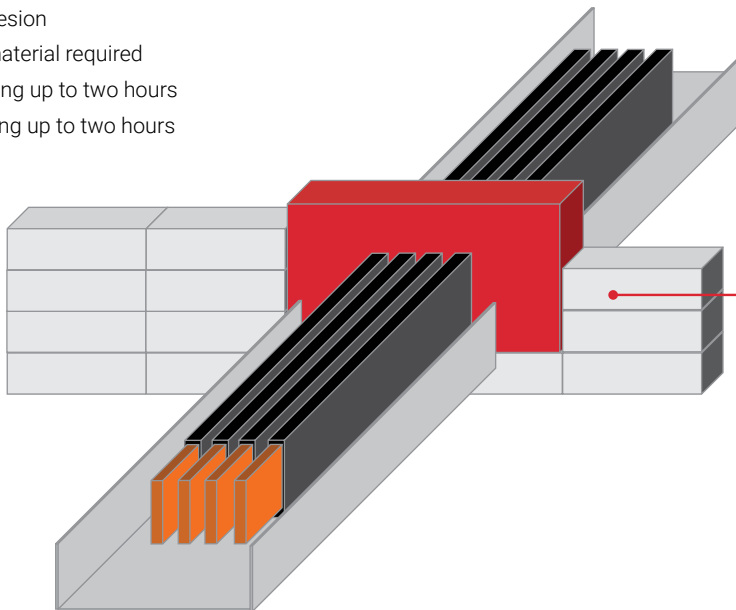

**Building material:**

- Concrete (wall and floors)
- Masonry
- Flexible wall

General Information

Technical Data

Other Data

# System Overview

## Accessories

### SCISSORS AND SHEARS

General Information

Technical Data

Other Data

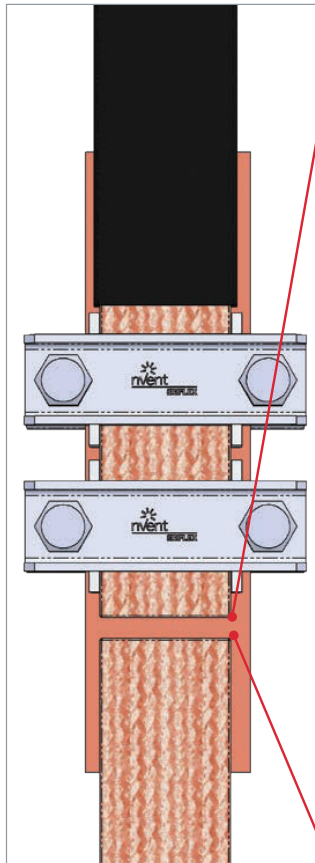

Scissors **to cut the excess conductor length** at the power supply palm.

Precision-ground, hardened blades. **Clean and smooth cut** without crushing or deforming the conductor.

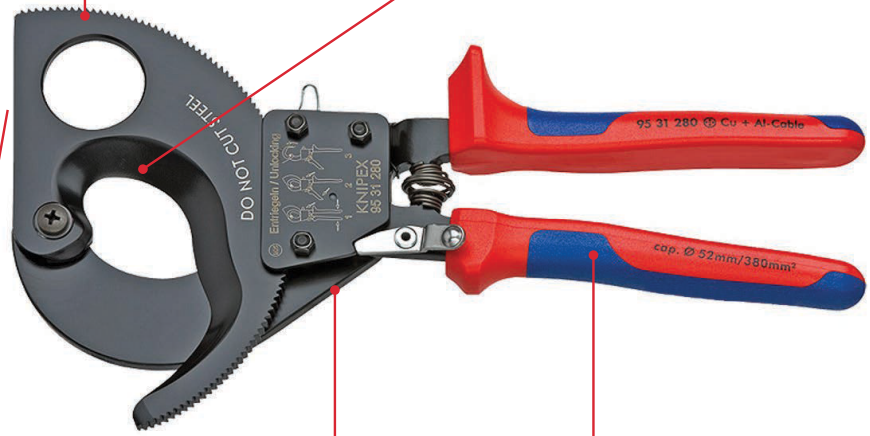

Simple handling as a result of low weight and compact design; **can be used in confined areas**. Guard prevents operators' fingers from being pinched. High-grade special tool steel, forged and oil-hardened.

One-hand operation using ratchet principle. **Low amount of hand force required** due to very high transmission ratio. Two-stage ratchet drive for easy cutting.

Precision-ground, hardened blades. **Clean and smooth cut** without crushing or deforming the conductor.



Less effort required due to favorable lever ratio and optimized cutting-edge geometry.

Guard prevents operators' fingers from being pinched.

Adjustable bolted joint, self-retaining screw.

High-grade special tool steel, forged and oil-hardened.

# System Overview

## Accessories

### FLEXBUS ALUMINUM RAIL CUTTER AND INSERT CRIMPER

**Cuts FleXbus Aluminum Perforated Profile** without burrs or deformation and chip-free

**Safe** usage and conditions

**Crimps the threaded rods insert** on the aluminum rail (from top or bottom)

Includes ruler, guide, and end stops

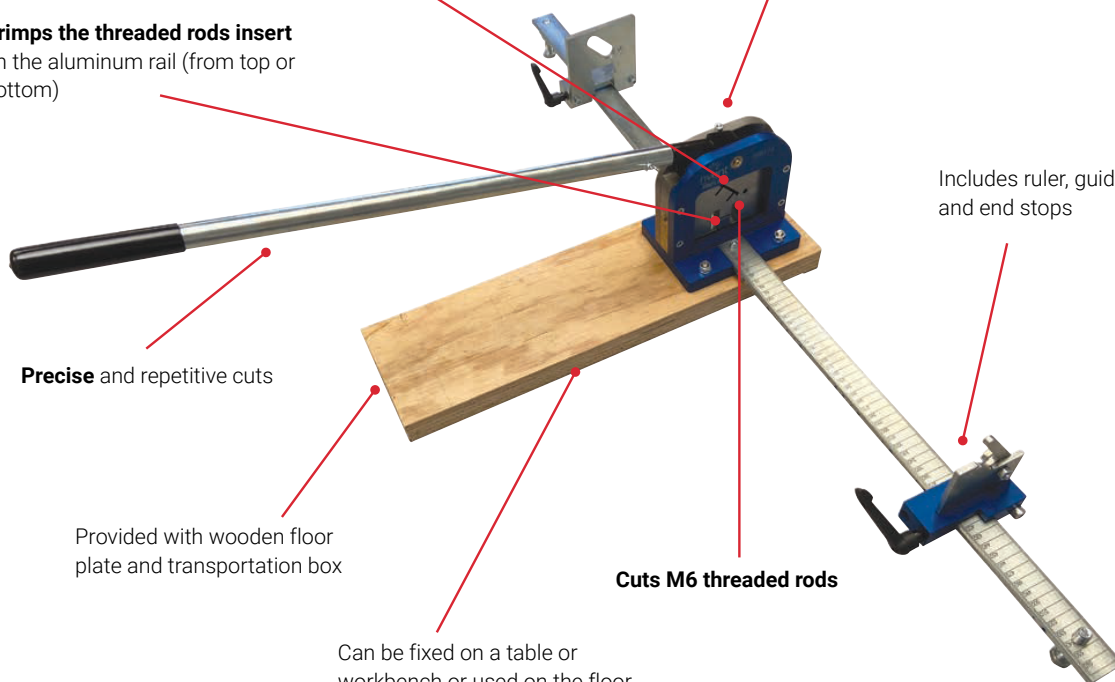

**Precise** and repetitive cuts

Provided with wooden floor plate and transportation box

**Cuts M6 threaded rods**

Can be fixed on a table or workbench or used on the floor with the supplied wooden plate

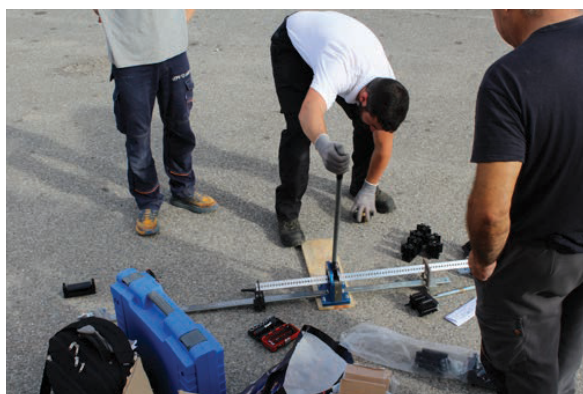

General Information

Technical Data

Other Data

# System Overview

## Accessories

### STRIPPER CUTTER

**Double-blade**, high-quality carbon steel and advanced plastic polymers.

Recessed blade reduces cut injuries and allows **stripping of the Flexbus Conductor** insulation without damaging the conductive multiwire braid.



**Protection of the user:** Risk of injury is eliminated; contact of fingers with blades is impossible.

### PHASE IDENTIFICATION KIT

- Rubber tape N
- Rubber tape L1
- Rubber tape L2
- Rubber tape L3
- Flexbus sticker



- Flame retardant
- Self-extinguishing
- Conformable
- Abrasion resistant
- UV resistant
- Non-corrosive adhesive

System connected with **Flexbus Advanced**



### CONTACT KIT

Available in M6/M8/M10 and M12 in different lengths.

Kit includes 100 bolts, 100 nuts, 200 flat washers and 200 contact washers.

For **optimal** electrical connections.

**Material:** Steel  
**Finish:** Electrogalvanized  
**Quality Class:** 8.8  
**Coating Class:** Zn 8C

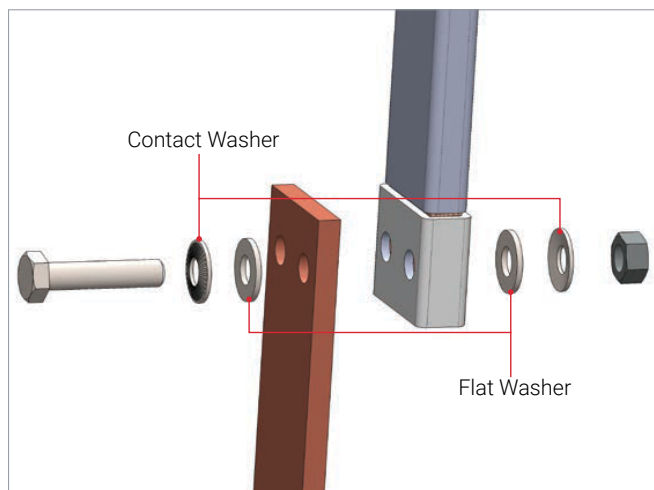



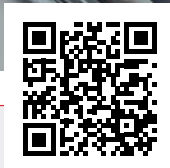
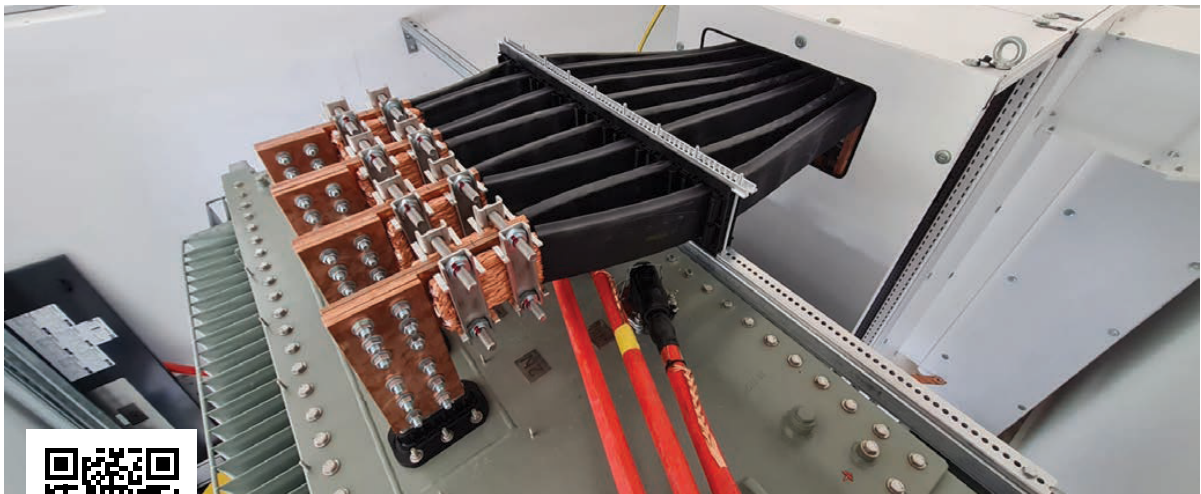
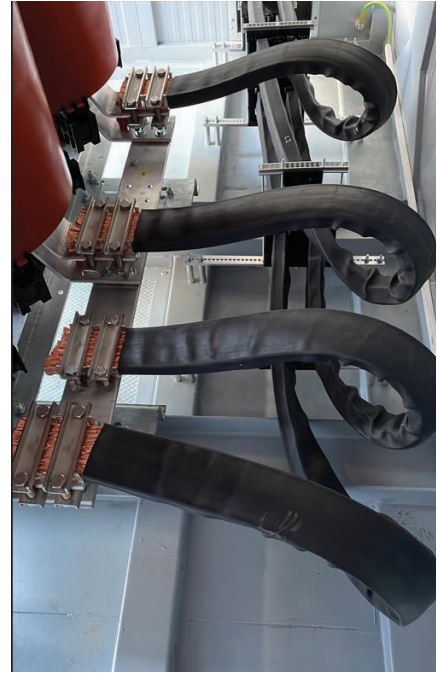

Our Calculation and Selection Tool is available online. Please contact your nVent ERIFLEX representative or register online. [go.nVent.com/FleXbusConfigurator](https://go.nVent.com/FleXbusConfigurator)

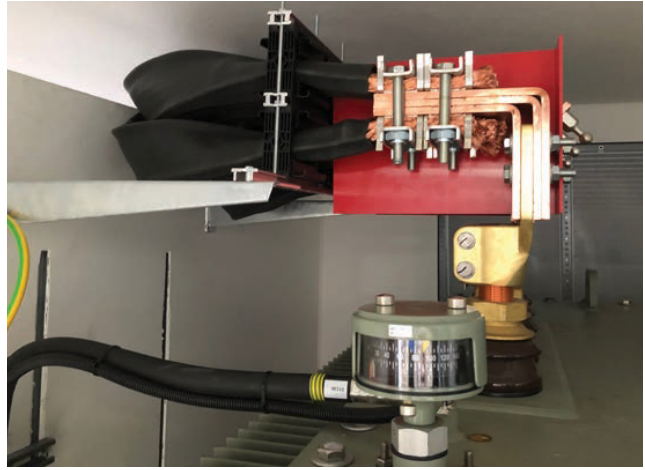
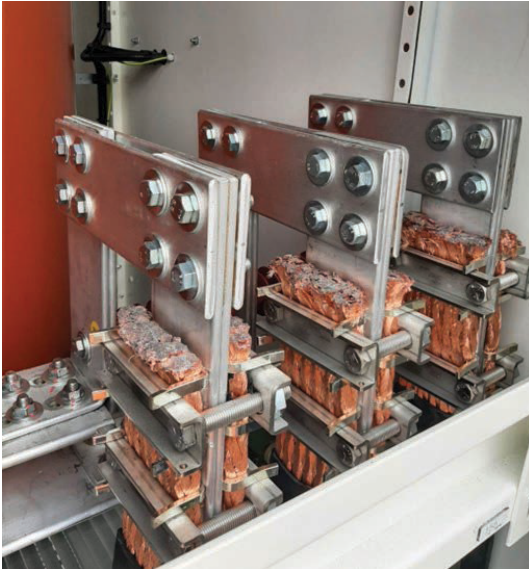

# Part Numbers

## Part Numbers and Packing Unit

### FLEXBUS CONDUCTORS



	Part Number	Global Part Number	Description	Packing Unit (pc)	Weight (kg)
	508000	FLEXCOND220L2	FleXbus Conductor 220 mm <sup>2</sup> , 2 Meter Long	1	2.5
	508001	FLEXCOND220L3	FleXbus Conductor 220 mm <sup>2</sup> , 3 Meter Long	1	3.8
	508002	FLEXCOND220L4	FleXbus Conductor 220 mm <sup>2</sup> , 4 Meter Long	1	5.1
	508003	FLEXCOND220L5	FleXbus Conductor 220 mm <sup>2</sup> , 5 Meter Long	1	6.3
	508004	FLEXCOND220L6	FleXbus Conductor 220 mm <sup>2</sup> , 6 Meter Long	1	7.6
	508005	FLEXCOND220L7	FleXbus Conductor 220 mm <sup>2</sup> , 7 Meter Long	1	8.9
	508006	FLEXCOND220L8	FleXbus Conductor 220 mm <sup>2</sup> , 8 Meter Long	1	10.1
	508007	FLEXCOND220L9	FleXbus Conductor 220 mm <sup>2</sup> , 9 Meter Long	1	11.4
	508008	FLEXCOND220L10	FleXbus Conductor 220 mm <sup>2</sup> , 10 Meter Long	1	12.7
	508210	FLEXCOND220L11	FleXbus Conductor 220 mm <sup>2</sup> , 11 Meter Long	1	13.9
	508211	FLEXCOND220L12	FleXbus Conductor 220 mm <sup>2</sup> , 12 Meter Long	1	15.1
	508212	FLEXCOND220L13	FleXbus Conductor 220 mm <sup>2</sup> , 13 Meter Long	1	16.4
	508213	FLEXCOND220L14	FleXbus Conductor 220 mm <sup>2</sup> , 14 Meter Long	1	17.6
	508214	FLEXCOND220L15	FleXbus Conductor 220 mm <sup>2</sup> , 15 Meter Long	1	18.9
	508215	FLEXCOND220L16	FleXbus Conductor 220 mm <sup>2</sup> , 16 Meter Long	1	20.2
	508216	FLEXCOND220L17	FleXbus Conductor 220 mm <sup>2</sup> , 17 Meter Long	1	21.4
	508217	FLEXCOND220L18	FleXbus Conductor 220 mm <sup>2</sup> , 18 Meter Long	1	22.7
	508218	FLEXCOND220L19	FleXbus Conductor 220 mm <sup>2</sup> , 19 Meter Long	1	23.9
	508219	FLEXCOND220L20	FleXbus Conductor 220 mm <sup>2</sup> , 20 Meter Long	1	25.2
	508220	FLEXCOND220L21	FleXbus Conductor 220 mm <sup>2</sup> , 21 Meter Long	1	26.5
	508221	FLEXCOND220L22	FleXbus Conductor 220 mm <sup>2</sup> , 22 Meter Long	1	27.7
	508222	FLEXCOND220L23	FleXbus Conductor 220 mm <sup>2</sup> , 23 Meter Long	1	29
	508223	FLEXCOND220L24	FleXbus Conductor 220 mm <sup>2</sup> , 24 Meter Long	1	30.2
	508224	FLEXCOND220L25	FleXbus Conductor 220 mm <sup>2</sup> , 25 Meter Long	1	31.5
	508010	FLEXCOND360L2	FleXbus Conductor 360 mm <sup>2</sup> , 2 Meter Long	1	3.7
	508011	FLEXCOND360L3	FleXbus Conductor 360 mm <sup>2</sup> , 3 Meter Long	1	5.5
	508012	FLEXCOND360L4	FleXbus Conductor 360 mm <sup>2</sup> , 4 Meter Long	1	7.3
	508013	FLEXCOND360L5	FleXbus Conductor 360 mm <sup>2</sup> , 5 Meter Long	1	9.2
	508014	FLEXCOND360L6	FleXbus Conductor 360 mm <sup>2</sup> , 6 Meter Long	1	11.0
	508015	FLEXCOND360L7	FleXbus Conductor 360 mm <sup>2</sup> , 7 Meter Long	1	12.9
	508016	FLEXCOND360L8	FleXbus Conductor 360 mm <sup>2</sup> , 8 Meter Long	1	14.7
	508017	FLEXCOND360L9	FleXbus Conductor 360 mm <sup>2</sup> , 9 Meter Long	1	16.5
	508018	FLEXCOND360L10	FleXbus Conductor 360 mm <sup>2</sup> , 10 Meter Long	1	18.4
	508230	FLEXCOND360L11	FleXbus Conductor 360 mm <sup>2</sup> , 11 Meter Long	1	20.2
	508231	FLEXCOND360L12	FleXbus Conductor 360 mm <sup>2</sup> , 12 Meter Long	1	22.1
	508232	FLEXCOND360L13	FleXbus Conductor 360 mm <sup>2</sup> , 13 Meter Long	1	23.9
	508233	FLEXCOND360L14	FleXbus Conductor 360 mm <sup>2</sup> , 14 Meter Long	1	25.8
	508234	FLEXCOND360L15	FleXbus Conductor 360 mm <sup>2</sup> , 15 Meter Long	1	27.6
	508235	FLEXCOND360L16	FleXbus Conductor 360 mm <sup>2</sup> , 16 Meter Long	1	29.4
	508236	FLEXCOND360L17	FleXbus Conductor 360 mm <sup>2</sup> , 17 Meter Long	1	31.3
	508237	FLEXCOND360L18	FleXbus Conductor 360 mm <sup>2</sup> , 18 Meter Long	1	33.1
	508238	FLEXCOND360L19	FleXbus Conductor 360 mm <sup>2</sup> , 19 Meter Long	1	35
	508239	FLEXCOND360L20	FleXbus Conductor 360 mm <sup>2</sup> , 20 Meter Long	1	36.8
	508240	FLEXCOND360L21	FleXbus Conductor 360 mm <sup>2</sup> , 21 Meter Long	1	38.6
	508241	FLEXCOND360L22	FleXbus Conductor 360 mm <sup>2</sup> , 22 Meter Long	1	40.5

nVent.com/ERIFLEX | 27

General Information

Technical Data

Other Data

# Part Numbers

## Part Numbers and Packing Unit

### FLEXBUS CONDUCTORS



Part Number	Global Part Number	Description	Packing Unit (pc)	Weight (kg)
508242	FLEXCOND360L23	Flexbus Conductor 360 mm <sup>2</sup> , 23 Meter Long	1	42.3
508243	FLEXCOND360L24	Flexbus Conductor 360 mm <sup>2</sup> , 24 Meter Long	1	44.2
508244	FLEXCOND360L25	Flexbus Conductor 360 mm <sup>2</sup> , 25 Meter Long	1	46
508020	FLEXCOND545L2	Flexbus Conductor 545 mm <sup>2</sup> , 2 Meter Long	1	5.2
508021	FLEXCOND545L3	Flexbus Conductor 545 mm <sup>2</sup> , 3 Meter Long	1	7.8
508022	FLEXCOND545L4	Flexbus Conductor 545 mm <sup>2</sup> , 4 Meter Long	1	10.3
508023	FLEXCOND545L5	Flexbus Conductor 545 mm <sup>2</sup> , 5 Meter Long	1	12.9
508024	FLEXCOND545L6	Flexbus Conductor 545 mm <sup>2</sup> , 6 Meter Long	1	15.5
508025	FLEXCOND545L7	Flexbus Conductor 545 mm <sup>2</sup> , 7 Meter Long	1	18.1
508026	FLEXCOND545L8	Flexbus Conductor 545 mm <sup>2</sup> , 8 Meter Long	1	20.7
508027	FLEXCOND545L9	Flexbus Conductor 545 mm <sup>2</sup> , 9 Meter Long	1	23.3
508028	FLEXCOND545L10	Flexbus Conductor 545 mm <sup>2</sup> , 10 Meter Long	1	25.8
508250	FLEXCOND545L11	Flexbus Conductor 545 mm <sup>2</sup> , 11 Meter Long	1	28.3
508251	FLEXCOND545L12	Flexbus Conductor 545 mm <sup>2</sup> , 12 Meter Long	1	30.8
508252	FLEXCOND545L13	Flexbus Conductor 545 mm <sup>2</sup> , 13 Meter Long	1	33.4
508253	FLEXCOND545L14	Flexbus Conductor 545 mm <sup>2</sup> , 14 Meter Long	1	36
508254	FLEXCOND545L15	Flexbus Conductor 545 mm <sup>2</sup> , 15 Meter Long	1	38.6
508255	FLEXCOND545L16	Flexbus Conductor 545 mm <sup>2</sup> , 16 Meter Long	1	41.1
508256	FLEXCOND545L17	Flexbus Conductor 545 mm <sup>2</sup> , 17 Meter Long	1	43.7
508257	FLEXCOND545L18	Flexbus Conductor 545 mm <sup>2</sup> , 18 Meter Long	1	46.3
508258	FLEXCOND545L19	Flexbus Conductor 545 mm <sup>2</sup> , 19 Meter Long	1	48.8
508259	FLEXCOND545L20	Flexbus Conductor 545 mm <sup>2</sup> , 20 Meter Long	1	51.4
508260	FLEXCOND545L21	Flexbus Conductor 545 mm <sup>2</sup> , 21 Meter Long	1	54
508261	FLEXCOND545L22	Flexbus Conductor 545 mm <sup>2</sup> , 22 Meter Long	1	56.5
508262	FLEXCOND545L23	Flexbus Conductor 545 mm <sup>2</sup> , 23 Meter Long	1	59.1
508263	FLEXCOND545L24	Flexbus Conductor 545 mm <sup>2</sup> , 24 Meter Long	1	61.7
508264	FLEXCOND545L25	Flexbus Conductor 545 mm <sup>2</sup> , 25 Meter Long	1	64.3
508030	FLEXCOND640L2	Flexbus Conductor 640 mm <sup>2</sup> , 2 Meter Long	1	5.9
508031	FLEXCOND640L3	Flexbus Conductor 640 mm <sup>2</sup> , 3 Meter Long	1	8.8
508032	FLEXCOND640L4	Flexbus Conductor 640 mm <sup>2</sup> , 4 Meter Long	1	11.8
508033	FLEXCOND640L5	Flexbus Conductor 640 mm <sup>2</sup> , 5 Meter Long	1	14.7
508034	FLEXCOND640L6	Flexbus Conductor 640 mm <sup>2</sup> , 6 Meter Long	1	17.7
508035	FLEXCOND640L7	Flexbus Conductor 640 mm <sup>2</sup> , 7 Meter Long	1	20.6
508036	FLEXCOND640L8	Flexbus Conductor 640 mm <sup>2</sup> , 8 Meter Long	1	23.6
508037	FLEXCOND640L9	Flexbus Conductor 640 mm <sup>2</sup> , 9 Meter Long	1	26.5
508038	FLEXCOND640L10	Flexbus Conductor 640 mm <sup>2</sup> , 10 Meter Long	1	29.5
508270	FLEXCOND640L11	Flexbus Conductor 640 mm <sup>2</sup> , 11 Meter Long	1	32.3
508271	FLEXCOND640L12	Flexbus Conductor 640 mm <sup>2</sup> , 12 Meter Long	1	35.3
508272	FLEXCOND640L13	Flexbus Conductor 640 mm <sup>2</sup> , 13 Meter Long	1	38.2
508273	FLEXCOND640L14	Flexbus Conductor 640 mm <sup>2</sup> , 14 Meter Long	1	41.2
508274	FLEXCOND640L15	Flexbus Conductor 640 mm <sup>2</sup> , 15 Meter Long	1	44.1
508275	FLEXCOND640L16	Flexbus Conductor 640 mm <sup>2</sup> , 16 Meter Long	1	47
508276	FLEXCOND640L17	Flexbus Conductor 640 mm <sup>2</sup> , 17 Meter Long	1	50
508277	FLEXCOND640L18	Flexbus Conductor 640 mm <sup>2</sup> , 18 Meter Long	1	52.9
508278	FLEXCOND640L19	Flexbus Conductor 640 mm <sup>2</sup> , 19 Meter Long	1	55.9

# Part Numbers

## Part Numbers and Packing Unit

### FLEXBUS CONDUCTORS



	Part Number	Global Part Number	Description	Packing Unit (pc)	Weight (kg)
	508279	FLEXCOND640L20	FleXbus Conductor 640 mm <sup>2</sup> , 20 Meter Long	1	58.8
	508280	FLEXCOND640L21	FleXbus Conductor 640 mm <sup>2</sup> , 21 Meter Long	1	61.7
	508281	FLEXCOND640L22	FleXbus Conductor 640 mm <sup>2</sup> , 22 Meter Long	1	64.7
	508282	FLEXCOND640L23	FleXbus Conductor 640 mm <sup>2</sup> , 23 Meter Long	1	67.6
	508283	FLEXCOND640L24	FleXbus Conductor 640 mm <sup>2</sup> , 24 Meter Long	1	70.6
	508284	FLEXCOND640L25	FleXbus Conductor 640 mm <sup>2</sup> , 25 Meter Long	1	73.5
	508040	FLEXCOND960L2	FleXbus Conductor 960 mm <sup>2</sup> , 2 Meter Long	1	8.9
	508041	FLEXCOND960L3	FleXbus Conductor 960 mm <sup>2</sup> , 3 Meter Long	1	13.3
	508042	FLEXCOND960L4	FleXbus Conductor 960 mm <sup>2</sup> , 4 Meter Long	1	17.8
	508043	FLEXCOND960L5	FleXbus Conductor 960 mm <sup>2</sup> , 5 Meter Long	1	22.2
	508044	FLEXCOND960L6	FleXbus Conductor 960 mm <sup>2</sup> , 6 Meter Long	1	26.7
	508045	FLEXCOND960L7	FleXbus Conductor 960 mm <sup>2</sup> , 7 Meter Long	1	31.1
	508046	FLEXCOND960L8	FleXbus Conductor 960 mm <sup>2</sup> , 8 Meter Long	1	35.6
	508047	FLEXCOND960L9	FleXbus Conductor 960 mm <sup>2</sup> , 9 Meter Long	1	40.0
	508048	FLEXCOND960L10	FleXbus Conductor 960 mm <sup>2</sup> , 10 Meter Long	1	44.5
	508290	FLEXCOND960L11	FleXbus Conductor 960 mm <sup>2</sup> , 11 Meter Long	1	48.8
	508291	FLEXCOND960L12	FleXbus Conductor 960 mm <sup>2</sup> , 12 Meter Long	1	53.3
	508292	FLEXCOND960L13	FleXbus Conductor 960 mm <sup>2</sup> , 13 Meter Long	1	57.7
	508293	FLEXCOND960L14	FleXbus Conductor 960 mm <sup>2</sup> , 14 Meter Long	1	62.2
	508294	FLEXCOND960L15	FleXbus Conductor 960 mm <sup>2</sup> , 15 Meter Long	1	66.6
	508295	FLEXCOND960L16	FleXbus Conductor 960 mm <sup>2</sup> , 16 Meter Long	1	71
	508296	FLEXCOND960L17	FleXbus Conductor 960 mm <sup>2</sup> , 17 Meter Long	1	75.5
	508297	FLEXCOND960L18	FleXbus Conductor 960 mm <sup>2</sup> , 18 Meter Long	1	79.9
	508298	FLEXCOND960L19	FleXbus Conductor 960 mm <sup>2</sup> , 19 Meter Long	1	84.4
	508299	FLEXCOND960L20	FleXbus Conductor 960 mm <sup>2</sup> , 20 Meter Long	1	88.8
	508300	FLEXCOND960L21	FleXbus Conductor 960 mm <sup>2</sup> , 21 Meter Long	1	93.2
	508301	FLEXCOND960L22	FleXbus Conductor 960 mm <sup>2</sup> , 22 Meter Long	1	97.7
	508302	FLEXCOND960L23	FleXbus Conductor 960 mm <sup>2</sup> , 23 Meter Long	1	102.1
	508303	FLEXCOND960L24	FleXbus Conductor 960 mm <sup>2</sup> , 24 Meter Long	1	106.6
	508304	FLEXCOND960L25	FleXbus Conductor 960 mm <sup>2</sup> , 25 Meter Long	1	111

General Information

Technical Data

Other Data

# Part Numbers

## Part Numbers and Packing Unit







### FLEXBUS CONDUCTORS

	Part Number	Global Part Number	Description	Packing Unit (pc)	Weight (kg)
	508050	FLEXCOND1280L2	FleXbus Conductor 1280 mm <sup>2</sup> , 2 Meter Long	1	11.4
	508051	FLEXCOND1280L3	FleXbus Conductor 1280 mm <sup>2</sup> , 3 Meter Long	1	17.0
	508052	FLEXCOND1280L4	FleXbus Conductor 1280 mm <sup>2</sup> , 4 Meter Long	1	22.7
	508053	FLEXCOND1280L5	FleXbus Conductor 1280 mm <sup>2</sup> , 5 Meter Long	1	28.4
	508054	FLEXCOND1280L6	FleXbus Conductor 1280 mm <sup>2</sup> , 6 Meter Long	1	34.1
	508055	FLEXCOND1280L7	FleXbus Conductor 1280 mm <sup>2</sup> , 7 Meter Long	1	39.7
	508056	FLEXCOND1280L8	FleXbus Conductor 1280 mm <sup>2</sup> , 8 Meter Long	1	45.4
	508057	FLEXCOND1280L9	FleXbus Conductor 1280 mm <sup>2</sup> , 9 Meter Long	1	51.1
	508058	FLEXCOND1280L10	FleXbus Conductor 1280 mm <sup>2</sup> , 10 Meter Long	1	56.8
	508310	FLEXCOND1280L11	FleXbus Conductor 1280 mm <sup>2</sup> , 11 Meter Long	1	62.2
	508311	FLEXCOND1280L12	FleXbus Conductor 1280 mm <sup>2</sup> , 12 Meter Long	1	67.8
	508312	FLEXCOND1280L13	FleXbus Conductor 1280 mm <sup>2</sup> , 13 Meter Long	1	73.5
	508313	FLEXCOND1280L14	FleXbus Conductor 1280 mm <sup>2</sup> , 14 Meter Long	1	79.1
	508314	FLEXCOND1280L15	FleXbus Conductor 1280 mm <sup>2</sup> , 15 Meter Long	1	84.8
	508060	FLEXCOND1810L2	FleXbus Conductor 1810 mm <sup>2</sup> , 2 Meter Long	1	15.5
	508061	FLEXCOND1810L3	FleXbus Conductor 1810 mm <sup>2</sup> , 3 Meter Long	1	23.2
	508062	FLEXCOND1810L4	FleXbus Conductor 1810 mm <sup>2</sup> , 4 Meter Long	1	31.0
	508063	FLEXCOND1810L5	FleXbus Conductor 1810 mm <sup>2</sup> , 5 Meter Long	1	38.7
	508064	FLEXCOND1810L6	FleXbus Conductor 1810 mm <sup>2</sup> , 6 Meter Long	1	46.4
	508065	FLEXCOND1810L7	FleXbus Conductor 1810 mm <sup>2</sup> , 7 Meter Long	1	54.2
	508066	FLEXCOND1810L8	FleXbus Conductor 1810 mm <sup>2</sup> , 8 Meter Long	1	61.9
	508067	FLEXCOND1810L9	FleXbus Conductor 1810 mm <sup>2</sup> , 9 Meter Long	1	69.7
	508068	FLEXCOND1810L10	FleXbus Conductor 1810 mm <sup>2</sup> , 10 Meter Long	1	77.4
	508320	FLEXCOND1810L11	FleXbus Conductor 1810 mm <sup>2</sup> , 11 Meter Long	1	85
	508321	FLEXCOND1810L12	FleXbus Conductor 1810 mm <sup>2</sup> , 12 Meter Long	1	92.8
	508322	FLEXCOND1810L13	FleXbus Conductor 1810 mm <sup>2</sup> , 13 Meter Long	1	100.5
	508323	FLEXCOND1810L14	FleXbus Conductor 1810 mm <sup>2</sup> , 14 Meter Long	1	108.2
	508324	FLEXCOND1810L15	FleXbus Conductor 1810 mm <sup>2</sup> , 15 Meter Long	1	116

# Part Numbers

## Part Numbers and Packing Unit

### FLEXBUS SUPPORTS

	Part Number	Global Part Number	Description	Packing Unit (pc)	Weight (kg)
	508100	FLEXALPROF2M	FlexBus Aluminum Perforated Profile 2 Meter	4	0.9
	508101	FLEXSUPEDG50T	FlexBus Support Kit Edge for conductor 220, 360, 545 and 640 mm <sup>2</sup> , 3 Poles	1	1.244
	508102	FLEXSUPEDG50TN	FlexBus Support Kit Edge for conductor 220, 360, 545 and 640 mm <sup>2</sup> , 3 Poles + Neutral	1	1.326
	508103	FLEXSUPEDG100T	FlexBus Support Kit Edge for conductor 960, 1280 and 1810 mm <sup>2</sup> , 3 Poles	1	1.520
	508104	FLEXSUPEDG100TN	FlexBus Support Kit Edge for conductor 960, 1280 and 1810 mm <sup>2</sup> , 3 Poles + Neutral	1	2.000
	508105	FLEXSUPFLA50T	FlexBus Support Kit Flat for conductor 220, 360, 545 and 640 mm <sup>2</sup> , 3 Poles	1	1.298
	508106	FLEXSUPFLA50TN	FlexBus Support Kit Flat for conductor 220, 360, 545 and 640 mm <sup>2</sup> , 3 Poles + Neutral	1	1.645
	508107	FLEXSUPFLA100T	FlexBus Support Kit Flat for conductor 960, 1280 and 1810 mm <sup>2</sup> , 3 Poles	1	1.960
	508108	FLEXSUPFLA100TN	FlexBus Support Kit Flat for conductor 960, 1280 and 1810 mm <sup>2</sup> , 3 Poles + Neutral	1	2.306
	549410	CABS-E	BRACKET CABS – E	10	0.046
	549420	CABS-M	BRACKET CABS – M	10	0.2
	549400	CABS-T	BRACKET CABS – T	5	0.11



### PALM/EXTENDER FOR SWITCHBOARD SIDE

	Part Number	Global Part Number	Description	Packing Unit (pc)	Weight (kg)
	508110	FLEXEXT50A1	FlexBus Extender 50x10 for conductor 220, 360 and 545 mm <sup>2</sup> Type 1	1	0.476
	508111	FLEXEXT50A2	FlexBus Extender 50x10 for conductor 220, 360 and 545 mm <sup>2</sup> Type 2	1	0.552
	508112	FLEXEXT50A3	FlexBus Extender 50x10 for conductor 220, 360 and 545 mm <sup>2</sup> Type 3	1	0.832
	508113	FLEXEXT50B1	FlexBus Extender 50x10 for conductor 640 mm <sup>2</sup> Type 1	1	0.786
	508114	FLEXEXT50B2	FlexBus Extender 50x10 for conductor 640 mm <sup>2</sup> Type 2	1	0.894
	508115	FLEXEXT50B3	FlexBus Extender 50x10 for conductor 640 mm <sup>2</sup> Type 3	1	1.158
	508116	FLEXEXT1001	FlexBus Extender 100x10 for conductor 960, 1280 and 1810 mm <sup>2</sup> Type 1	1	1.82
	508117	FLEXEXT1002	FlexBus Extender 100x10 for conductor 960, 1280 and 1810 mm <sup>2</sup> Type 2	1	2.03
	508118	FLEXEXT1003	FlexBus Extender 100x10 for conductor 960, 1280 and 1810 mm <sup>2</sup> Type 3	1	2.55

# Part Numbers

## Part Numbers and Packing Unit

### IP55 CONDUCTORS ENTRY AND IP66 UPGRADE KITS

	Part Number	Global Part Number	Description	Packing Unit (pc)	Weight (kg)
	508140	FLEXCEIP55C501	FleXbus Conductor Entry IP55 for 1 conductor 220, 360, 545 and 640 mm <sup>2</sup>	1	0.6
	508141	FLEXCEIP55C1001	FleXbus Conductor Entry IP55 for 1 conductor 960, 1280 and 1810 mm <sup>2</sup>	1	0.7
	508142	FLEXCEIP55C502	FleXbus Conductor Entry IP55 for 2 conductors 220, 360, 545 and 640 mm <sup>2</sup>	1	0.8
	508143	FLEXCEIP55C1002	FleXbus Conductor Entry IP55 for 2 conductors 960, 1280 and 1810 mm <sup>2</sup>	1	1
	508144	FLEXCEIP66C50	FleXbus Conductor Entry Kit IP66 for 1 conductor 220, 360, 545 and 640 mm <sup>2</sup>	1	0.04
	508145	FLEXCEIP66C100	FleXbus Conductor Entry Kit IP66 for 1 conductor 960, 1280 and 1810 mm <sup>2</sup>	1	0.05

### FIRE BARRIER SYSTEM

	Part Number	Global Part Number	Description	Packing Unit (pc)	Weight (kg)
	508150	FLEXFOAMBARRIER	FleXbus Foam Barrier 380 ml EI120 FBS EN	6	0.725
	508151	FLEXFIREBLOCK	FleXbus Fire Barrier Blocks FBB EN	4	0.555
	508152	FLEXBANDAGE	FleXbus Insulating Bandage FIB	1	3.6
	508153	FLEXFOAMBARUL	FleXbus Foam Barrier 380 ml EI120 FBS UL	6	0.725
	508154	FLEXFIREBLOCKUL	FleXbus Fire Barrier Blocks FBB UL	12	0.555
	508155	FLEXFOAMDISPENS	FleXbus Foam Barrier Dispenser FFBD	1	1.3

### IP2X COVER/BOOTS

	Part Number	Global Part Number	Description	Packing Unit (pc)	Weight (kg)
	508160	FLEXCOVIP2XONE	FleXbus Transfo Cover IP2X for one conductor per phase	1	0.774
	508161	FLEXCOVIP2XTWO	FleXbus Transfo Cover IP2X for two conductors per phase	1	2.259

### STRIPPER CUTTER

	Part Number	Global Part Number	Description	Packing Unit (pc)	Weight (kg)
	508170	FLEXSTRIPPERCUT	FleXbus Stripper Cutter for FleXbus Conductor	10	0.028





# Part Numbers

## Part Numbers and Packing Unit

### FLEXBUS ALU RAIL CUTTER & CRIMPER

	Part Number	Global Part Number	Description	Packing Unit (pc)	Weight (kg)
	508174	FLEXALURAILCUT	Flexbus Aluminum Rail Cutter and Insert Crimper	1	13

### FLEXBUS SCISSORS

	Part Number	Global Part Number	Description	Packing Unit (pc)	Weight (kg)
	508172	FLEXSCISSOR	Flexbus Scissors to Cut Flexbus Conductor excess length	1	0.86
	508173	FLEXSHEAR	Flexbus Shears to Cut Flexbus Conductor excess length	1	0.324

### PHASE IDENTIFICATION KIT

	Part Number	Global Part Number	Description	Packing Unit (pc)	Weight (kg)
	508175	FLEXIDKIT	Flexbus Identification Kit with L1/L2/L3/N Electrical Tape & Flexbus Sticker	1	0.153

### CONTACT KIT

	Part Number	Global Part Number	Description	Packing Unit (pc)	Weight (kg)
	558310	CONT-KIT-M6X16	Contact Kit M6 x 16	100	0.012
	558340	CONT-KIT-M8X30	Contact Kit M8 x 30	100	0.028
	558370	CONT-KIT-M10X30	Contact Kit M10 x 30	100	0.052
	558410	CONT-KIT-M10X50	Contact Kit M10 x 50	100	0.062
	558440	CONT-KIT-M12X30	Contact Kit M12 x 30	100	0.081
	558460	CONT-KIT-M12X40	Contact Kit M12 x 40	100	0.09
	558480	CONT-KIT-M12X50	Contact Kit M12 x 50	100	0.097
	567880	CONTKITM12X60ZB	Contact Kit M12 x 60	100	0.104
	558490	CONT-KIT-M12X80	Contact Kit M12 x 80	100	0.15



# Part Numbers

## Part Numbers and Packing Unit

### HCBC HIGH CURRENT BUSBAR CLAMP

	Part Number	Global Part Number	Description	Packing Unit (pc)	Weight (kg)
	508190	FLEXCLAMP63	Flexbus HCBC Clamp 63 for power supply palm width 30 to 63 mm	1	0.53
	508191	FLEXCLAMP80	Flexbus HCBC Clamp 80 for power supply palm width 70 to 80 mm	1	0.84
	508192	FLEXCLAMP100	Flexbus HCBC Clamp 100 for power supply palm width 90 to 100 mm	1	0.92
	508193	FLEXCLAMP120	Flexbus HCBC Clamp 120 for power supply palm width 110 to 120 mm	1	1.00
	508194	FLEXCLAMP160	Flexbus HCBC Clamp 160 for power supply palm width 130 to 160 mm	1	1.32

### FLEXBUS PLATE FOR HCBC

	Part Number	Global Part Number	Description	Packing Unit (pc)	Weight (kg)
	508180	FLEXPLATE50	Flexbus HCBC Plate for conductor 220, 360, 545 and 640 mm <sup>2</sup>	1	0.16
	508181	FLEXPLATE100	Flexbus HCBC Plate for conductor 960, 1280 and 1810 mm <sup>2</sup>	1	0.32
	508182	FLEXPLATE50PE	Flexbus HCBC Plate for conductor 220, 360, 545 and 640 mm <sup>2</sup> with PE connection	1	0.49
	508183	FLEXPLATE100PE	Flexbus HCBC Plate for conductor 960, 1280 and 1810 mm <sup>2</sup> with PE connection	1	0.71

# Quick Selection Guide

## Mandatory Product Selection

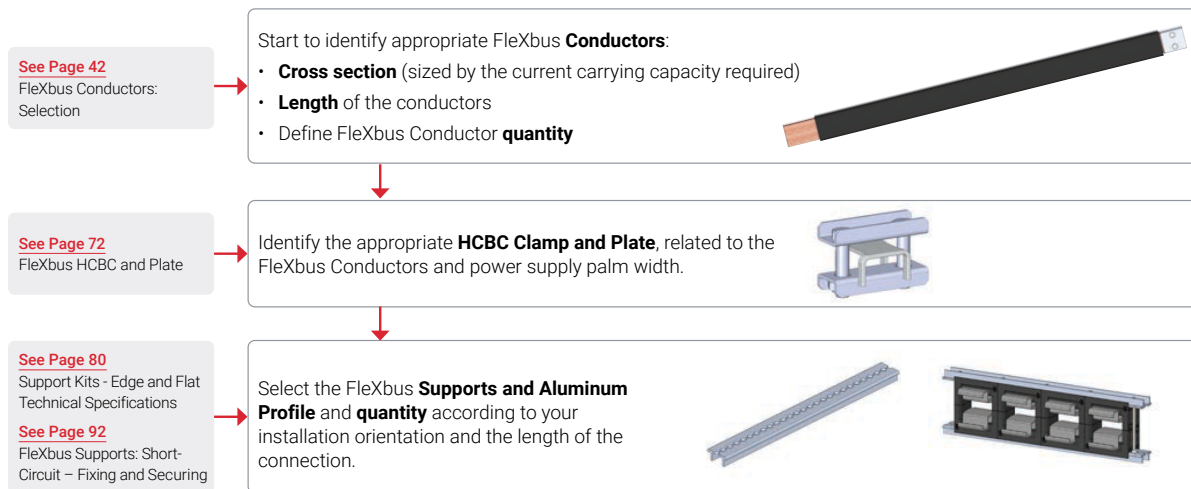

## Optional Product Selection

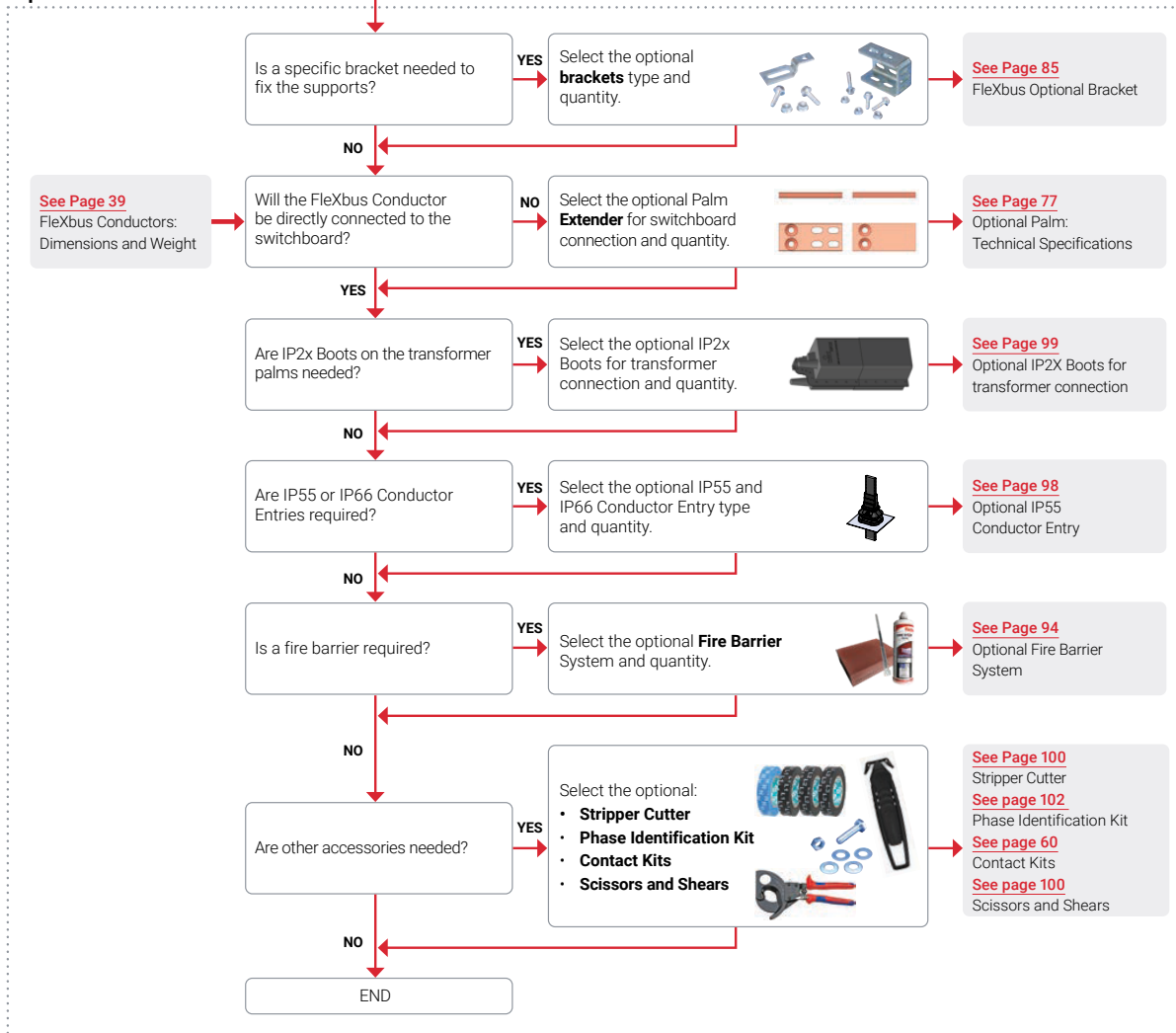

# Standards and Certifications

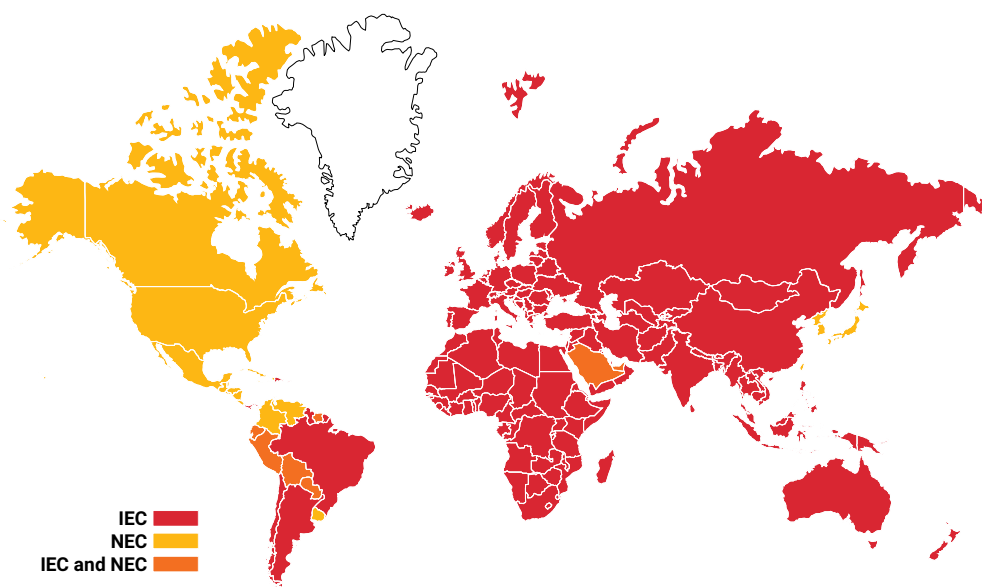















nVent ERIFLEX Flexbus has been designed and tested according to the international standard for low-voltage installations per IEC 60364, according to the European Standard HD 384 and according to the related national standards listed on the table below (non-exhaustive list).

- The IEC international standards are published and maintained by the International Electrotechnical Commission.
- The European HD standards, published and maintained by CENELEC, refer to IEC standards.
- The national standards of the European countries (NFC, VDE, BS, etc.) refer to CENELEC standards.

An electrical installation is defined as "the set of components between a power source and the consumers." The primary purposes of the installation standards are:

- To ensure the protection and safety of property against hazards (overloads, short circuits, voltage drops).
- To ensure the protection and safety of persons (risk of electric shocks).
- To ensure the continued life of the installation and facilitate its use.

National Standards	Standard	Country applying a national standard from another country (examples)
Australia 	AS 3008	
Austria 	ÖNORM	
Belgium 	RGIE - AREI	
Brazil 	NBR 5410	
Czech Republic 	CSN	
France 	NFC 15-100	Algeria, Benin, Burkina Faso, Cameroon, Central African Republic, Chad, Côte d'Ivoire, Democratic Republic of the Congo, Djibouti, French Guyana, French Polynesia, Gabon, Libya, Luxembourg, Madagascar, Mali, Mauritania, Monaco, Morocco, Niger, Republic of the Congo, Senegal, Togo, Tunisia
Germany 	DIN VDE 0100	Luxembourg
Italy 	CEI 64-8	Vatican City
Netherlands 	NEN 1010	Suriname
Portugal 	NP	Cape Verde
Spain 	REBT 2011	Andorra
Switzerland 	NIBT-NIN	
United Kingdom 	BS 7671	Botswana, Cameroon, Cyprus, Gambia, Ghana, Gibraltar, Guyana, Kenya, Lesotho, Malawi, Mauritius, Mozambique, Namibia, Nigeria, Rwanda, Seychelles, Sierra Leone, South Africa, Sri Lanka, Swaziland, Tanzania, Trinidad and Tobago, Uganda, Zambia, Zimbabwe
China 	GB 50054	
Sweden 	SS 436 40 00	
	IEC 364	Argentina, Bolivia, Chile, Ecuador, Paraguay, Peru

# Standards and Certifications

## IEC Standards and Certifications

Flexbus can be used as power conductors per IEC 60364 if not installed inside a panel board/switchboard, such as a transformer, generator or UPS connection.

Applications inside any type of enclosure are related to IEC 61439, and Flexbus can also offer advantages with space and time savings. **See page 44** for Flexbus Conductor ampacity under those two different standards.

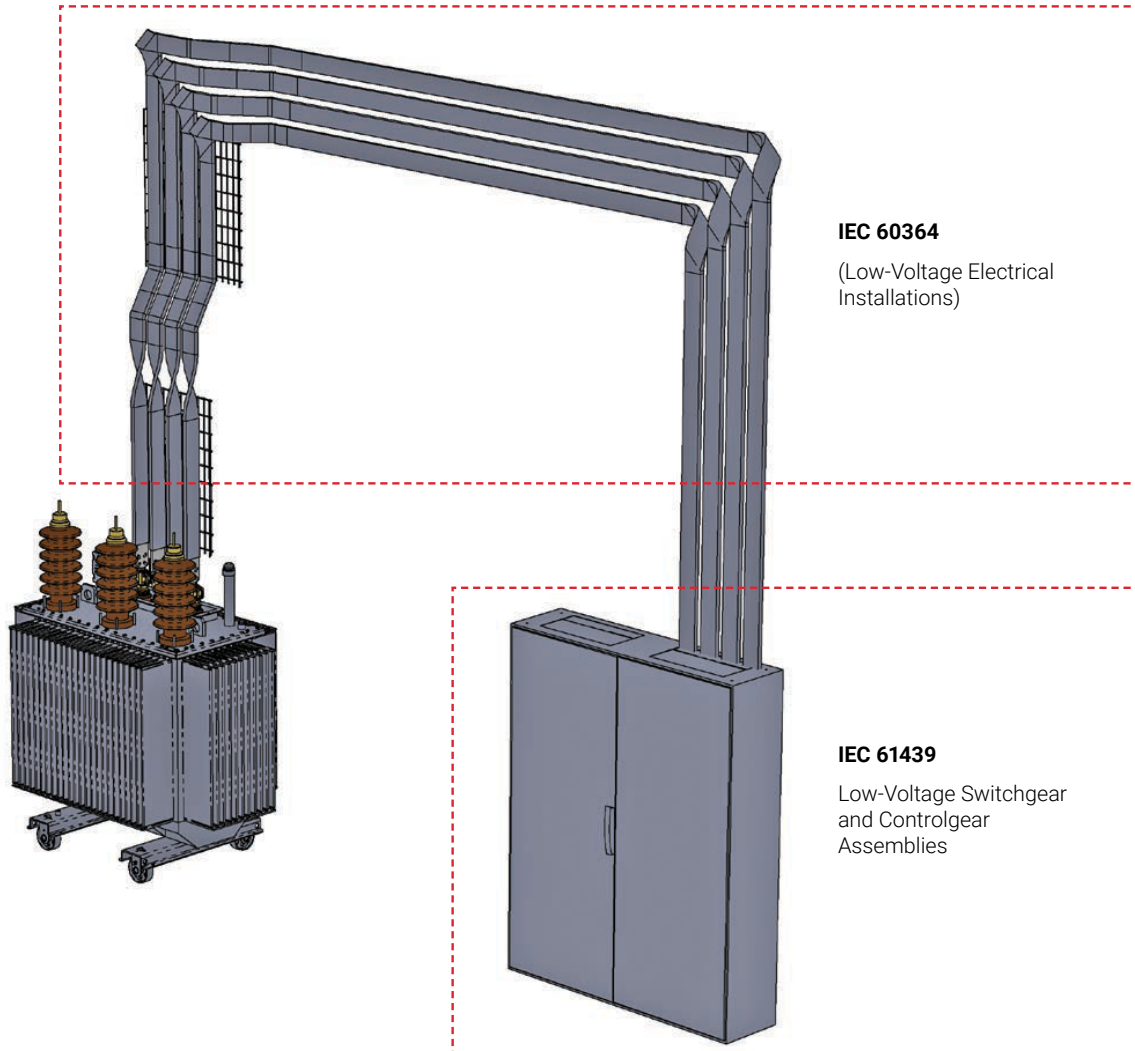

# Conductors

## Technical Specifications

FeXbus Conductors		
<b>1</b> Conductive Part	<b>Material</b>	CCA (Copper Clad Aluminum). 90% Alu/10% Copper Electrolytic copper Cu-ETP 99.9% purity
	<b>Wire Diameter</b>	0.20 mm
	<b>Maximum Resistivity at 20°C</b>	≤0.027 ohms.mm <sup>2</sup> /m
<b>2</b> Advanced Insulation	<b>Material</b>	Thermoplastic Elastomer (TPE)
	<b>Class</b>	Class II (IEC 61 439-1 chapter 8.6.4 and Table 4 and IEC 60364-4-41 chapter 410.3.3 and 412)
	<b>Mechanical Impact Resistance IK</b>	IK09
	<b>Dielectric Strength</b>	20 kV/mm
	<b>Flammability Rating</b>	UL® 94V-0 IEC® 60695-2-12 (Glow Wire Test 960°C)
	<b>Halogen-Free Rating</b>	UL® 2885 IEC® 60754-1 IEC® 62821-2
	<b>Low-Smoke Rating</b>	UL® 2885 IEC® 61034-2 ISO 5659-2
	<b>EU CPR Class</b>	Eca - s2, d2, a3
	<b>Typical Insulation Elongation</b>	> 500%
	<b>Typical Insulation Thickness</b>	3 mm
	<b>Nominal Voltage</b>	IEC: 1,000 VAC; 1,500 VDC EN50264-3-1: meets the requirements of tests 7.3, 7.5, 7.6 and 7.7 for voltages up to 6 kV AC/DC.
	<b>Working Temperature</b>	-50 to 115°C (-58 to 239°F)
	<b>Mini Installation temperature</b>	+5°C (41°F)
<b>UV Rating</b>	UL 2556 and UL 854 IEC 60364-2-52 Chapter 522.11: AN3 Level ISO 4892-2	
<b>3</b> Crimp Tube	<b>Material</b>	Copper
	<b>Finish</b>	Tinned
<b>Certifications and Compliance</b>	<b>Complies With</b>	IEC® 60695-2-12 (Glow Wire Test 960°C) IEC® 61439.1 Class II: IEC® 61439.1 and IEC 60364 CE RoHS EN 45545: HL3 classification ESTI (Swiss Confederation) EAC
	<b>International</b>	IEC 60364
<b>Installation Usage</b>	<b>Europe</b>	HD384
	<b>National</b>	AS 3008 ÔNORM RGIE – AREI NBR 5410 CSN NFC 15-100 DIN VDE 0100 CEI 64-8 NEN 1010 NP (2002) REBT SS 436 40 00 NIBT-NIN BS 7671



# Conductors

## Dimensions and Weight

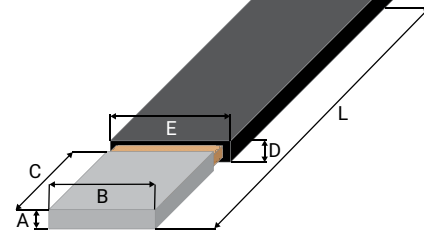

Part Number	Global Part Number	Cross Section(mm <sup>2</sup> )	L (mm)	A (mm)	B (mm)	C (mm)	D (mm)	E (mm)	Palm Dimension	Packing Unit	Weight (Kg)
508000	FLEXCOND220L2	220	2000	9	50	50	16	58		1pc	2.5
508001	FLEXCOND220L3		3000								3.8
508002	FLEXCOND220L4		4000								5.1
508003	FLEXCOND220L5		5000								6.3
508004	FLEXCOND220L6		6000								7.6
508005	FLEXCOND220L7		7000								8.9
508006	FLEXCOND220L8		8000								10.1
508007	FLEXCOND220L9		9000								11.4
508008	FLEXCOND220L10		10000								12.7
508210	FLEXCOND220L11		11000								13.9
508211	FLEXCOND220L12		12000								15.1
508212	FLEXCOND220L13		13000								16.4
508213	FLEXCOND220L14		14000								17.6
508214	FLEXCOND220L15		15000								18.9
508215	FLEXCOND220L16		16000								20.2
508216	FLEXCOND220L17		17000								21.4
508217	FLEXCOND220L18		18000								22.7
508218	FLEXCOND220L19		19000								23.9
508219	FLEXCOND220L20		20000								25.2
508220	FLEXCOND220L21		21000								26.5
508221	FLEXCOND220L22		22000								27.7
508222	FLEXCOND220L23		23000								29
508223	FLEXCOND220L24		24000								30.2
508224	FLEXCOND220L25		25000								31.5
508010	FLEXCOND360L2		360								2000
508011	FLEXCOND360L3	3000		5.5							
508012	FLEXCOND360L4	4000		7.3							
508013	FLEXCOND360L5	5000		9.2							
508014	FLEXCOND360L6	6000		11							
508015	FLEXCOND360L7	7000		12.9							
508016	FLEXCOND360L8	8000		14.7							
508017	FLEXCOND360L9	9000		16.5							
508018	FLEXCOND360L10	10000		18.4							
508230	FLEXCOND360L11	11000		20.2							
508231	FLEXCOND360L12	12000		22.1							
508232	FLEXCOND360L13	13000		23.9							
508233	FLEXCOND360L14	14000		25.8							
508234	FLEXCOND360L15	15000		27.6							
508235	FLEXCOND360L16	16000		29.4							
508236	FLEXCOND360L17	17000		31.3							
508237	FLEXCOND360L18	18000		33.1							
508238	FLEXCOND360L19	19000		35							
508239	FLEXCOND360L20	20000		36.8							
508240	FLEXCOND360L21	21000		38.6							
508241	FLEXCOND360L22	22000		40.5							
508242	FLEXCOND360L23	23000		42.3							
508243	FLEXCOND360L24	24000		44.2							
508244	FLEXCOND360L25	25000		46							

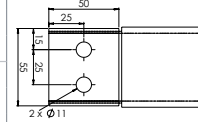

General Information

Technical Data

Other Data

# Conductors

## Dimensions and Weight

Part Number	Global Part Number	Cross Section(mm <sup>2</sup> )	L (mm)	A (mm)	B (mm)	C (mm)	D (mm)	E (mm)	Palm Dimension	Packing Unit	Weight (Kg)
508020	FLEXCOND545L2	545	2000	18	50	50	31	58		1pc	5.2
508021	FLEXCOND545L3		3000								7.8
508022	FLEXCOND545L4		4000								10.3
508023	FLEXCOND545L5		5000								12.9
508024	FLEXCOND545L6		6000								15.5
508025	FLEXCOND545L7		7000								18.1
508026	FLEXCOND545L8		8000								20.7
508027	FLEXCOND545L9		9000								23.3
508028	FLEXCOND545L10		10000								25.8
508250	FLEXCOND545L11		11000								28.3
508251	FLEXCOND545L12		12000								30.8
508252	FLEXCOND545L13		13000								33.4
508253	FLEXCOND545L14		14000								36
508254	FLEXCOND545L15		15000								38.6
508255	FLEXCOND545L16		16000								41.1
508256	FLEXCOND545L17		17000								43.7
508257	FLEXCOND545L18		18000								46.3
508258	FLEXCOND545L19		19000								48.8
508259	FLEXCOND545L20		20000								51.4
508260	FLEXCOND545L21		21000								54
508261	FLEXCOND545L22		22000								56.5
508262	FLEXCOND545L23		23000								59.1
508263	FLEXCOND545L24		24000								61.7
508264	FLEXCOND545L25		25000								64.3
508030	FLEXCOND640L2		640								2000
508031	FLEXCOND640L3	3000		8.8							
508032	FLEXCOND640L4	4000		11.8							
508033	FLEXCOND640L5	5000		14.7							
508034	FLEXCOND640L6	6000		17.7							
508035	FLEXCOND640L7	7000		20.6							
508036	FLEXCOND640L8	8000		23.6							
508037	FLEXCOND640L9	9000		26.5							
508038	FLEXCOND640L10	10000		29.5							
508270	FLEXCOND640L11	11000		32.3							
508271	FLEXCOND640L12	12000		35.3							
508272	FLEXCOND640L13	13000		38.2							
508273	FLEXCOND640L14	14000		41.2							
508274	FLEXCOND640L15	15000		44.1							
508275	FLEXCOND640L16	16000		47							
508276	FLEXCOND640L17	17000		50							
508277	FLEXCOND640L18	18000		52.9							
508278	FLEXCOND640L19	19000		55.9							
508279	FLEXCOND640L20	20000		58.8							
508280	FLEXCOND640L21	21000		61.7							
508281	FLEXCOND640L22	22000		64.7							
508282	FLEXCOND640L23	23000		67.6							
508283	FLEXCOND640L24	24000		70.6							
508284	FLEXCOND640L25	25000		73.5							



# Conductors

## Dimensions and Weight

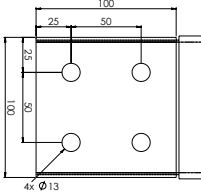
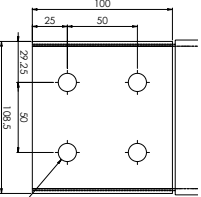
Part Number	Global Part Number	Cross Section(mm <sup>2</sup> )	L (mm)	A (mm)	B (mm)	C (mm)	D (mm)	E (mm)	Palm Dimension	Packing Unit	Weight (Kg)
508040	FLEXCOND960L2	960	2000	14.8	100	100	28	108		1pc	8.9
508041	FLEXCOND960L3		3000								13.3
508042	FLEXCOND960L4		4000								17.8
508043	FLEXCOND960L5		5000								22.2
508044	FLEXCOND960L6		6000								26.7
508045	FLEXCOND960L7		7000								31.1
508046	FLEXCOND960L8		8000								35.6
508047	FLEXCOND960L9		9000								40
508048	FLEXCOND960L10		10000								44.5
508290	FLEXCOND960L11		11000								48.8
508291	FLEXCOND960L12		12000								53.3
508292	FLEXCOND960L13		13000								57.7
508293	FLEXCOND960L14		14000								62.2
508294	FLEXCOND960L15		15000								66.6
508295	FLEXCOND960L16		16000								71
508296	FLEXCOND960L17		17000								75.5
508297	FLEXCOND960L18		18000								79.9
508298	FLEXCOND960L19		19000								84.4
508299	FLEXCOND960L20		20000								88.8
508300	FLEXCOND960L21		21000								93.2
508301	FLEXCOND960L22		22000								97.7
508302	FLEXCOND960L23		23000								102.1
508303	FLEXCOND960L24		24000								106.6
508304	FLEXCOND960L25		25000								111
508050	FLEXCOND1280L2		1280								2000
508051	FLEXCOND1280L3	3000		17							
508052	FLEXCOND1280L4	4000		22.7							
508053	FLEXCOND1280L5	5000		28.4							
508054	FLEXCOND1280L6	6000		34.1							
508055	FLEXCOND1280L7	7000		39.7							
508056	FLEXCOND1280L8	8000		45.4							
508057	FLEXCOND1280L9	9000		51.1							
508058	FLEXCOND1280L10	10000		56.8							
508310	FLEXCOND1280L11	11000		62.2							
508311	FLEXCOND1280L12	12000		67.8							
508312	FLEXCOND1280L13	13000		73.5							
508313	FLEXCOND1280L14	14000		79.1							
508314	FLEXCOND1280L15	15000		84.8							
508060	FLEXCOND1810L2	1810		2000	25	109	100	39	108		1pc
508061	FLEXCOND1810L3		3000	23.2							
508062	FLEXCOND1810L4		4000	31							
508063	FLEXCOND1810L5		5000	38.7							
508064	FLEXCOND1810L6		6000	46.4							
508065	FLEXCOND1810L7		7000	54.2							
508066	FLEXCOND1810L8		8000	61.9							
508067	FLEXCOND1810L9		9000	69.7							
508068	FLEXCOND1810L10		10000	77.4							
508320	FLEXCOND1810L11		11000	85							
508321	FLEXCOND1810L12		12000	92.8							
508322	FLEXCOND1810L13		13000	100.5							
508323	FLEXCOND1810L14		14000	108.2							
508324	FLEXCOND1810L15		15000	116							

General Information

Technical Data

Other Data

# Conductors

## Selection

### HOW TO SIZE FLEXBUS CONDUCTORS

The chart below demonstrates the general steps to selecting FlexBus Conductor sizes.

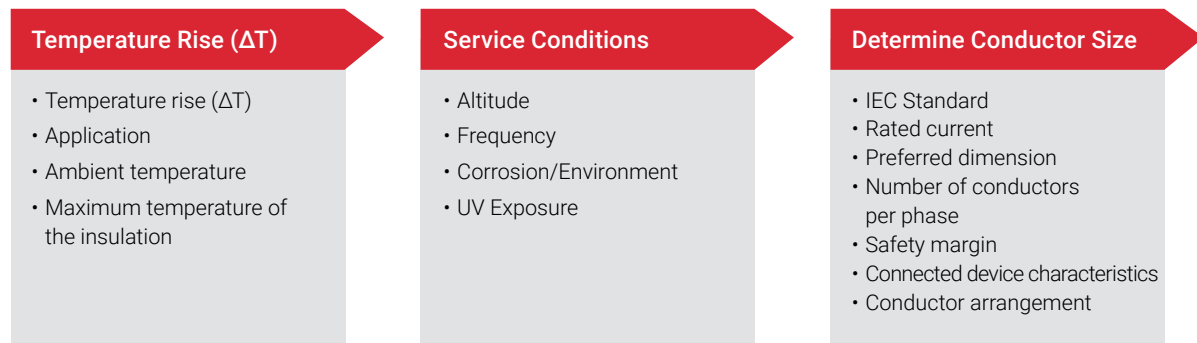

### TEMPERATURE RISE OF THE FLEXBUS CONDUCTORS

Temperature rise of the Flexbus Conductor ( $\Delta T$ ) = Temperature of the conductor – Ambient temperature around conductor

Temperature rise of conductor =  $T_2 - T_1 = \Delta T$  (K)

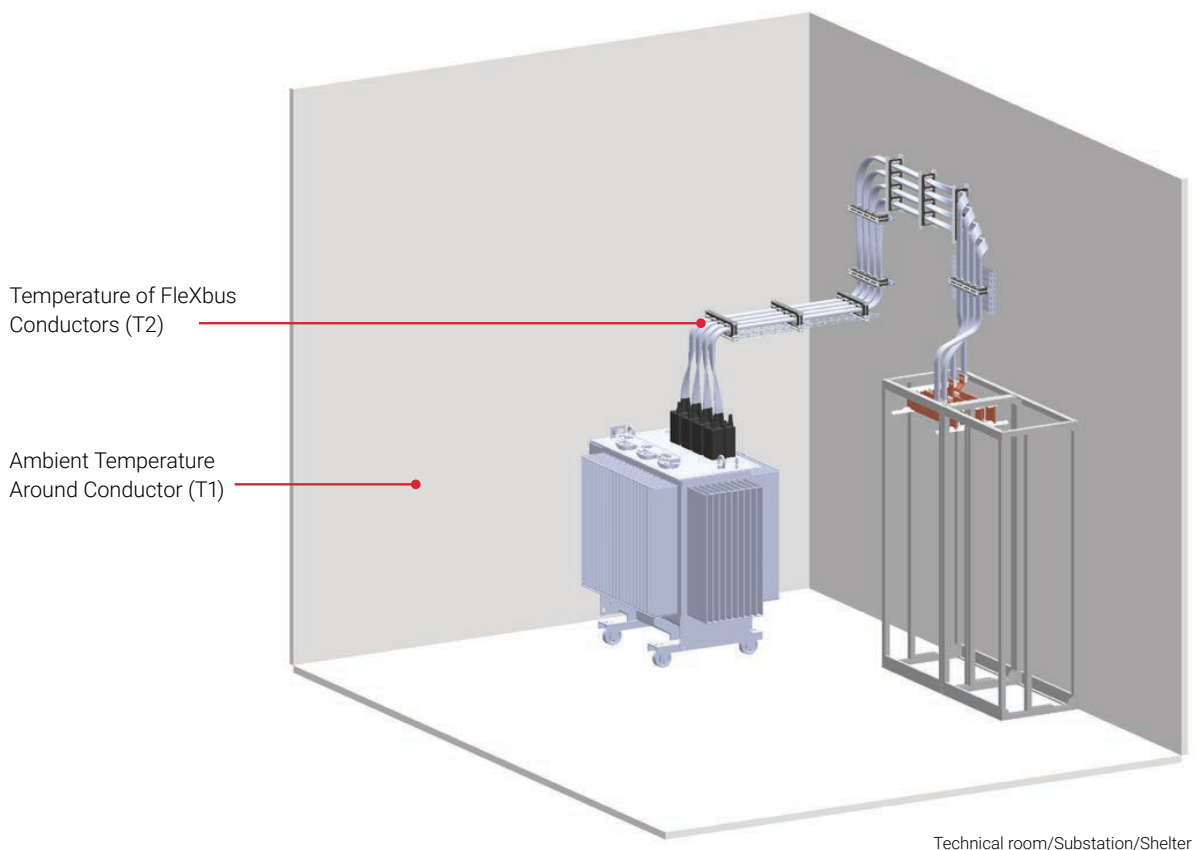

# Conductors

## Selection

### SELECTION OF FLEXBUS CONDUCTORS ACCORDING TO THE AMBIENT TEMPERATURE

The air temperature around the conductor (ambient temperature) is a very important parameter when sizing a conductor. Factors such as convection type, temperature rise and more, all affect the selection of conductor size.

The table on the next page shows ampacity under different temperature rises. A lower temperature rise may be used when the ambient temperature is higher than usual. It is recommended that the maximum temperature rise ( $\Delta T$ ) does not exceed 60K for a normal application when using Flexbus Conductors.

Generally, 60K is chosen as the default temperature rise, considering the ambient temperature is 30°C. But when the connected part is an electrical component that may dissipate heat (for example circuit breaker), or the ventilation inside the

enclosure is not efficient, it may be necessary to choose a lower temperature rise.

The Flexbus Conductors' Advanced Technology has a maximum working temperature of 115°C. However, according to IEC 60364 Low-Voltage Electrical Installations, Part 5-52 (Selection and Erection of Electrical Equipment – Wiring Systems, Chapter 522.1.1 and Table 52-1), we recommend not exceeding 90°C at the conductor, despite IEC allowing the use of manufacturer data.

**Note:** If a Flexbus Conductor is used inside a panel/switchboard, according to IEC 61439 Standard, please contact our sales representative for the specific ampacities/current table.

### STANDARD REFERENCE: IEC 60364 (LOW-VOLTAGE INSTALLATIONS)



**Table 52.1 – Maximum operating temperatures for types of insulation**

Type of Insulation	Temperature Limit a, d (°C)
Thermoplastic (PVC)	70 at the conductor
Thermosetting (XLPE or EPR rubber)	90 at the conductor b
Mineral (thermoplastic (PVC) covered or bare exposed to touch)	70 at the sheath
Mineral (bare not exposed to touch and not in contact with combustible material)	105 at the sheath b, c

a The maximum permissible conductor temperatures given in Table 52.1 on which the tabulated current-carrying capacities given in Annex A are based, have been taken from IEC 60502 and IEC 60702 and are shown on these tables.

b Where a conductor operates at a temperature exceeding 70°C, it shall be ascertained that the equipment connected to the conductor is suitable for the resulting temperature at the connection.

c For mineral insulated cables, higher operating temperatures may be permissible dependent upon the temperature rating of the cable, its terminations, the environmental conditions and other external influences.

d Where certified, conductors or cables may have maximum operating temperature limits in accordance with the manufacturer's specification.

**NOTE 1** The table does not include all types of cables.

**NOTE 2** For the temperature limit for other types of insulation, please refer to cable specification or manufacturer.

522.1.2 Wiring system components including cables and wiring accessories shall only be installed or handled at temperatures within the limits stated in the relevant product standard or as given by the manufacturer.

#### B.52.2 Ambient temperature:

B.52.2.1 the current-carrying capacities tabulated in this annex assume the following reference ambient temperatures:

For insulated conductors and cables in air, irrespective of the method of installation: 30°C

### DERATING FACTOR TO USE FOR FLEXBUS CONDUCTORS IN PARALLEL

For applications according to IEC 60364 Low-Voltage Electrical Installations and typically for transformer or generator connection, with recommended conductor arrangement respected, there is no derating to apply. By consequence, the current coefficient to apply is 2.

For applications according to IEC 61439 Low-Voltage Switchgear and Controlgear Assemblies when Flexbus Conductors are used inside any type of panel and a cable arrangement is not possible due to the conductor's short length, the current coefficient with two conductors in parallel on the same phase is between 1.48 to 1.56.

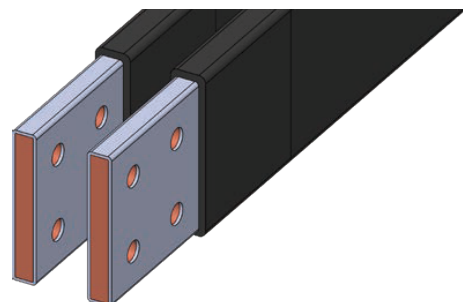

# Conductors

## Ampacity



Flexbus Conductor Type	Cross Section mm <sup>2</sup>	Maximum Current Ratings**									Current Coefficient with 2 conductors per phase and with conductor arrangement respected*	Current Coefficient with 2 conductors per phase and with conductor arrangement not respected*	Current Coefficient with 3 conductors per phase and with conductor arrangement respected*	Current Coefficient with 3 conductors per phase and with conductor arrangement not respected*
		ΔT 30 K (Coef & A)	ΔT 40 K (Coef & A)	ΔT 45 K (Coef & A)	ΔT 50 K (Coef & A)	ΔT 55 K (Coef & A)	ΔT 60 K (Coef & A)	ΔT 65 K (Coef & A)	ΔT 70 K (Coef & A)					
		60°C Ambient 90°C at Conductor	50°C Ambient 90°C at Conductor	45°C Ambient 90°C at Conductor	40°C Ambient 90°C at Conductor	35°C Ambient 90°C at Conductor	30°C Ambient 90°C at Conductor	25°C Ambient 90°C at Conductor	20°C Ambient 90°C at Conductor					
FLEXCOND220	220	473 A	546 A	579 A	606 A	639 A	666 A	693 A	719 A	2	1.56	2.85	1.95	
FLEXCOND360	360	640 A	739 A	784 A	820 A	865 A	901 A	937 A	973 A	2	1.52	2.80	1.87	
FLEXCOND545	545	800 A	924 A	980 A	1026 A	1082 A	1127 A	1172 A	1217 A	2	1.51	2.77	1.81	
FLEXCOND640	640	0.71 875 A	0.82 1011 A	0.87 1073 A	0.91 1122 A	0.96 1184 A	1 1233 A	1.04 1282 A	1.08 1332 A	2	1.51	2.75	1.8	
FLEXCOND960	960	1250 A	1444 A	1532 A	1603 A	1691 A	1761 A	1831 A	1902 A	2	1.48	2.71	1.72	
FLEXCOND1280	1280	1409 A	1627 A	1726 A	1805 A	1905 A	1984 A	2063 A	2143 A	2	1.48	2.70	1.7	
FLEXCOND1810	1810	1673 A	1932 A	2050 A	2144 A	2262 A	2356 A	2450 A	2544 A	2	1.48	2.70	1.64	

\* For 2 or 3 Flexbus Conductors per phase, see Chapter 2 & 3 Flexbus Conductors per phase – recommended configuration (Conductor arrangement).  
 \*\* Correction factor for ambient air temperatures other than 30°C to be applied to the current-carrying capacities for cables in the air (From table B.52.14 of IEC 60364-5-52).  
**Note:** Those current and derating factor are valid for conductor either Flat or on Edge position.  
 \*\* In DC current, there is no derating to be applied due to the skin effect.  
 The total current in the phase is equal to the current in one conductor multiplied by the number of conductors.

For Applications according to the IEC 60364 Low-Voltage Electrical Installations

### 2 OR 3 FLEXBUS CONDUCTORS PER PHASE – (CONDUCTOR ARRANGEMENT) MAGNETIC FIELD PHENOMENA

In industrial and commercial power distribution systems, single-core power cables are often connected in parallel to meet the high ampacity requirement of low-voltage main feeders. However, parallel-connected cables have unequal current sharing between the cables of the same phase; some of the cables may be heavily loaded, while some are in light loading condition even though all of them belong to the same phase. This phenomenon of unequal current distribution may cause excessive temperature increase in the overloaded cables. It is well known that the increase of cable temperature can reduce the life expectancy of cable insulation.

The fields of cables carrying AC currents interact with each other depending on the magnitude of the current they carry, their separation and their relative phase angle. The resultant and combined magnetic field caused by conductors can be problematic since it can be a health and safety concern for people working nearby; increases electrical losses and hence reduces the conductor current ratings; and causes current-sharing unbalance where multiple cables per phase are used. The relative positions of the conductors of different phases—L1, L2 and L3—can be easily optimized to minimize the magnetic field with a range of benefits.

#### Example of magnetic field result in function of conductor arrangement:



**Optimized** Conductor Arrangement  
(Load current balanced)

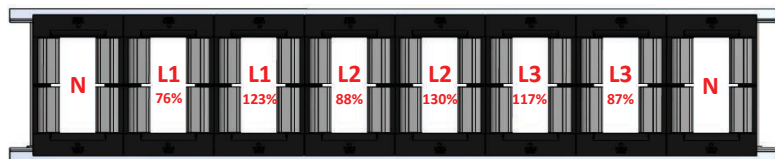

**Non-Optimized** Conductor Arrangement  
(Load current unbalanced)

# Conductors

## Conductor Arrangement

### 2 OR 3 FLEXBUS CONDUCTORS PER PHASE – RECOMMENDED CONFIGURATION (CONDUCTOR ARRANGEMENT)

In the case of a 2 or 3 Flexbus Conductors per phase configuration (for example for power supply 2000, 2500 and 3150 kVA connection), in order to reduce electrodynamic forces in case of short-circuit and to increase current flow

(reduce skin effect) and limit the impedance difference, we recommend to installing the different conductors as shown below. These configurations allow a well-balanced current load.

	Optimized conductors arrangement (Load current balanced)	Non-Optimized conductors arrangement (Load current unbalanced)
2 Flexbus conductors per phase		
3 Flexbus conductors per phase		



#### Standard reference:

IEC 60364 Low-Voltage Electrical Installations – 523.7 Conductors in parallel

Where two or more live conductors or PEN conductors are connected in parallel in a system, either:

Measures shall be taken to achieve equal load current sharing between them;

This requirement is considered to be fulfilled if the conductors are of the same material, have the same cross-sectional area, are approximately the same length and have no branch circuits along the length.

If the conductors in parallel are non-twisted single-core cables or insulated conductors in trefoil or in flat formation and have a cross-sectional area greater than 50 mm<sup>2</sup> in copper or 70 mm<sup>2</sup> in aluminum, the special configuration necessary for such formations is adopted. These configurations consist of suitable groupings and spacing of the different phases or poles (see Annex H).

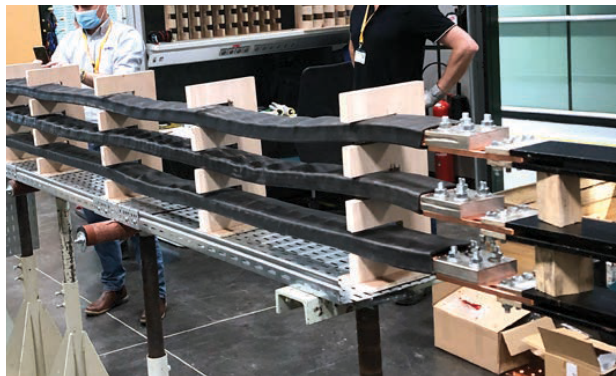

Temperature rise test sequence pictures and probe/temperature sensor all along the installation

Extract from Annex H from IEC 60364 Low-Voltage Electrical Installations – 523.7 Conductors in Parallel

#### Examples of configurations of parallel cables

The special configurations referred to in 523.7 can be:

- for 4 three-core cables the connection scheme: L<sub>1</sub> L<sub>2</sub> L<sub>3</sub>, L<sub>1</sub> L<sub>2</sub> L<sub>3</sub>, L<sub>1</sub> L<sub>2</sub> L<sub>3</sub>, L<sub>1</sub> L<sub>2</sub> L<sub>3</sub>; the cables may be touching;
- for 6 single-core cables
  - in a flat plane, see Figure H.52.1.
  - above each other, see Figure H.52.2.
  - in trefoil, see Figure H.52.3;
- for 9 single-core cables
  - in a flat plane, see Figure H.52.4.
  - above each other, see Figure H.52.5.
  - in trefoil, see Figure H.52.6;
- for 12 single-core cables
  - in a flat plane, see Figure H.52.7.
  - above each other, see Figure H.52.8.
  - in trefoil, see Figure H.52.9.

The distances in these figures shall be maintained.

NOTE Where possible, the impedance differences between the phases are also limited in the special configurations.

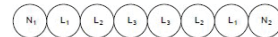

Figure H.52.1 – Special configuration for 6 parallel single-core cables in a flat plane (see 523.7)



Figure H.52.2 – Special configuration for 6 parallel single-core cables above each other (see 523.7)

# Conductors

## Cooling and Spacing Between Conductors

FleXbus Conductors have been designed and tested to be supported with our FleXbus supports.

These supports allow a proper distance (D) between conductors for air cooling. This distance is provided by the FleXbus supports and should be respected all along the FleXbus Conductors.

FleXbus Conductors should not be tightened together with plastic ties and without spacing.

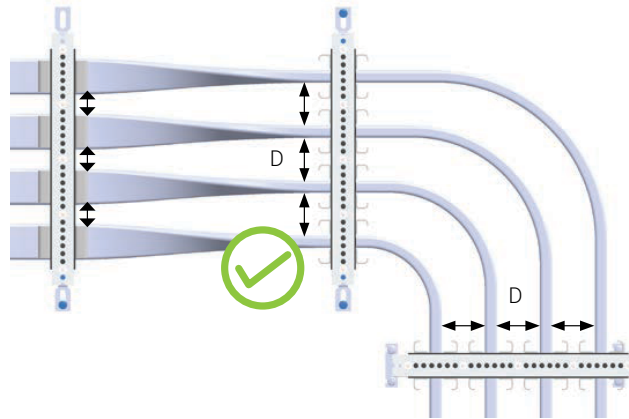
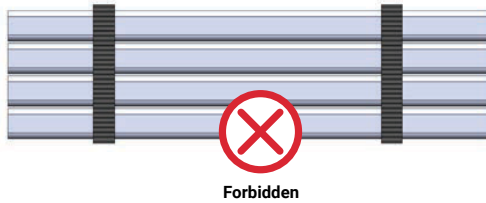

## Recommendation for Transformer Connections

Transformer Power	Transformer LV Current In (A) at 410 V at secondary*	Recommended FleXbus conductors per phase (Qty and Cross section)			
		30°C Ambient	40°C Ambient	50°C Ambient	
	400 kVA	560	1x220 mm <sup>2</sup>	1x220 mm <sup>2</sup>	1x360 mm <sup>2</sup>
	500 kVA	704	1x360 mm <sup>2</sup>	1x360 mm <sup>2</sup>	1x360 mm <sup>2</sup>
	630 kVA	900	1x360 mm <sup>2</sup>	1x545 mm <sup>2</sup>	1x545 mm <sup>2</sup>
	800 kVA	1120	1x545 mm <sup>2</sup>	1x640 mm <sup>2</sup>	1x960 mm <sup>2</sup> or 2x360 mm <sup>2</sup>
	1000 kVA	1400	1x960 mm <sup>2</sup> or 2x360 mm <sup>2</sup>	1x960 mm <sup>2</sup> or 2x360 mm <sup>2</sup>	1x960 mm <sup>2</sup> or 2x360 mm <sup>2</sup>
	1250 kVA	1760	1x960 mm <sup>2</sup> or 2x360 mm <sup>2</sup>	1x1280 mm <sup>2</sup> or 2x545 mm <sup>2</sup>	1x1810 mm <sup>2</sup> or 2x545 mm <sup>2</sup>
	1600 kVA	2253	1x1810 mm <sup>2</sup> or 2x545 mm <sup>2</sup>	2x960 mm <sup>2</sup> or 3x360 mm <sup>2</sup>	2x960 mm <sup>2</sup> or 3x545 mm <sup>2</sup>
	2000 kVA	2816	2x960 mm <sup>2</sup> or 3x545 mm <sup>2</sup>	2x960 mm <sup>2</sup> or 3x545 mm <sup>2</sup>	2x960 mm <sup>2</sup>
	2500 kVA	3520	2x960 mm <sup>2</sup>	2x1280 mm <sup>2</sup> or 3x960 mm <sup>2</sup>	2x1810 mm <sup>2</sup> or 3x960 mm <sup>2</sup>
	3150 kVA	4435	2x1810 mm <sup>2</sup> or 3x960 mm <sup>2</sup>	3x1280 mm <sup>2</sup>	*
	3600 kVA	5069	3x1280 mm <sup>2</sup>	3x1810 mm <sup>2</sup>	*
	4000 kVA	5632	3x1810 mm <sup>2</sup>	3x1810 mm <sup>2</sup>	*
4500 kVA	6336	3x1810 mm <sup>2</sup>	*	*	

Note: The IEC standard for power transformers is IEC 60076.

Note: This table is valid for 30°C, 40°C and 50°C ambient temperature (From table B.52.14 of IEC 60364-5-52).

Note: This table is valid if the recommended conductor arrangement is respected with 2 or 3 conductors per phase.

\* Please contact your nVent ERIFLEX representative

\* 3-phase transformer nominal current (In) is obtained from power (P) and voltage at secondary (U)

$$I_n = \frac{P \times 10^3}{U\sqrt{3}}$$

P: Transformer power in kVA

U: Voltage at secondary in V (410 V in the above table)

In: In Ampere (A)

# Conductors

## Skin Effect on Alternative Current (AC)

Skin effect is the tendency of an alternating electric current (AC) to become distributed within a conductor such that the current density is largest near the surface of the conductor and decreases with greater depths in the conductor.

The skin effect is due to opposing eddy currents induced by the changing magnetic field resulting from the alternating current. At 50 Hz, the skin depth is about 9.35 mm (for a round conductor).

The nVent FleXbus and its rectangular geometry do not have these limitations and have a low skin effect ratio. Skin effect is a phenomenon that has the effect of concentrating the

current on the perimeter of the conductor. Its importance depends on frequency, the resistance of the material and the shape/geometry of the conductor.

The ratio of width/thickness for FleXbus is greater than cables and allows for having a good skin effect.

For the same cross section area, FleXbus has a greater surface area for cooling in addition to having a better uniform current density.

For these reasons, FleXbus Conductor manufactured with copper-plated aluminum has the best compromise between cross section, conductivity and weight.

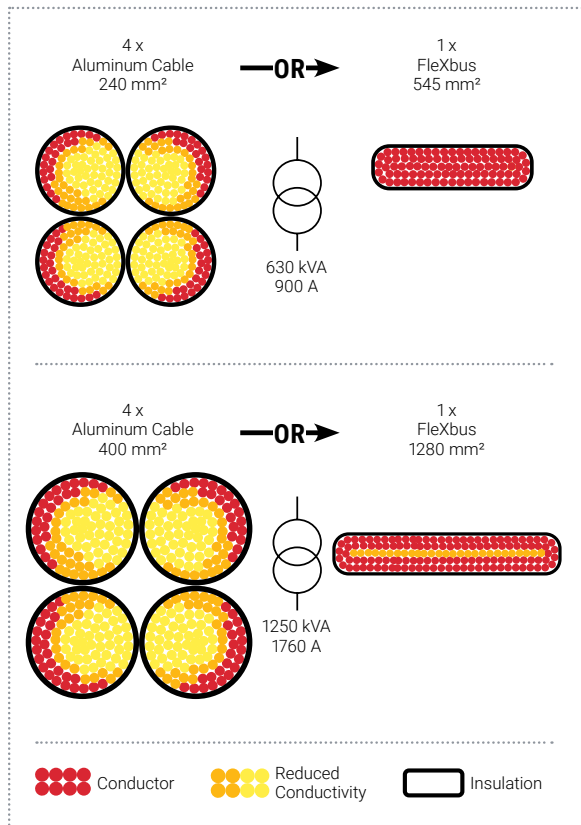

FleXbus Conductor vs. aluminum cable, according to IEC 60364. Around 20% cross-section reduction.

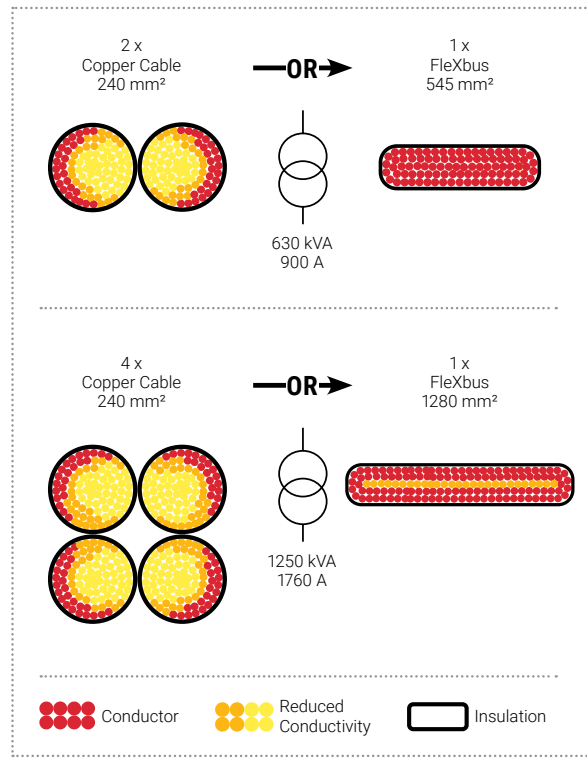

FleXbus Conductor vs. copper cables, according to IEC 60364

# Conductors

## Skin Effect and Frequency

### SKIN EFFECT INCREASES ALONG WITH FREQUENCY

The current ratings of nVent ERIFLEX FleXbus as published in our catalog and website are based on an operating frequency up to 50/60 Hz. Due to all conductors having higher impedance at higher frequencies, a derating factor should be applied for a particular application operated at

higher frequencies. However, the rectangular cross-section of FleXbus reduces this effect as compared to cables with a round cross-section.

An ampacity derating needs to be applied for frequencies higher than 60 Hz. Please refer to the table below:

FleXbus Conductor Type	Cross Section (mm <sup>2</sup> )	Derating Coefficient (K)								
		Frequency (Hz)								
		DC Current and up to 60 Hz	100 Hz	500 Hz	1000 Hz	2000 Hz	4000 Hz	6000 Hz	8000 Hz	10 000 Hz
FLEXCOND220	220	1.0	1.0	1.0	1.1	1.3	1.5	1.7	1.8	1.9
FLEXCOND360	360	1.0	1.0	1.2	1.4	1.7	2.0	2.2	2.3	2.5
FLEXCOND545	545	1.0	1.0	1.4	1.7	2.0	2.4	2.7	2.9	3.0
FLEXCOND640	640	1.0	1.0	1.6	1.8	2.2	2.6	2.9	3.1	3.3
FLEXCOND960	960	1.0	1.1	1.6	1.9	2.2	2.6	2.9	3.2	3.3
FLEXCOND1280	1280	1.0	1.1	1.6	1.9	2.3	2.7	3.0	3.3	3.4
FLEXCOND1810	1810	1.0	1.3	1.9	2.3	2.8	3.3	3.6	3.9	4.1

The formula below specifies how the derating factors on the table should be used:

$$I_f \cong \frac{I_{50Hz}}{K_f}$$



# Conductors

## Thermal Dissipation

Joule heating, also known as ohmic heating and resistive heating, is the process by which the passage of an electric current through a conductor produces heat.

The table below provides the thermal dissipation generated by nVent ERIFLEX Flexbus at Typical Application current rating with conductor temperature at 90°C. The values in the table are in Watt per phase and per available length.

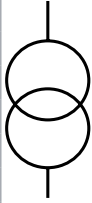
Transformer Power	Transformer LV Current In (A) at 410 V at Secondary	Typical Downstream Circuit Breaker Current rating (A)	Flexbus Conductor/Phase	Thermal Dissipation at Typical Downstream Circuit Breaker Current Rating (W/phase) @ 90°C											
				Flexbus Conductor Length (m)											
				2	3	4	5	6	7	8	9	10	15	25	
	400 kVA	560	500	1x220 mm <sup>2</sup> █	81	121	162	202	243	283	324	364	405	607	1012
	500 kVA	704	630	1x360 mm <sup>2</sup> █	79	118	157	196	236	275	314	353	393	589	982
	630 kVA	900	800	1x545 mm <sup>2</sup> █	84	125	167	209	251	293	335	376	418	627	1046
	800 kVA	1120	1000	1x640 mm <sup>2</sup> █	111	167	223	278	334	390	445	501	557	835	1391
	1000 kVA	1400	1250	1x960 mm <sup>2</sup> █	116	174	232	290	348	406	464	522	580	870	1449
	1250 kVA	1760	1600	1x1280 mm <sup>2</sup> █	142	214	285	356	427	499	570	641	712	1069	
	1600 kVA	2253	2000	1x1810 mm <sup>2</sup> █	157	236	315	394	472	551	630	708	787	1181	
	2000 kVA	2816	2500	2x960 mm <sup>2</sup> ███	232	348	464	580	696	812	928	1044	1159	1739	2899
	2500 kVA	3520	3000	2x1280 mm <sup>2</sup> ███	250	376	501	626	751	877	1002	1127	1252	1878	
	3150 kVA	4435	4000	2x1810 mm <sup>2</sup> ███	315	472	630	787	945	1102	1259	1417	1574	2361	
	3600 kVA	5069	5000	3x1280 mm <sup>2</sup> ████	464	696	928	1159	1391	1623	1855	2087	2319	3478	
	4500 kVA	6336	6300	3x1810 mm <sup>2</sup> ████	521	781	1041	1302	1562	1822	2083	2343	2603	3905	

If Flexbus is not used at a typical application current rating but within higher or lower value, see the graphics on the next page:



[nVent.com/ERIFLEX](http://nVent.com/ERIFLEX) | 49

# Conductors

## Thermal Dissipation

One FleXbus Conductor Per Phase THERMAL DISSIPATION (W/m)

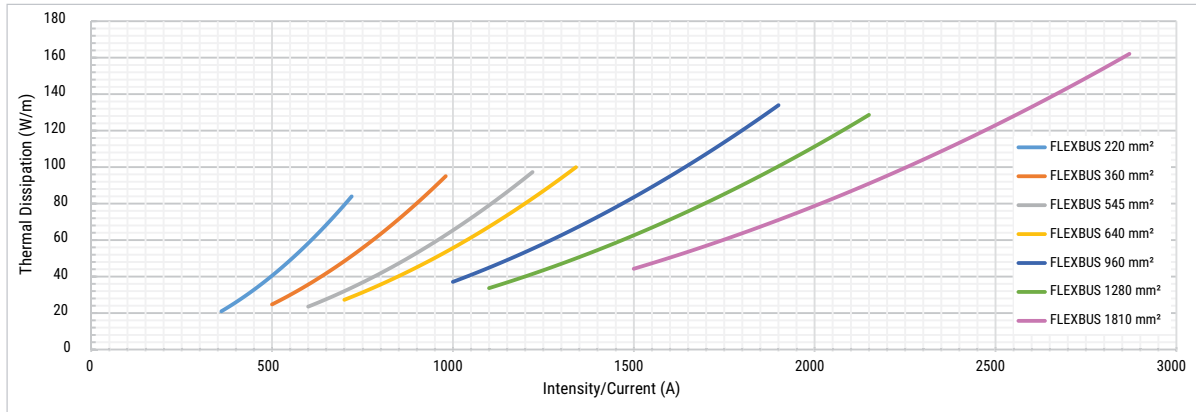

Two FleXbus Conductors Per Phase THERMAL DISSIPATION (W/m)

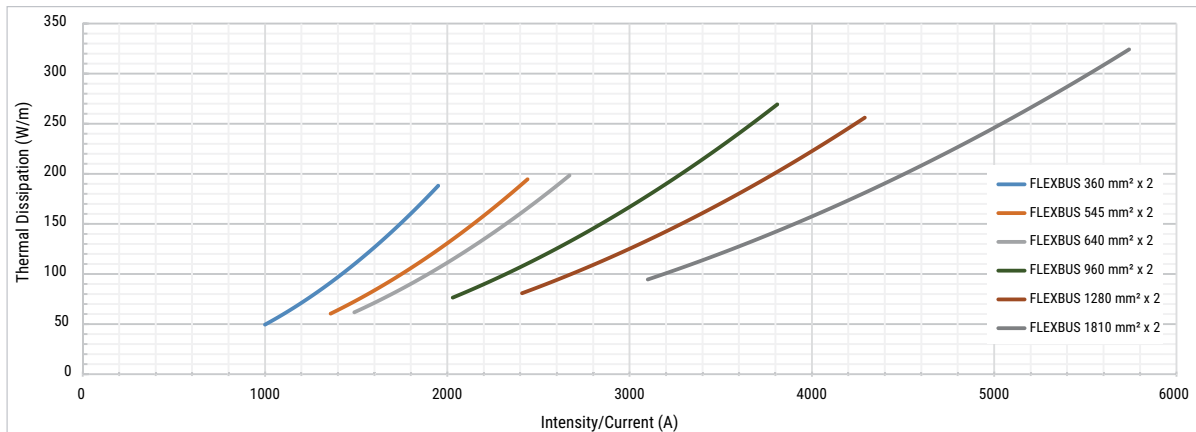

Three FleXbus Conductors Per Phase THERMAL DISSIPATION (W/m)

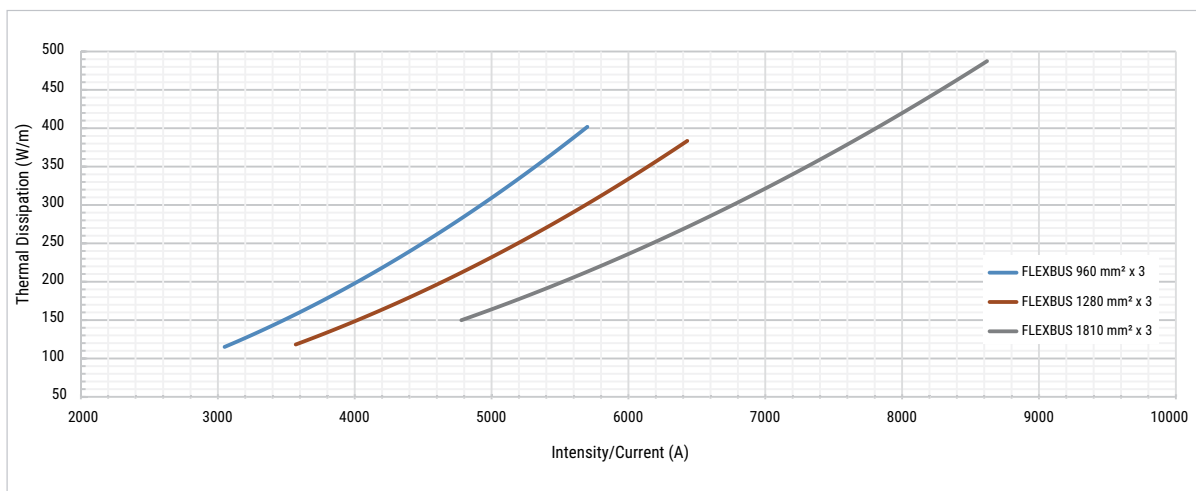

# Conductors

## Short-Circuit – Insulation Thermal Resistance

**A Thermal Phenomenon (Icw)** is created by the ampacity carried in the conductive parts. The increase of conductor temperature is linked to the resistance of the conductor material and cross section, ampacity and duration.

This phenomenon may destroy the device or the conductor insulation if the selection is not properly done. The device or conductor characteristics are quantified by a maximum admissible ampacity (Icw).

Flexbus Conductor Type	Cross Section (mm <sup>2</sup> )		Thermal Short-Circuit Strength (Icw)			
			kA (0.2 second)	kA (0.5 second)	kA (0.8 second)	kA (1 second)
FLEXCOND220	1x220 mm <sup>2</sup>	□	32.5	20.5	16.2	14.5
FLEXCOND360	1x360 mm <sup>2</sup>	□	45.9	29.0	22.9	20.5
FLEXCOND545	1x545 mm <sup>2</sup>	□	69.5	43.9	34.7	31.1
FLEXCOND640	1x640 mm <sup>2</sup>	□	81.6	51.6	40.8	36.5
FLEXCOND960	1x960 mm <sup>2</sup>	□	122.4	77.4	61.2	54.7
FLEXCOND1280	1x1280 mm <sup>2</sup>	□	163.1	103.2	81.6	73.0
FLEXCOND1810	1x1810 mm <sup>2</sup>	□	230.7	145.9	115.3	103.2
FLEXCOND220 x2	2x220 mm <sup>2</sup>	□□	56.1	35.5	28.0	25.1
FLEXCOND360 x2	2x360 mm <sup>2</sup>	□□	91.8	58.0	45.9	41.0
FLEXCOND545 x2	2x545 mm <sup>2</sup>	□□	138.9	87.9	69.5	62.1
FLEXCOND640 x2	2x640 mm <sup>2</sup>	□□	163.1	103.2	81.6	73.0
FLEXCOND960 x2	2x960 mm <sup>2</sup>	□□	244.7	154.8	122.4	109.4
FLEXCOND1280 x2	2x1280 mm <sup>2</sup>	□□	326.3	206.4	163.1	145.9
FLEXCOND1810 x2	2x1810 mm <sup>2</sup>	□□	461.4	291.8	230.7	206.3
FLEXCOND960 x3	3x960 mm <sup>2</sup>	□□□	367.1	232.2	183.5	164.2
FLEXCOND1280 x3	3x1280 mm <sup>2</sup>	□□□	489.4	309.5	244.7	218.9
FLEXCOND1810 x3	3x1810 mm <sup>2</sup>	□□□	692.1	437.7	346.0	309.5

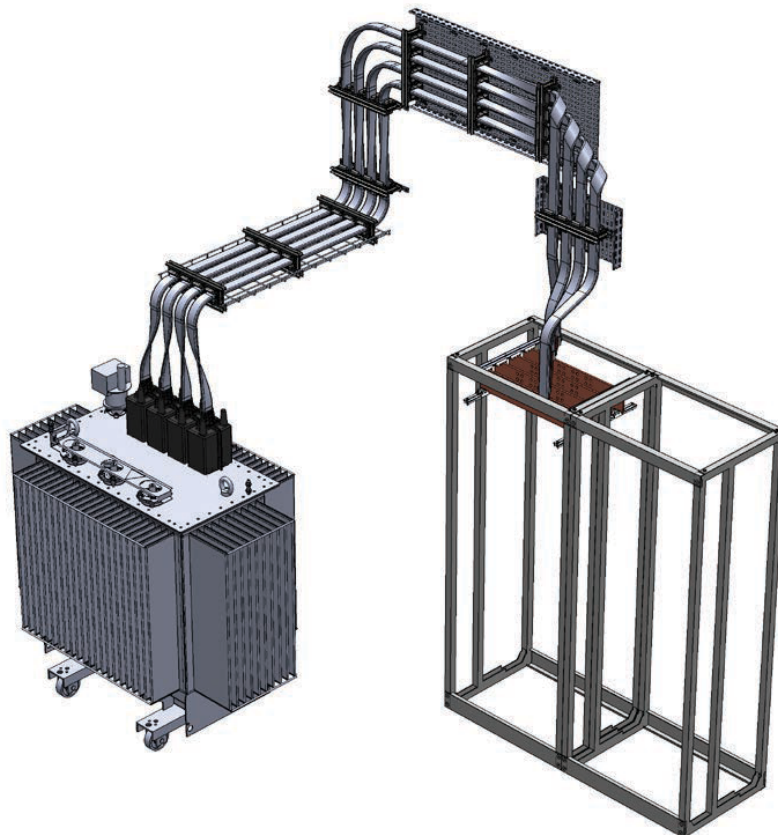

# Conductors

## Flexibility and Bending Radius Comparison With Cable

Bend radius is the minimum radius a pipe, cable, wire, sheet, cable, tube or hose can bend without damaging it.

The minimum bend radius is the radius below which an object should not be bent.

The smaller the radius, the greater the flexibility of the material.

The flexibility of the FleXbus Conductor allows for more design options when comparing to traditional cable conductors. FleXbus is manufactured with multiple 0.2 mm wires and requires less wire-bending space than cable due to high flexibility and has no strict minimum bending radius constraint. It is possible to realize a compact power connection and reduce the size and price of the technical room/substation/shelter where the FleXbus System will be installed. In addition, the FleXbus Conductor flexibility drastically reduces the termination stress.

To determine how tight a given cable can be bent without damage, use the chart below to obtain the multiplier based on cable type. Note that this table is an overview. Cable manufacturer data should be checked.

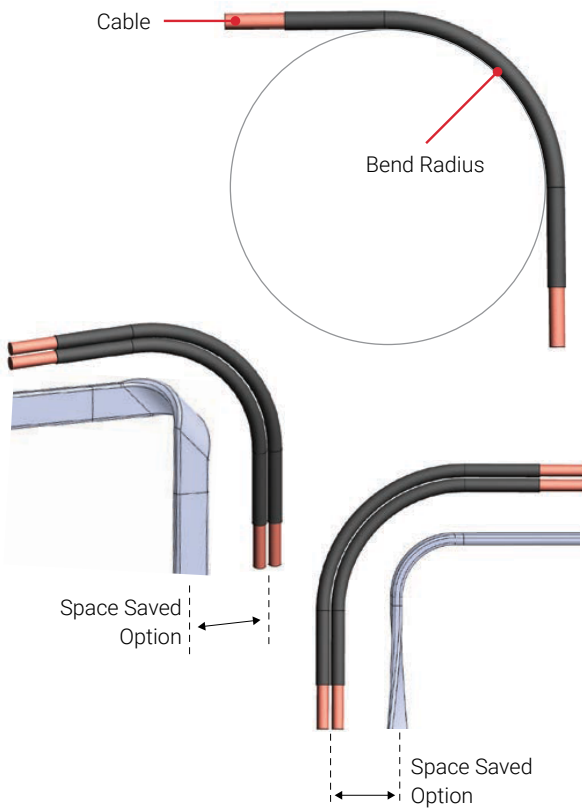

**Standard reference:**

IEC 60364 Low-Voltage Electrical Installations

522.8.3 The radius of every bend in a wiring system shall be such that conductors or cables do not suffer damage and terminations are not stressed.

Type	Minimum Bending Radius
Single or multiple conductor cables – no metallic shielding	8 x the overall cable diameter
Single conductor cable – with metallic shielding	12 x the overall cable diameter
Multiple conductor cables – with individually shielded conductors	12 x the individual cable diameter or 7 x the overall cable diameter (whichever is greater)

Table from NEC Articles 300-34, 334-11 & 336-16, as well as Appendix H of ICEA S-66-524 and ICEA S-68-516

# Conductors

## Class II Insulation (Reinforced Insulation)

The nVent ERIFLEX Flexbus has Class II insulation (reinforced insulation) certification, according to IEC 61439-1 and IEC 60364-4-41 due to:

- High dielectric strength (>20KV/mm)
- High mechanical resistance (IK 09)
- High-temperature resistance/self-extinguishable (Glow Wire Test 960°C)

As per IEC 61439, this certification allows:

- Touching and fixing directly to metal parts (without sharp edges) permitted (no clearance distance needed).
- Max operating current: up to 100% of the conductor maximum rated temperature (80% without Class II).



### Standard reference:

The IEC 60364 Low-Voltage Electrical Installations, part 4-41 (Protection for safety – Protection against electric shock) indicate:

410.3.3 In each part of an installation one or more protective measures shall be applied, taking account of the conditions of external influence: double or reinforced insulation (Clause 412)

412 Protective measure: double or reinforced insulation

412.1.1 Double or reinforced insulation is a protective measure in which:

- Basic and fault protection is provided by reinforced insulation between live parts and accessible parts.

NOTE: This protective measure is intended to prevent the appearance of dangerous voltage on the accessible parts of electrical equipment through a fault in the basic insulation.

412.1.2 The protective measure by double or reinforced insulation is applicable in all situations, unless some limitations are given in the corresponding Part 7 of IEC 60364.

412.2.1.1 Electrical equipment shall be of the following types, and type tested and marked to the relevant standards:

- Electrical equipment having double or reinforced insulation (Class II equipment);
- Electrical equipment declared in the relevant product standard as equivalent to Class II, such as assemblies of electrical equipment having total insulation (see IEC 61439-1).

**Class II conductor should be used.**

**Flexbus Conductor has Class II insulation certification**, according to IEC 60364-4-41, which refers to IEC 61439-1.

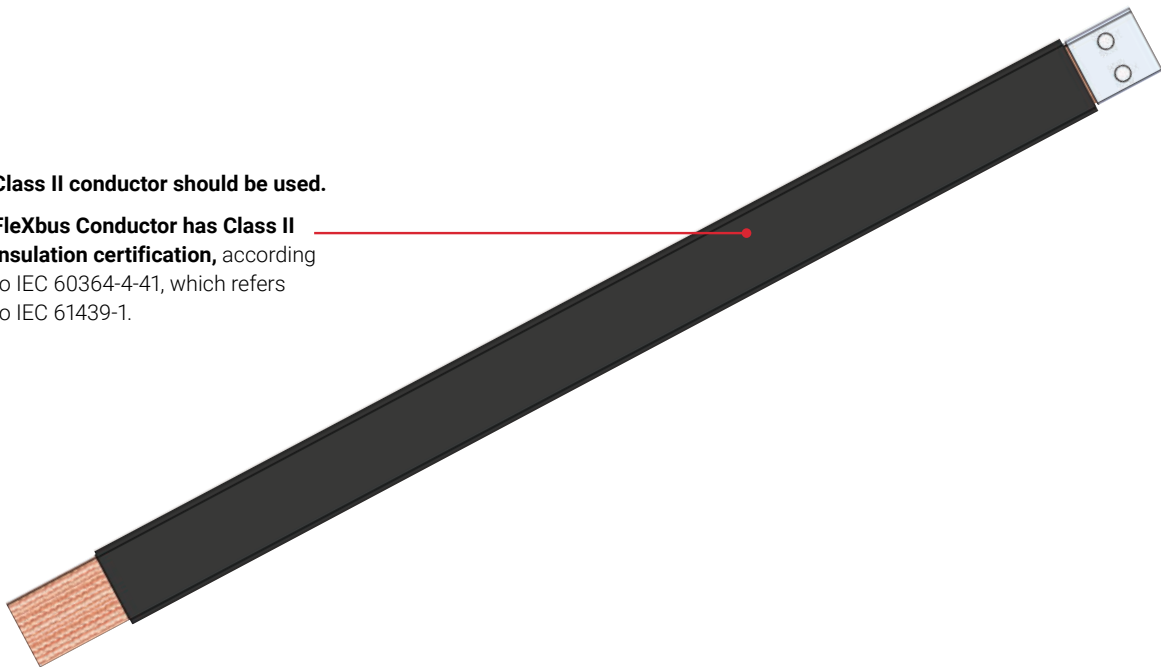

# Conductors

## Class II Insulation (Reinforced Insulation)

TABLE 4 FROM IEC 61439-1 – CONDUCTOR SELECTION AND INSTALLATION REQUIREMENTS (8.6.4)

Type of Conductor	Requirements
Bare conductors or single-core conductors with basic insulation, for example cables according to IEC 60227-3	Mutual contact or contact with conductive parts shall be avoided, for example by use of spacers
Single-core conductors with basic insulation and a maximum permissible conductor operating temperature of at least 90°C, for example cables according to IEC 60245-3, or heat-resistant thermoplastic (PVC) insulated cables according to IEC 60227-3	Mutual contact or contact with conductive parts is permitted where there is no applied external pressure. Contact with sharp edges shall be avoided. These conductors may only be loaded such that an operating temperature of 80% of the maximum permissible conductor operating temperature is not exceeded
Conductors with basic insulation, for example cables according to IEC 60227-3, having additional secondary insulation, for example individually covered cables with shrink sleeving or individually run cables in plastic conduits	No additional requirements
Conductors insulated with a very high mechanical strength material, for example Ethylene Tetrafluoro Ethylene (ETFE) insulation, or double-insulated conductors with an enhanced outer sheath rated for use up to 3 kV, for example cables according to IEC 60502	
Single- or multi-core sheathed cables, for example cables according to IEC 60245-4 or IEC 60227-4	

If a conductor with basic insulation (not Class II compliant insulation) is used, additional requirements are mandatory.

Flexbus Conductors use Class II insulation and do not have any additional requirements according to the standard.

The advantage of using a reinforced/double-insulated conductor is that Table 4 requires “no additional requirement”:

### BARE CONDUCTOR:

- Clearance distance and supports/insulators.

Example: solid bars.

### BASIC INSULATION CONDUCTOR:

- No contact or fixing directly to any metal parts.
- Operating temperature 80% of the maximum allowed by the conductor to prevent thermal short-circuit damages.

Example: conductors with shrinkable sleeve, one single-core cable.

### CLASS II CONDUCTOR:

- Touching and fixing directly to metal parts permitted (no clearance distance needed).
- 100% max operating temperature (115°C for Flexbus).

If any conductors do not fulfill the requirements, the circuit is subject to additional short-circuit tests (10.11).

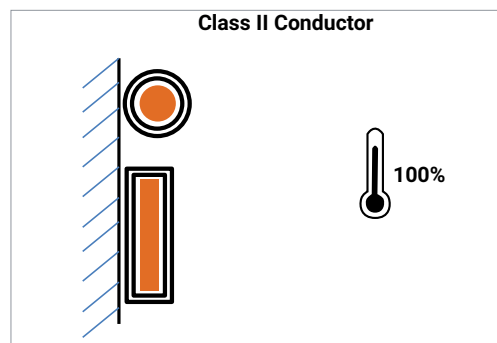
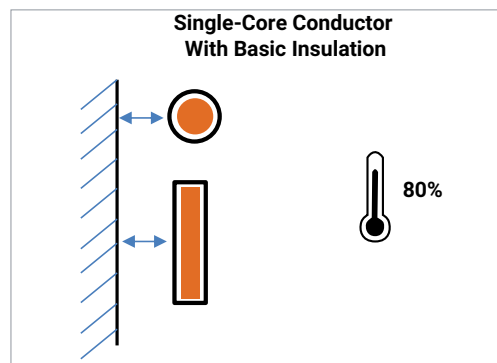

# Conductors

## Altitude Effect

For conductors to be used at altitudes exceeding 2000 m, it's necessary to take the reduction of the dielectric strength and the cooling capacity affected by the air density into account. The air-cooling capability drops along with the altitude increasing, meaning a derating factor should be used as the altitude exceeds 2000 m.

The table below abstracted from DIN 43671 may be used as a reference for FleXbus.

Altitude (m)	Derating Factor	
	Ampacities (A)	Voltage (V)
> 2000	0.99	0.99
> 3000	0.96	0.96
> 4000	0.9	0.8

## Low Smoke (LS)



### LOW-SMOKE (LS) MATERIAL OFFERS:

- Improved visibility conditions in case of fire due to lower density of smoke.
- Ability to easily locate the emergency exit.
- Rescue workers the ability to assess an emergency situation.
- Less damage to electrical equipment.

### LOW-SMOKE (LS) FLEXBUS IS TESTED AND COMPLIES WITH:

- IEC® 61034-2 (Measurement of smoke density of cables burning under defined conditions).
- IEC® 60695-6-2 (Fire hazard testing – Part 6-2: Smoke obscuration – Summary and relevance of test methods).
- ISO 5659-2 (Determination of the optical density of smoke produced from a horizontally positioned test specimen subjected to a specific thermal radiation in a sealed chamber).
- UL® 2885 (Outline of Investigation for Acid Gas, Acidity and Conductivity of Combusted Materials).

FleXbus is a low-smoke conductor.



# Conductors

## Halogen-Free (HF)



### HALOGEN-FREE (HF) MATERIAL DOES NOT CONTAIN:

- Fluorine
- Chlorine => (used for PVC)
- Bromine
- Iodine
- Astatine

### HALOGEN-FREE (HF) MATERIAL OFFERS:

- Better environmental impact
- Reduction in the quantity of toxic smoke for people
- Reduction of corrosive smoke from electrical equipment

### HALOGEN-FREE (HF) FLEXBUS IS TESTED AND COMPLIES WITH:

- IEC® 60754-1 (Test on gases evolved during combustion of materials from cables – Part 1: Determination of the halogen acid gas content).
- IEC® 62821-2 (Electric cables – Halogen-free, low smoke, thermoplastic insulated and sheathed cables of rated voltages up to and including 450/750 V).
- UL® 2885 (Outline of Investigation for Acid Gas, Acidity and Conductivity of Combusted Materials).

FleXbus is a halogen-free conductor.

## Flame Retardant (FR)



Flame-retardant (FR) material, also called self-extinguishing material, has the effect of slowing down the spread of fire according to international standards such as:

- UL 94 V-0
- IEC 60695-2 (Glow Wire Test 960°C)

FleXbus has a flammability rating of UL 94 V-0.

In addition, FleXbus passed IEC 60695-2 (Glow Wire Test) at the highest possible level (960°C) with burning or glow time ≤ 30 seconds and with the paper and wood undamaged during the test sequence.

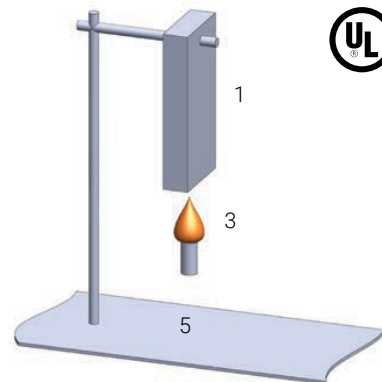
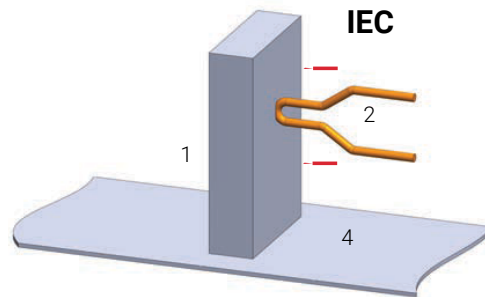

1. Specimen
2. Glow wire
3. Flame
4. Tissue
5. Cotton



# Conductors

## The European CPR Cable Regulations



### INTRODUCTION

Cable manufacturers and suppliers are required to meet specific classifications for the products they sell around the world, and label them as such for their customers.

Under the European **Construction Products Regulation** (CPR), all cable manufacturers and suppliers are now required to apply CE marking to all cables permanently installed in all household, commercial or industrial buildings or civil engineering work in the European Union. The standard for cables, EN 50575, defines the test standards for testing the "Reaction to Fire" performance of a cable and also the method of classifying this performance.

This new set of regulations applies to power, communications and fiber-optic cables no matter where they are being manufactured.

The main objective of the CPR is to increase safety in buildings and ensure the health protection of individuals. The regulation is intended to help with the comparison of different products so that the most suitable product can be selected for specific installation projects.

The Euroclass Table defines seven classes (**Aca**, **B1ca**, **B2ca**, **Cca**, **Dca**, **Eca** and **Fca**) based on their fire reaction, such as heat release and flame spread/propagation.

In this classification, heat release and flame spread/propagation are the main classification criteria, but a series of additional criteria is also defined. Those additional criteria apply only to classes B1ca, B2ca, Cca and Dca and they regard:

- s: smoke production from s1a (visibility better than 80%) to s3 (very low visibility).
- d: flaming droplets from d0 (no flaming droplets) to d2 (no requirements).
- a: acidity of emissions from a1 (very low corrosivity) to a3 (no requirements).

The additional criteria «smoke» and «acidity» focus on the quality of emissions during fire that are critical for a safe escape.

Cable Types	Euroclass	Criteria	Additional Criteria
No contribution to fire	<b>Aca</b>	Non combustible	
For future developments	<b>B1ca</b>	Very low propagation	
Low-fire-hazard cables	<b>B2ca</b>	Very low fire propagation Very low heat release Low flame propagation	Smoke production (s1, s1a, s1b, s2, s3) Acidity (a1, a2, a3) Flaming droplets (d0, d1, d2)
	<b>Cca</b>	Low fire propagation Low heat release Low flame propagation	
Standard cables	<b>Dca</b>	Moderate heat release Low flame propagation	
	<b>Eca</b>	Low flame propagation (only)	
	<b>Fca</b>	Don't even meet the requirement of Class Eca	

The Flexbus Conductor are classified as **Eca** - s2, d2, a3 as per our internal CPR evaluation.

# Conductors

## EN 45545-2 Fire Testing to Railway Components

### EN 45545-2 EUROPEAN UNION STANDARD FIRE TESTING TO RAILWAY COMPONENTS

In order to choose the appropriate product for a given application, it is the customer's responsibility to understand the extent of use for the product, as well as the intended final use for the Rolling Stock. Vehicles are classified as: HL1, HL2 or HL3 depending on their time in tunnels and whether they contain sleeper cars. The HL1 classification represents the lowest Hazard Level and HL3 represents the highest. Please refer to EN 45545-2 for further definitions.

This standard provides guidance to quantify the impact of a fire compared with the product requirements classification.

nVent ERIFLEX Flexbus would fall under the R22 and R23 product requirement sets, depending on their installation location.

There are three tests used to establish product performance versus these product requirements:

- Oxygen index to T01 EN ISO 4589-2
- Flue gas density to T 10.03 EN ISO 5659
- Oxygen index to T 12 NF X70-100-1 and -2

Performance requirements on EN 45545-2 for each of these tests are summarized below. Please refer to EN 45545-2 for additional details.

				HL1	HL2	HL3
R22	T01 EN ISO 4589-2 OI	Oxygen Content %	Minimum	28	28	32
	T10.03 EN ISO 5659-2: 25 kWm	Ds max. dimensionless	Maximum	600	300	150
	T12 NF X70-100-1: and -2, 600°C	CItnlp dimensionless	Maximum	1.2	0.9	0.75
R23	T01 EN ISO 4589-2: OI	Oxygen Content %	Minimum	28	28	32
	T10.03 EN ISO 5659-2: 25 kWm <sup>2</sup>	Ds max. dimensionless	Maximum	-	600	300
	T12 NF X70-100-1 and -2, 600°C	CItnlp dimensionless	Maximum	-	1.8	1.5

nVent ERIFLEX Flexbus conforms to EN 45545, obtaining an HL3 classification for chapters R22 and R23.

### EN 50264-3-1 VOLTAGE REQUIREMENT FOR RAILWAY APPLICATIONS

Our advanced insulation technology used in **Flexbus Advanced** has been tested according to the **EN 50264-3-1 standard for voltage requirements**.

This standard is specific for **Railway applications**: (trains, locomotives, trolley-busses, etc.), switching stations and control panels.

Standard title (EN 50264-3-1): Railway applications. Railway rolling stock power and control cables having special fire performance. Cables with crosslinked elastomeric insulation with reduced dimensions. Single core cables

**nVent ERIFLEX Flexbus meets the requirements of tests 7.3, 7.5, 7.6 and 7.7 from EN50264-3-1 for voltages up to 6 kV AC/DC**



# Conductors

## How to Achieve a Good Electrical Connection

### CONTACT SURFACE CONDITIONS

The surface must be clean and flat but not polished. It must be oxide- and grease-free.

### CLAMPING TORQUE AND HARDWARE ON RIGID COPPER BARS AND TRANSFORMER PALMS

Use a Class 8.8 Zn 8C zinc-plated bolt and "contact" and "flat" washers tightened with a torque wrench, without lubrication.

- Class 8.8 Zn 8C or SAE Grade 5 hardware can be used except where otherwise designated by the designer of the pieces installed.
- Contact and flat washers provide resistance to vibration.

## Contact Kits

Part Number	Global Part Number	Description	Thread Size	Thread Length	Torque	Packing Unit
558310	CONT-KIT-M6X16	Contact Kit M6 x 16	M6	16 mm	13 N-m	100 pc
558340	CONT-KIT-M8X30	Contact Kit M8 x 30	M8	30 mm	30 N-m	100 pc
558370	CONT-KIT-M10X30	Contact Kit M10 x 30	M10	30 mm	60 N-m	100 pc
558410	CONT-KIT-M10X50	Contact Kit M10 x 50	M10	50 mm	60 N-m	100 pc
558440	CONT-KIT-M12X30	Contact Kit M12 x 30	M12	30 mm	110 N-m	100 pc
558460	CONT-KIT-M12X40	Contact Kit M12 x 40	M12	40 mm	110 N-m	100 pc
558480	CONT-KIT-M12X50	Contact Kit M12 x 50	M12	50 mm	110 N-m	100 pc
567880	CONTKITM12X60ZB	Contact Kit M12 x 60	M12	60 mm	110 N-m	100 pc
558490	CONT-KIT-M12X80	Contact Kit M12 x 80	M12	80 mm	110 N-m	100 pc

Kit includes 100 bolts, 100 nuts, 200 flat washers and 200 contact washers.

**Material:** Steel

**Finish:** Electrogalvanized

**Quality Class:** 8.8

**Coating Class:** Zn 8C

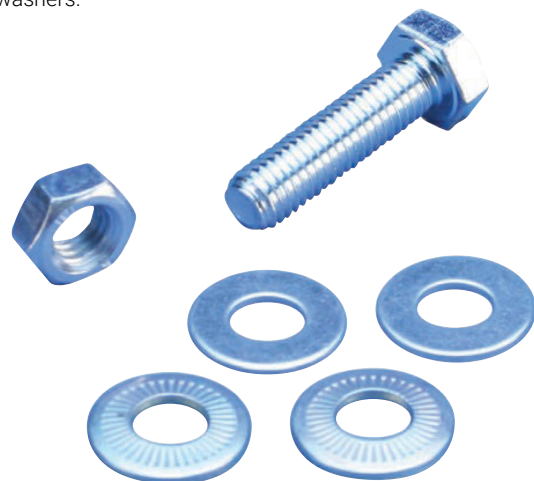

# Conductors

## Contact Kits

Metric (With Contact Washer)							
Bolt Size Ø	M6	M8		M10	M12	M14	M16
F (daN)	800	1450		2300	3700	4400	6000
Clamping Torque (Nm)	13	30		60	110	174	274
Imperial (With Contact Washer)							
Bolt Size Ø	¼ - 20	⅝ - 18	¾ - 16	7/16 - 14	½ - 13	9/16 - 12	⅝ - 11
Clamping Torque (Foot-Pounds)	9	18	31	50	75	110	150

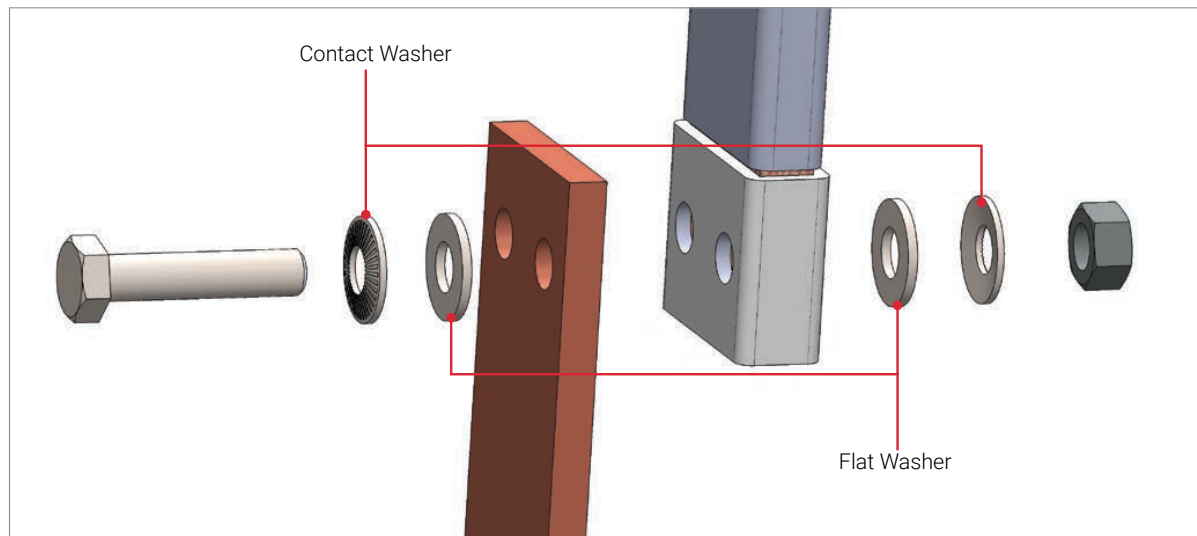

### RECOMMENDED BOLT DIAMETER IN FUNCTION OF THE DRILLED/PUNCHED HOLE DIAMETER

Drilling/Punching diameter depends on the diameter of the bolts and nuts used.

Bolt Diameter (Metric)	Max. Drilling/Punching Diameter (mm)
M6	7
M8	10
M10	12
M12	14

Bolt Diameter (Imperial)	Max. Drilling/Punching Diameter (Inches)
¼ - 20	⅝"
⅝ - 18	¾"
¾ - 16	7/16"
7/16 - 14	½"
½ - 13	9/16"

# Conductors

## Connection and Distribution on Rigid Copper Bars

If the busbars have several bars per phase, the connection points must be distributed over the various bars of the same phase. This can be achieved by using copper plates (Flexbus palm extender) between copper bars or, if possible, the nVent ERIFLEX Flexbus between two copper bars. This installation will guarantee a good repartition of current in the busbar.

See Page 77 for Flexbus Extenders dimensions.



### Standard reference:

The IEC 60364 Low-Voltage Electrical Installations

433.4.2 Unequal current sharing between parallel conductors.

Note: Currents in parallel conductors are considered to be unequal if the difference between any currents is more than 10% of the design current for each conductor.

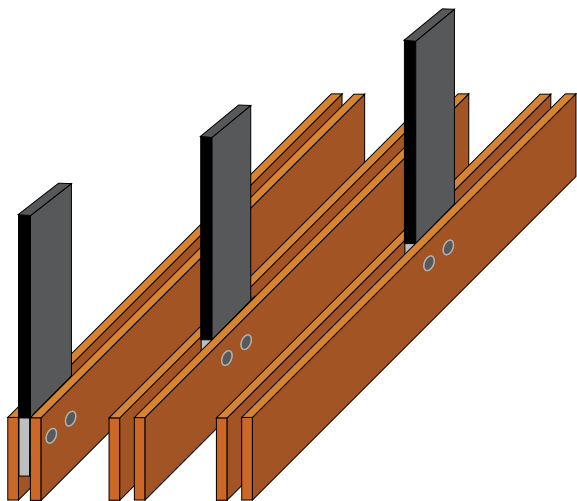

Two busbars per phase and one Flexbus Conductor directly connected.

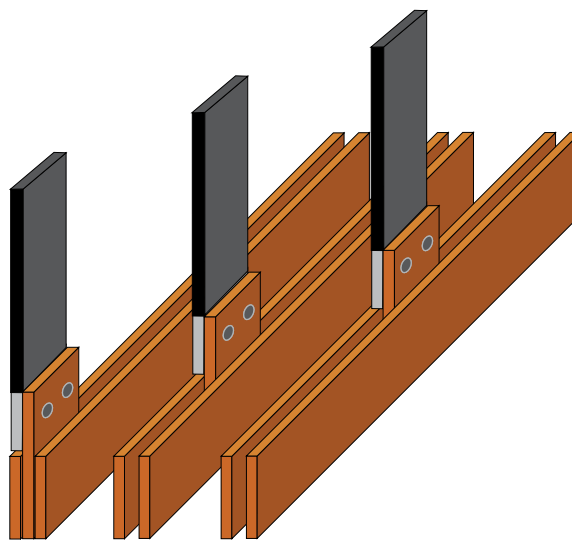

Two busbars per phase and one Flexbus Conductor connected through palm extender.

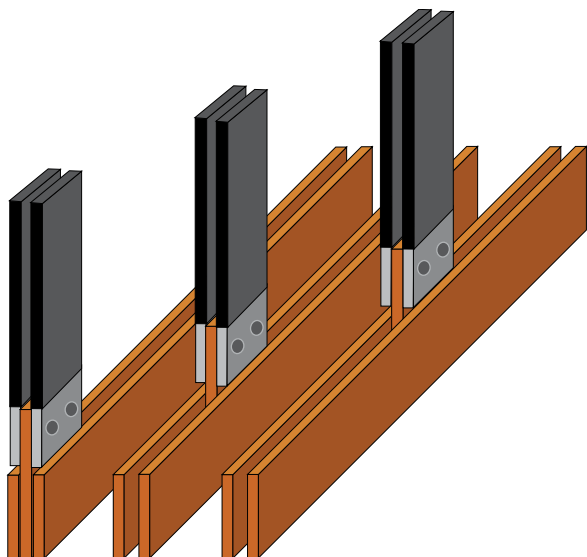

Two busbars per phase and two Flexbus Conductors connected through palm extender.

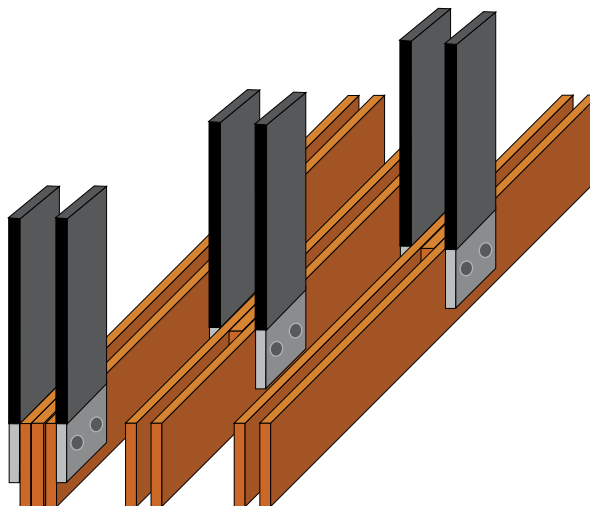

Two busbars per phase and two Flexbus Conductors directly connected and spacer between copper bars.

**Note:** The minimum clearance distance is 14 mm according to IEC 61439-1 with air pollution degree 3. The clearance distance is the shortest distance in free air between two live parts.

nVent.com/ERIFLEX | 61

# Conductors

## Connection to an Electrical Device

### **FLEXBUS CONNECTED TO AN ACTIVE ELECTRICAL DEVICE**

- Use the basic hardware delivered with the device and add a flat washer if not provided.
- Apply the tightening torque specified in the electrical device manual.

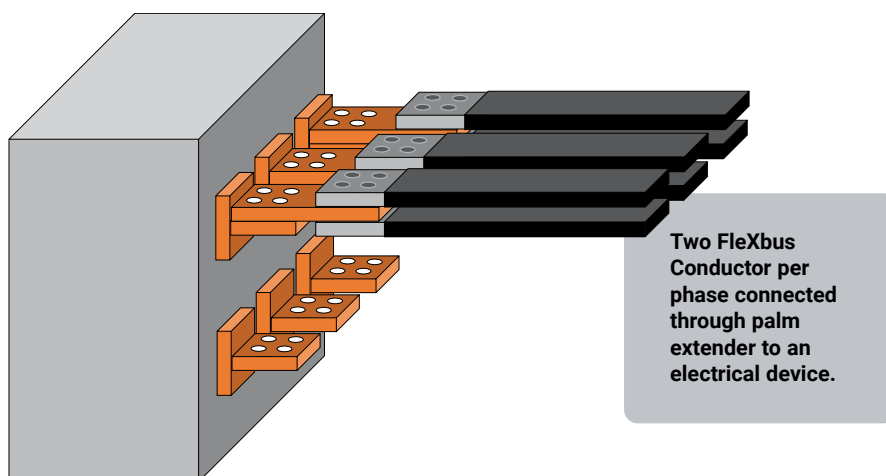
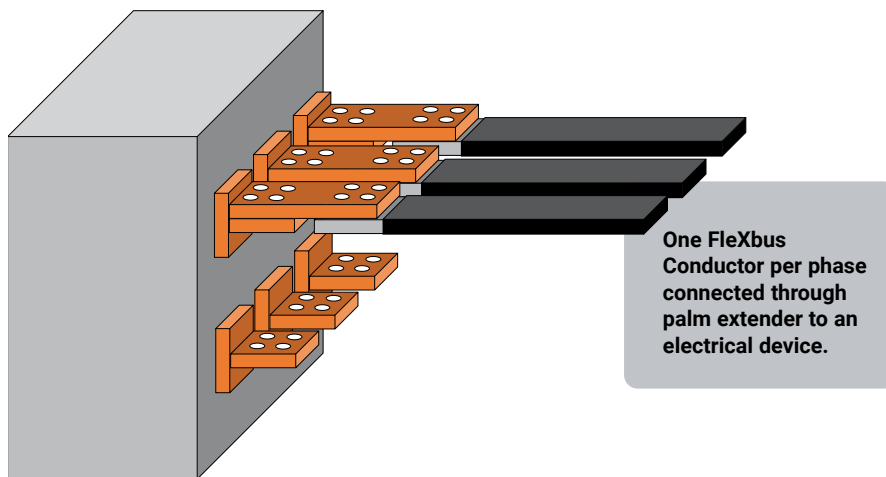
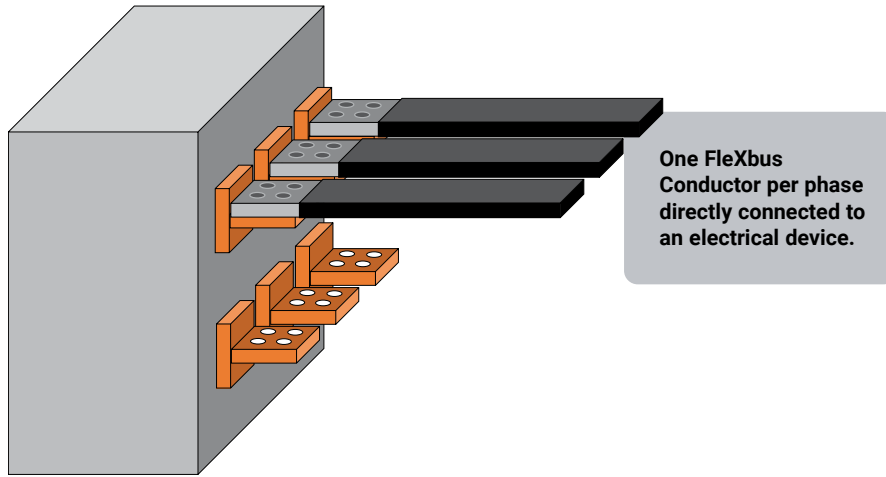

# Conductors

## Voltage Drop

The impedance of circuit conductors is low but not negligible: When carrying load current, there is a voltage drop between the origin of the circuit and the load terminals. The correct operation of a load (a motor, lighting circuit, etc.) depends on the voltage at its terminals being maintained at a value

close to its rated value. It is necessary therefore to determine the circuit conductors such that at full-load current, the load terminal voltage is maintained within the limits required for correct performance.



### Standard reference:

The IEC 60364 Low-Voltage Electrical Installations, Annex G

Maximum value of voltage drop

The voltage drop between the origin of an installation and any load point should not be greater than the values in Table G.52.1 expressed with respect to the value of the nominal voltage of the installation

**Table G.52.1 – Voltage drop**

Type of installation	Lighting %	Other uses %
A – Low-Voltage installations supplied directly from a public low-voltage distribution system	3	5
B – Low-Voltage installation supplied from private low-voltage supply <sup>a</sup>	6	8

<sup>a</sup> As far as possible, it is recommended that voltage drop within the final circuits do not exceed those indicated in installation type A.

When the main wiring systems of the installations are longer than 100 m, these voltage drops may be increased by 0.005% per metre of wiring system beyond 100 m, without this supplement being greater than 0.5%.

Voltage drop is determined from the demand by the current-using equipment, applying diversity factors where applicable, or from the values of the design current of the circuits.

Our Flexbus Standard offering is conductors from 2 to 25 meters. The voltage drop is insignificant under those lengths. (< to 1%).

As per the Standard, the voltage drop should not be greater than 3% to 8% in function of the application.

For example, a 360 mm<sup>2</sup> Flexbus Conductor connected into a 500 kVA power supply (704 A) at 410 V Cos  $\phi$  = 0.8 and a

10-meter length will generate a 1.79 V voltage drop (0.44%). Same configuration but with a 50-meter length, will generate an 8.96 V voltage drop (2.19%).

By consequence, Flexbus Conductors used in lengths up to 50 meters is not a concern by voltage drop standard limits.



nVent.com/ERIFLEX | 63

# Conductors

## Harmonics

Harmonic current is generated by most modern electronic loads, which can be found in all sectors of industrial, commercial and domestic facilities. These electronic loads use power electronic devices that are responsible for generating harmonic currents. Common non-linear load examples include:

- Industrial equipment (soldering machines, induction furnaces, bridge rectifiers and battery chargers).
- Variable speed drives (VSDs) with AC or DC motors.
- UPS.
- Information technology equipment (computers, monitors, servers, copiers, printers, etc.).

### APPEARANCE OF A DISTORTED CURRENT WAVEFORM DUE TO HARMONICS

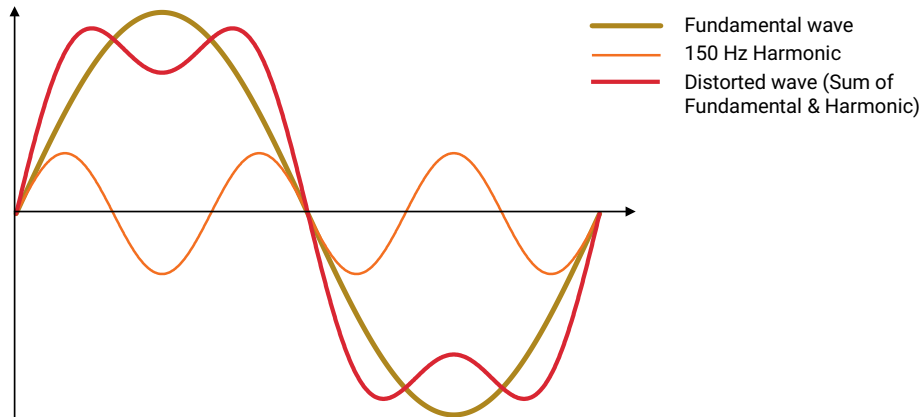

Harmonic currents generated by these loads present some problems, including:

- Voltage distortion – Responsible for failure of some types of electrical equipment.
- Increased losses – The RMS (Root Mean Square) current is higher than the fundamental design current.
- Risk of resonance – When power factor correction capacitors are present.

Third harmonic currents (150/180 Hz) or multiple of 3 (triple-n harmonics) are specifically responsible for increased neutral currents in three-phase, four-wire systems.

Illustration of the overheating risk with standard FlexBus sizing in presence of high level of third harmonics, as shown in the illustrations below.

**ih1: Fundamental frequency (50 Hz)**

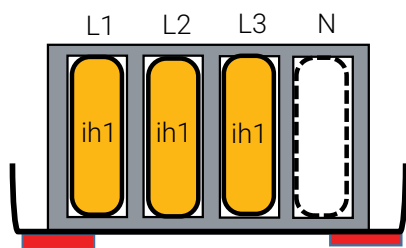

**ih1: Fundamental frequency (50 Hz)**

**ih3: +33% third order harmonics (150 Hz)**

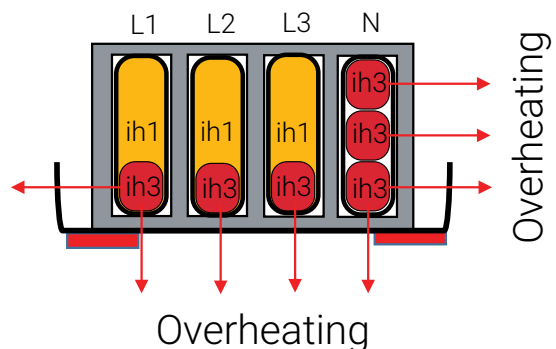



# Conductors

## Harmonics



Standard reference:

The IEC 60364 Low-Voltage Electrical Installations

The reduction factors given in Table E52.1 from IEC 60364 only apply to cables where the neutral conductor is within a four-core or five-core cable and is of the same material and cross-sectional area as the line conductors. These reduction factors have been calculated based on third harmonic currents. If significant, i.e. more than 15 %, higher harmonics, e.g. 9th, 12th, etc. are expected then lower reduction factors are applicable. Where there is an unbalance between phases of more than 50 % then lower reduction factors may be applicable.

Table E.52.1 – Reduction factors for harmonic currents in four-core and five-core cables

Third harmonic content of line current %	Reduction factor	
	Size selection is based on line current	Size selection is based on neutral current
0 – 15	1.0	–
15 – 33	0.86	–
33 – 45	–	0.86
> 45	–	1.0

NOTE: The third harmonic content of the line current is the ratio of the third harmonic and the fundamental (first harmonic), expressed in %.

The most significant harmonic, which does not cancel in the neutral, is usually the third harmonic.

So, according to this table, we can simplify in three possible cases:

- **Third harmonic level below 15% ( $ih3 \leq 15\%$ ):** The neutral conductor is considered as not loaded. The size of the

phase conductors is only dependent on the phase currents (fundamental wave). According to IEC rules, the neutral conductor size may be smaller than the phase conductors, if the cross-section area is higher than 16 mm<sup>2</sup> for copper, or 25 mm<sup>2</sup> for aluminum.

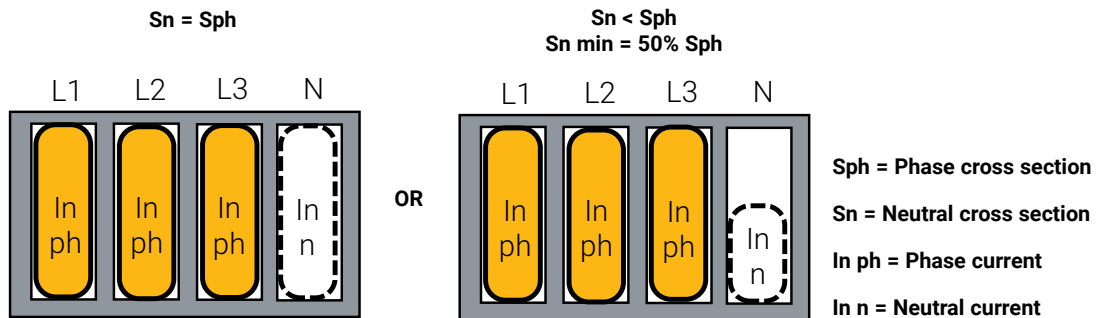

- **Third harmonic level between 15 and 33% ( $15 < ih3 \leq 33\%$ ):** The neutral conductor is considered a current-carrying conductor. The practical current shall be reduced by a factor equal to 86% (or inversely, select a Flexbus Conductor with

a practical current equal to the phase current divided by 0.86. Generally, the calculation shows the upper limit of the Flexbus Conductor cross section. The size of the neutral conductor shall be equal to that of the phases.

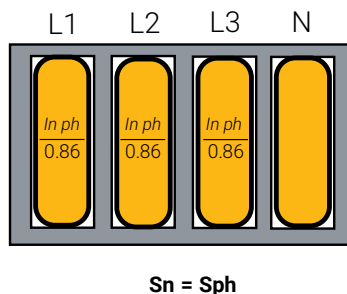

$$\text{Practical current} = \frac{I_{n\ ph}}{0.86}$$

# Conductors

## Harmonics

- **Third harmonic level higher than 33% (ih > 33%)**

The neutral conductor is considered a current-carrying conductor. The recommended approach is to adopt circuit conductors with a neutral conductor larger than the phase

conductors. The neutral current is the primary factor in determining the size of the neutral conductor. Generally, the calculation shows the upper limit of the Flexbus Conductor cross section by a factor of two.

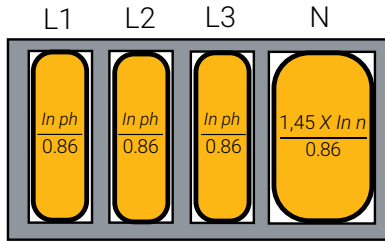

The neutral current is the primary factor.

$$\text{Practical current} = \frac{1.45 \times I_n \text{ n}}{0.86}$$

For other harmonics types (Example: 9th or 12th level), and to select the appropriate Flexbus Conductor cross section, we must not just take into account only the fundamental wave,

but also the other harmonics spectrum by using the formula below for the current:

$$I_{rms} = \sqrt{I_f^2 + I_{3f}^2 + I_{5f}^2 + \dots + I_{nf}^2}$$

With n: Harmonic level

# Conductors

## Precautions Against Magnetic Effects

The passage of high currents in the conductors induces magnetic effects in the surrounding metal masses, which can result in the overheating of materials. In order to minimize the induction created in the magnetic loops, it is always recommended to arrange all active conductors of the same circuit (phase and neutral) in the same metal frames. So, since the vector sum of the currents is zero, the vector sum of the fields created will also be zero.

Usually, Switchboard and power supply enclosure are delivered with nonmagnetic plate for conductors entry. Make sure your individual conductor cut out for conductor entry inside switchboard or power supply enclosure are nonmagnetic (Aluminum, Plastic, Nonmagnetic Stainless steel...)

😊 Nonmagnetic material  
(Aluminum, stainless steel, Plastic...)

🚫 Forbidden: Magnetic material  
(Steel...)

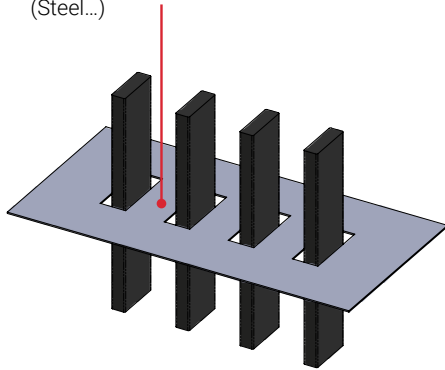

😊 Any material

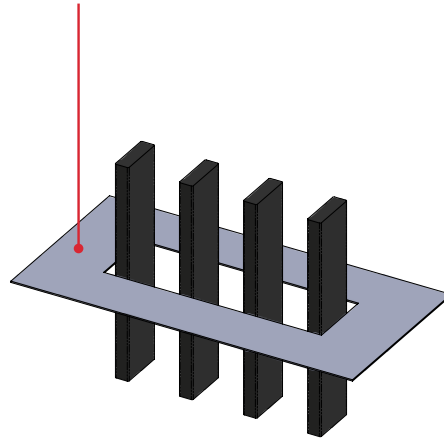

Example of individual cut out on nonmagnetic plate



Example of global cut out on magnetic plate (steel)



# Conductors

## EMC (Electromagnetic Compatibility) Recommendations

It is recommended to electromagnetically separate groups from one another, either using shielding or by installing Flexbus Conductors and other cables in different cableways. The quality of the shielding determines the distance between

groups. If there is no shielding, sufficient distances must be maintained. The distance between power and control cables must be at least five times the thickness of the Flexbus Conductor (100 mm).

### RECOMMENDATION TO INSTALL GROUPS OF FLEXBUS CONDUCTORS AND CABLES IN METALLIC CABLE TRAY

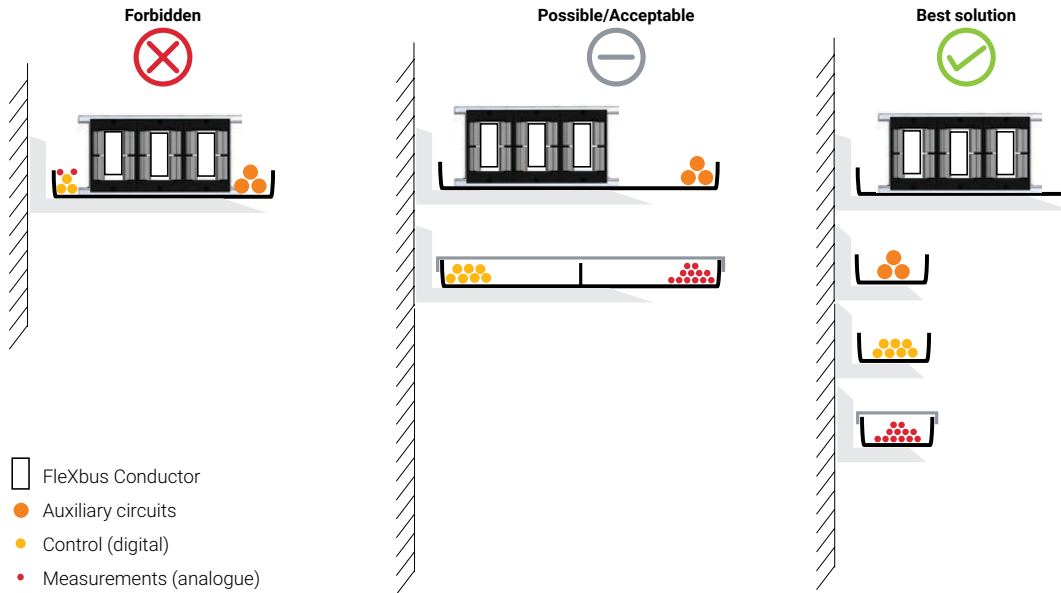

Standard reference:

The IEC 60364 Low-Voltage Electrical Installations, Part 5-52, chapter 528 Proximity of wiring systems to other services.

Both ends of the metal cable tray must always be connected to the local earth network. For very long cable trays, additional connections to the earthing system are recommended between connected devices. All connections to the earthing system should be short.

Metal and non-metal cable trays are available. Metal solutions offer better EMC characteristics. A cableway (cable trays, conduits, cable brackets, etc.) must offer a continuous, conducting metal structure from beginning to end.

For EMC, connections with cables are not efficient; only short and flat conductors are. Their H.F. impedances are 10 times lower than the wire impedances. We recommend using our nVent ERIFLEX MJB Grounding strap.

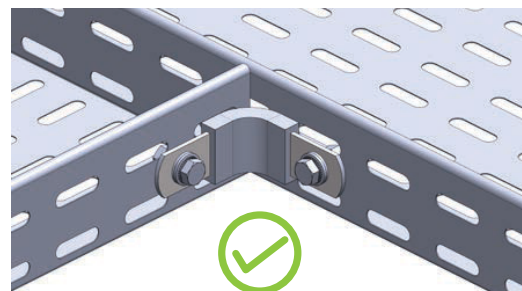
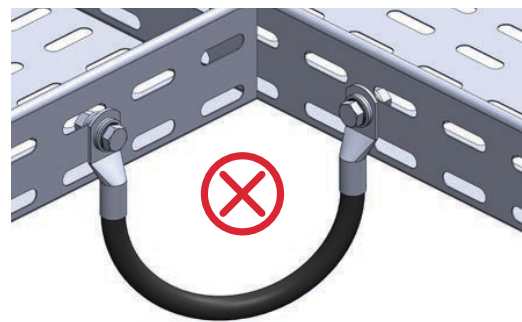

# Conductors

## UV Resistance

FleXbus has been tested according to the AN3 UV radiation level - High UV exposure (IEC 60364-5-52 - Low voltage electric installation, Chapter 522.11: **Solar radiation** (AN).

According to this IEC Standard, AN1 represents low UV exposure, AN2 represents medium UV exposure and AN3 represents High UV exposure.

Tests were performed under the following condition:

- 6 x 168 h exposure
- To pass the test, elongation and tensile strength have to remain within 70% of the original samples.
- Test results showed that samples were not affected by tensile stress during testing.

FleXbus has been tested according to ISO 4892-2 (Plastics – **Methods of exposure to laboratory light sources** – Part 2: Xenon-arc lamps)

Tests were performed under the following conditions:

- 102 min of dry exposure, and 18 min with water spray, repeated for 1000h.
- Test results show that the tensile strength and elongation do remain within 80% of the original values (respectively 5.7% and 10.2%).

Thus, there is no dielectric difference between exposed and non exposed samples.

**Conclusion:** the material is compliant for UV exposure: its mechanical properties (tensile strength and elongation at break) show good retention after 1000h exposure.

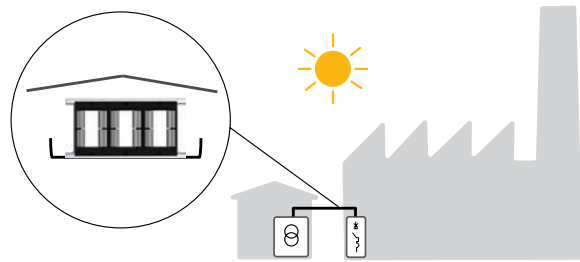

Regarding the electrical properties, there is no variation between the exposed and nonexposed samples.

**Note:** Despite those tests results, we recommend protecting FleXbus Conductors against UV exposure with, for example, a protective cover that do not touch the conductor and allows keeping normal cooling

### Reason:

- Despite the performed tests, the standard does not guarantee product integrity for the entire product life cycle.
- The IEC 60287-1-1 standard (Electric cables - Calculation of the current rating - Part 1-1: Current rating equations (100% load factor) and calculation of losses - General - Chapter 1.4.4: Cables directly exposed to solar radiation) provides a complex derating factor calculation. In this calculation, the coefficient applicable is 0.85. Thus, it is more economical to install a cover rather than applying the 0.85 x In additional derating factor

## Water Resistance

FleXbus insulation has been tested for water resistance. The test sequence includes:

- Internal tests during 10 months with conductor water immersed in 40°C/50°C/60°C/75°C water temperature. Regular resistivity tests – PASS.

FleXbus Conductor is not designed to be a permanent water submerged conductor. However, according to our tests and certification, FleXbus Conductor can be temporarily in contact with water or submerged, for example, in the case of flooding.

It is important that water does not penetrate the inside of the conductor through the ends, between the insulation and the braid. See our IP55 & IP66 conductor entry to protect the termination against dust and water.

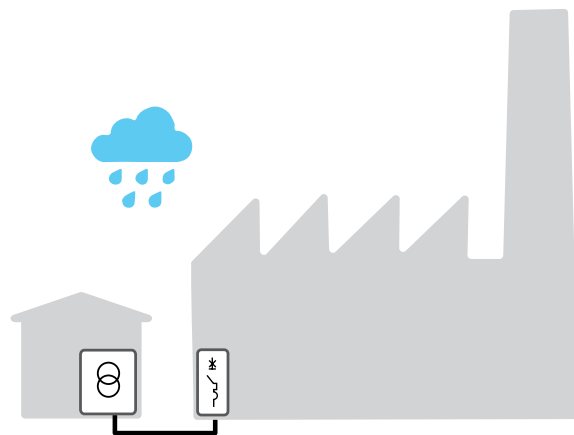

# Conductors

## Vibration Resistance

The level of vibration transmitted to power connection systems is generally quite low in the majority of power distribution installations in buildings. However, it increases in proximity to points of use: machines, traveling cranes, road or rail infrastructure. Onboard applications (ships) are also particularly exposed. Equipment that also generates vibration includes transformers, generators, etc.

Vibration can cause loosening or even cracks or breakages. As recommended by IEC, the usage of flexible conductor is highlighted. This allows rigid systems, like switchboards, to be isolated from equipment that generates vibrations.

Due to the braid flexibility of the FleXbus Conductor, vibrations are fully absorbed.

According to the IEC 60364-5-51 Table 51-A and Annex C, and according to the IEC 60364-5-52 - Chapter 522.7 - Vibration (AH), there are 3 levels of vibration: AH1, AH2 and AH3.

Annex C gives several classes covering these vibration levels.

IEC 60721-4-3 – Annex B – provides test severity sequence details.

The FleXbus System has been tested to vibration level AH2 and **Class 3M6 – High vibration level** on one axe.

The vibration tests carried out are:

- Vibration frequency from 5 Hz to 200 Hz and for 10 cycles
- Acceleration amplitude of 20 m/s<sup>2</sup>. (2g)
- Displacement amplitude of 15 mm total (+7.5 mm / -7.5 mm)

The shock tests carried out are :

- Acceleration amplitude of 250 m/s<sup>2</sup>. (25 g)
- 100 cycles each, positive and negative

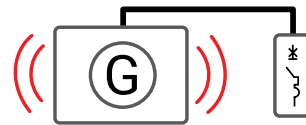

### Standard reference:

The IEC 60364 Low-Voltage Electrical Installations, Chapter 522: Selection and erection of wiring systems in relation to external influences, Part 522.7 Vibration (AH) Special attention should be paid to connections to vibrating equipment. Local measures may be adopted such as **flexible wiring systems**.

## Rodent Protection

For rodent protection, we do not recommend an additional mechanical sleeve around each conductor as this can be difficult to install and can change the technical

characteristics of the conductor. We recommend using chemical protection (like spray) available on the market.



# Conductors

## Product Marking/Identification

Product Brand (nVent ERIFLEX)  
Product Name (Flexbus) = Ready-to-Use LV Power Conductor  
ADVANCED Technology  
(Low-Smoke, Halogen-Free, Flame-Retardant Insulation)

Conductor Cross section (mm<sup>2</sup>)  
Conductor material

Temperature Rating = 115°C (Maximum Continuous Operating Temperature)  
Voltage = 1000 V AC/1500 V DC (Max Voltage Rating)  
Conductor Class = Class II/Reinforced Insulation

European Conformity – According to IEC 61439-1 and IEC 60364

LS = Low-Smoke  
HF = Halogen-Free  
FR = Flame-Retardant  
Quality/Traceability Code

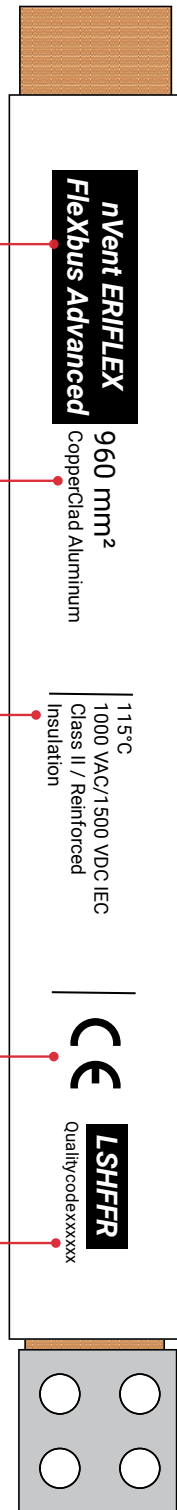

General Information

Technical Data

Other Data

# HCBC Clamp and Plate

## Technical Specifications

### HCBC CLAMP

- To fix the Flexbus Conductor on the transformer/power supply palm, without drilling.
- Rigid design assures even contact pressure.
- Installs quickly and easily.
- Ideal for on-site modifications.
- Made with non-magnetic stainless steel for high current connections between Flexbus Conductor and rigid busbars
- such as transformer terminals (Stainless Steel 304 – EN 1.4301).
- Five versions in function of power supply terminal width: 63/80/100/120/160 mm.
- HCBC Clamp with crimped self-locking nut for vibration resistance and easy installation.
- RoHS compliant.

Part Number	Global Part Number	Description	A (mm)	Transformer Palm Width Min/Max (mm)	B (mm)	C (mm)	D (mm)	Torque	Packing Unit	Weight (Kg)
508190	FLEXCLAMP63	Flexbus HCBC Clamp 63 for power supply palm width 30 to 63 mm	63	30 – 63	123	20	43	100 N-m	1pc	0.53
508191	FLEXCLAMP80	Flexbus HCBC Clamp 80 for power supply palm width 70 to 80 mm	80	70 – 80	140	20	43	100 N-m	1pc	0.84
508192	FLEXCLAMP100	Flexbus HCBC Clamp 100 for power supply palm width 90 to 100 mm	100	90 – 100	160	20	43	100 N-m	1pc	0.92
508193	FLEXCLAMP120	Flexbus HCBC Clamp 120 for power supply palm width 110 to 120 mm	120	110 – 120	180	20	43	100 N-m	1pc	1
508194	FLEXCLAMP160	Flexbus HCBC Clamp 160 for power supply palm width 130 to 160 mm	160	130 – 160	220	20	43	100 N-m	1pc	1.32

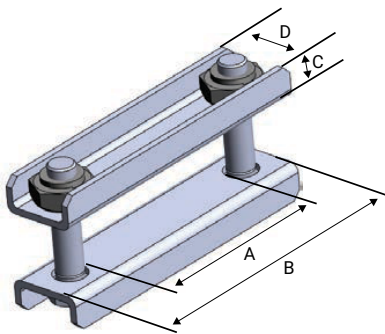

**Note:** It is mandatory to use the HCBC Clamp associated with the HCBC Plate to achieve the proper connection.

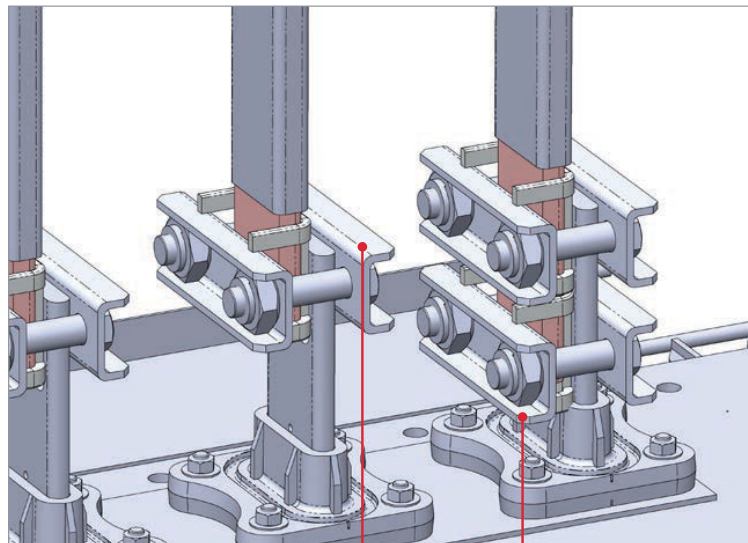
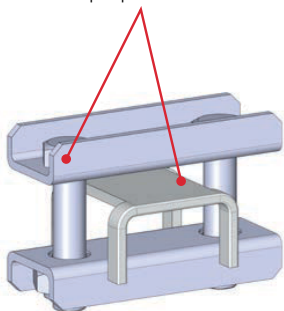

Power supply from 400 to 1250 kVA (Up to 1760 A):  
1 HCBC to install

Power supply from 1600 to 3150 kVA (Up to 4500 A):  
2 HCBCs to install



# HCBC Clamp and Plate

## Technical Specifications

### HCBC PLATE

- HCBC Plate: Rigid tinned copper part to provide a good electrical contact and to maintain braid expansion during compression.
- Installs quickly and easily.
- Made with electrolytic copper Cu-ETP 99.9% purity.
- Tinned copper allows for copper or aluminum conductor connections.
- HCBC Plate: Four versions in function of Flexbus Conductor width: 50 and 100 mm and with or without PE conductor connection.
- HCBC Plate with PE connection allows conductor to be added to interconnect neutral and ground/earth.
- RoHS compliant.

Part Number	Global Part Number	Description	Flexbus Conductor Width A (mm)	B (mm)	C (mm)	D (mm)	E (mm)	HS1 (mm)	HS2 (mm)	Copper Thickness (mm)	Packing Unit	Weight (Kg)
508180	FLEXPLATE50	Flexbus HCBC Plate for conductor 220, 360, 545 and 640 mm <sup>2</sup>	50	63	45	32	-	-	-	5	1pc	0.16
508181	FLEXPLATE100	Flexbus HCBC Plate for conductor 960, 1280 and 1810 mm <sup>2</sup>	100	63	45	41	-	-	-	5	1pc	0.32
508182	FLEXPLATE50PE	Flexbus HCBC Plate for conductor 220, 360, 545 and 640 mm <sup>2</sup> with PE connection	50	100	45	32	70	10.5	14.5	5	1pc	0.49
508183	FLEXPLATE100PE	Flexbus HCBC Plate for conductor 960, 1280 and 1810 mm <sup>2</sup> with PE connection	100	100	45	41	70	12.5	18.5	5	1pc	0.71

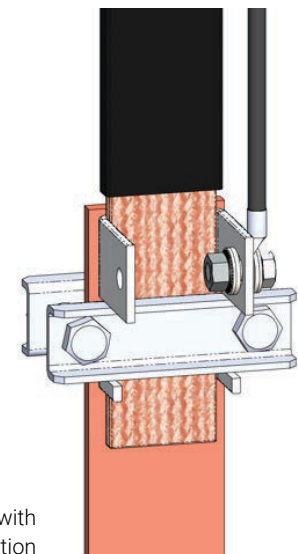
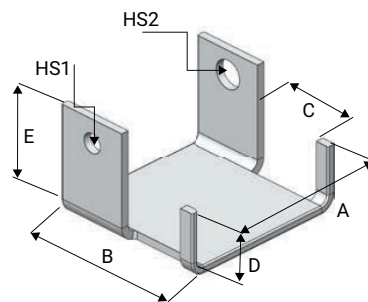
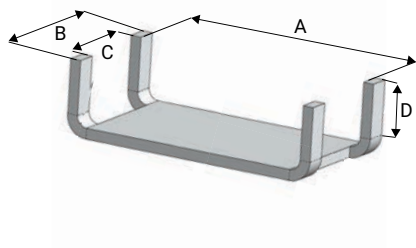

HCBC Plate with PE connection

# HCBC Clamp and Plate

## Mounting

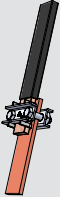
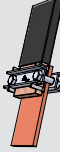
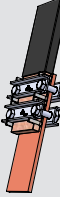
1 FleXbus Conductor per phase		
FleXbus conductor 220, 360, 545 and 640 mm <sup>2</sup>	FleXbus conductor 960 and 1280 mm <sup>2</sup>	FleXbus conductor 1810 mm <sup>2</sup>
1 x HCBC Clamp	1 x HCBC Clamp ≥ 100	2 x HCBC Clamp ≥ 100
1 x HCBC Plate 50	1 x HCBC Plate 100	2 x HCBC Plate 100
		

2 FleXbus Conductors per phase			
FleXbus conductor 220, 360, 545 and 640 mm <sup>2</sup>	FleXbus conductor 220 and 360 mm <sup>2</sup>	FleXbus conductor 545 and 640 mm <sup>2</sup>	FleXbus conductor 960, 1280 and 1810 mm <sup>2</sup>
1 x HCBC Clamp 63	1 x HCBC Clamp ≥ 100	2 x HCBC Clamp ≥ 100	2 x HCBC Clamp ≥ 100
2 x HCBC Plate 50	1 x HCBC Plate 100	2 x HCBC Plate 100	4 x HCBC Plate 100
			

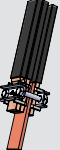
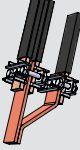
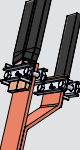
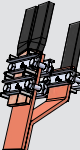
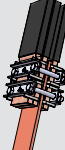
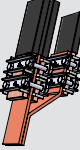
3 FleXbus Conductors per phase					
FleXbus conductor 220 and 360 mm <sup>2</sup>	FleXbus conductor 220, 360, 545 and 640 mm <sup>2</sup>	FleXbus conductor 220 and 360 mm <sup>2</sup>	FleXbus conductor 545 and 640 mm <sup>2</sup>	FleXbus conductor 960 mm <sup>2</sup>	FleXbus conductor 960, 1280 and 1810 mm <sup>2</sup>
1 x HCBC Clamp 63	2 x HCBC Clamp 63	1 x HCBC Clamp ≥ 100 1 x HCBC Clamp ≥ 63	2 x HCBC Clamp ≥ 100 1 x HCBC Clamp ≥ 63	2 x HCBC Clamp ≥ 100	4 x HCBC Clamp ≥ 100
2 x HCBC Plate 50	3 x HCBC Plate 50	1 x HCBC Plate 100 1 x HCBC Plate 50	2 x HCBC Plate 100 1 x HCBC Plate 50	4 x HCBC Plate 100	6 x HCBC Plate 100
					

Transformer palms or rigid bars cross section to be determined in function of the current to carry and ambient temperature.

# HCBC Clamp and Plate

## Mounting

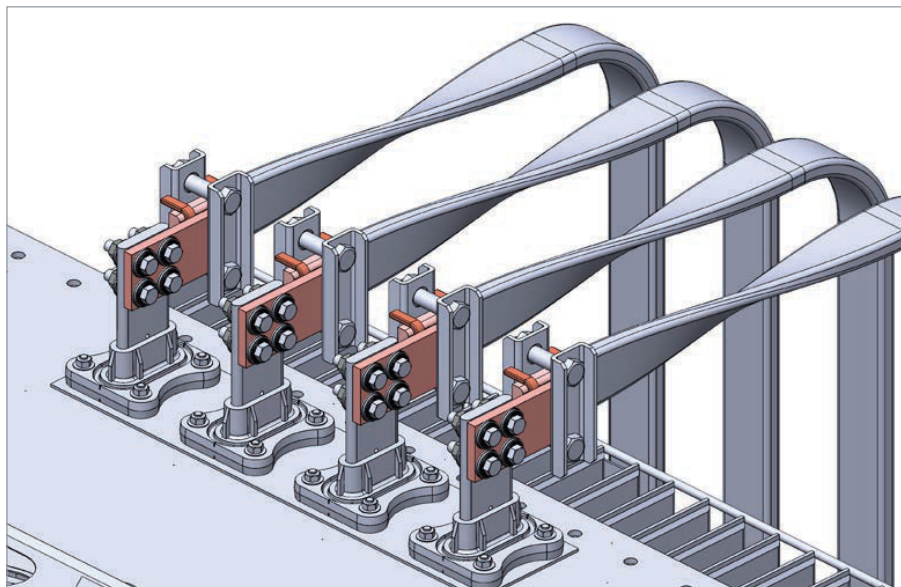
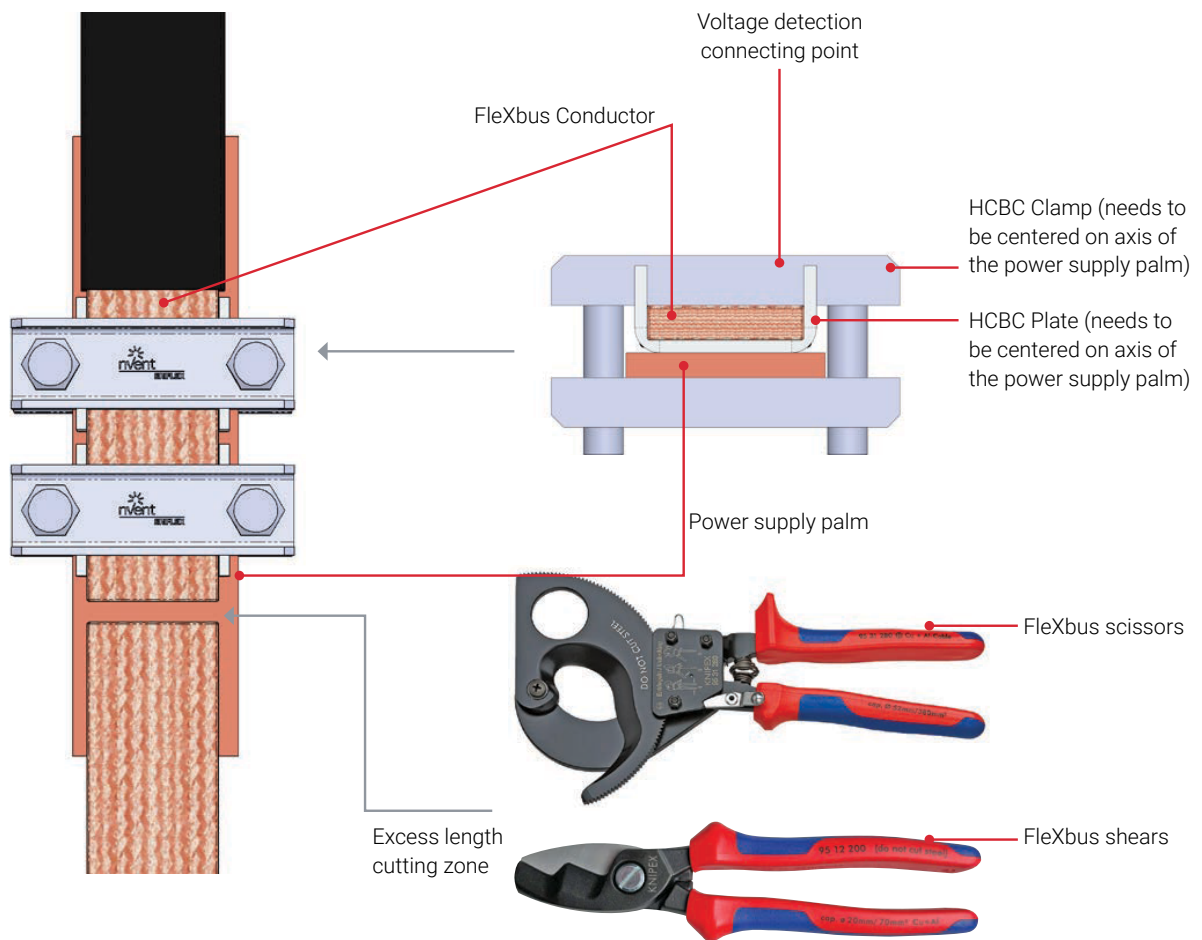

**Note:** If the Flexbus Conductor entry is horizontal, a palm extender is required between the power supply palm and HCBC clamp and plate as shown in the illustration.

[nVent.com/ERIFLEX](http://nVent.com/ERIFLEX) | 75

























# HCBC Clamp and Plate

## Transformer Palm Mounting

General Information

Technical Data

Other Data

Transfo Type	In Transformer (A)	Typical Usage For Oil Transformer 				Typical Usage For Dry/Cast Resin Transformer 				HCBC Clamp & Plate Mounting
		Transformer Palm Dimension (mm)	HCBC Clamp & Plate Mounting Per Phase	Transformer Palm Dimension (mm)	HCBC Clamp & Plate Mounting Per Phase	Transformer Palm Dimension (mm)	HCBC Clamp & Plate Mounting Per Phase	Transformer Palm Dimension (mm)	HCBC Clamp & Plate Mounting Per Phase	
		EN 50387		DIN 42530		EN 50180		DIN 46206		
400 kVA	560						HCBC Clamp 63 x 1pc HCBC Plate 50 x 1pc Clamping Torque: 100N.m			
500 kVA	704		HCBC Clamp 63 x 1pc HCBC Plate 50 x 1pc Clamping Torque: 100N.m		HCBC Clamp 63 x 1pc HCBC Plate 50 x 1pc Clamping Torque: 100N.m				HCBC Clamp 63 x 1pc HCBC Plate 50 x 1pc Clamping Torque: 100N.m	
630 kVA	900						HCBC Clamp 80 x 1pc HCBC Plate 50 x 1pc Clamping Torque: 100N.m			
800 kVA	1120									
1000 kVA	1400		HCBC Clamp 100 x 1pc HCBC Plate 100 x 1pc Clamping Torque: 100N.m		HCBC Clamp 100 x 1pc HCBC Plate 50 x 1pc Clamping Torque: 100N.m					
1250 kVA	1760						HCBC Clamp 100 x 1pc HCBC Plate 100 x 1pc Clamping Torque: 100N.m			
1600 kVA	2253		HCBC Clamp 100 x 2pc HCBC Plate 100 x 2pc Clamping Torque: 100N.m		HCBC Clamp 120 x 2pc HCBC Plate 100 x 2pc Clamping Torque: 100N.m		HCBC Clamp 100 x 2pc* HCBC Plate 100 x 2pc Clamping Torque: 100N.m		HCBC Clamp 120 x 2pc* HCBC Plate 100 x 2pc Clamping Torque: 100N.m	
2000 kVA	2816									
2500 kVA	3520		HCBC Clamp 120 x 2pc HCBC Plate 100 x 4pc Clamping Torque: 100N.m		HCBC Clamp 120 x 2pc HCBC Plate 100 x 4pc Clamping Torque: 100N.m		HCBC Clamp 160 x 2pc HCBC Plate 100 x 4pc Clamping Torque: 100N.m			
3150 kVA	4435									

\* transformer palm height increase may be needed.

**Note:** The minimum clearance distance is 14 mm according to IEC 61439-1 with air pollution degree 3.

If this distance cannot be respected, insulation material should be added between the metallic LV cover and the HCBC Clamp. Flexbus IP2x Boots are also a solution.

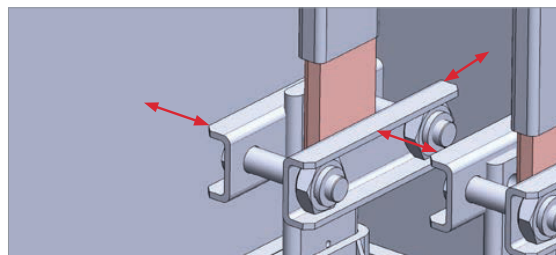

# Optional Extender

## Technical Specifications

If Flexbus Conductors cannot be connected directly to the switchboard busbar or electrical device (circuit breaker, load break switch, etc.), extenders can be used to make the connection.

Our extenders are made with electrolytic copper Cu-ETP 99.9% purity and are designed to extend the Flexbus Conductors. They are delivered with the appropriate countersunk head screws, nuts and washers.



Part Number	Global Part Number	Description	A (mm)	B (mm)	C (mm)	Packing Unit	Weight (Kg)
508110	FLEXEXT50A1	Flexbus Extender 50x10 for conductor 220, 360 and 545 mm <sup>2</sup> Type 1	50	10	113.5	1 pc	0.476
508111	FLEXEXT50A2	Flexbus Extender 50x10 for conductor 220, 360 and 545 mm <sup>2</sup> Type 2	50	10	113.5	1 pc	0.552
508112	FLEXEXT50A3	Flexbus Extender 50x10 for conductor 220, 360 and 545 mm <sup>2</sup> Type 3	50	10	168	1 pc	0.832
508113	FLEXEXT50B1	Flexbus Extender 50x10 for conductor 640 mm <sup>2</sup> Type 1	50	10	180.5	1 pc	0.786
508114	FLEXEXT50B2	Flexbus Extender 50x10 for conductor 640 mm <sup>2</sup> Type 2	50	10	180.5	1 pc	0.894
508115	FLEXEXT50B3	Flexbus Extender 50x10 for conductor 640 mm <sup>2</sup> Type 3	50	10	230	1 pc	1.158
508116	FLEXEXT1001	Flexbus Extender 100x10 for conductor 960, 1280 and 1810 mm <sup>2</sup> Type 1	100	10	206	1 pc	1.82
508117	FLEXEXT1002	Flexbus Extender 100x10 for conductor 960, 1280 and 1810 mm <sup>2</sup> Type 2	100	10	206	1 pc	2.03
508118	FLEXEXT1003	Flexbus Extender 100x10 for conductor 960, 1280 and 1810 mm <sup>2</sup> Type 3	100	10	255	1 pc	2.55

Type 1	Type 2	Type 3
Predrilled	Plain	Plain
Flat	Flat	Bended

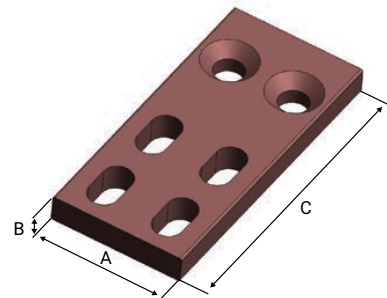

508110: Flexbus Extension 50x10 for conductor 220, 360 and 545 mm<sup>2</sup> Type 1

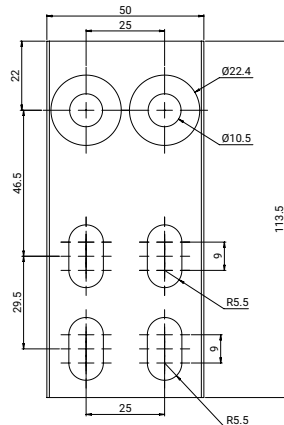

508111: Flexbus Extension 50x10 for conductor 260, 360 and 545 mm<sup>2</sup> Type 2

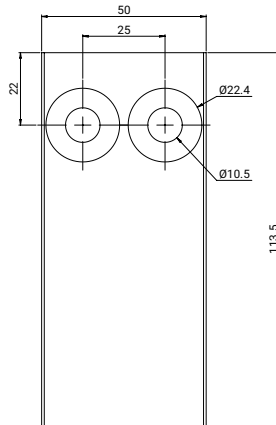

508112: Flexbus Extension 50x10 for conductor 260, 360 and 545 mm<sup>2</sup> Type 3

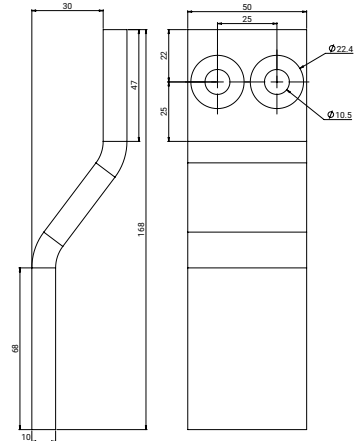

[nVent.com/ERIFLEX](http://nVent.com/ERIFLEX) | 77

# Optional Extender

## Technical Specifications

508113: Flexbus Extension 50x10 for conductor 640 mm<sup>2</sup> Type 1

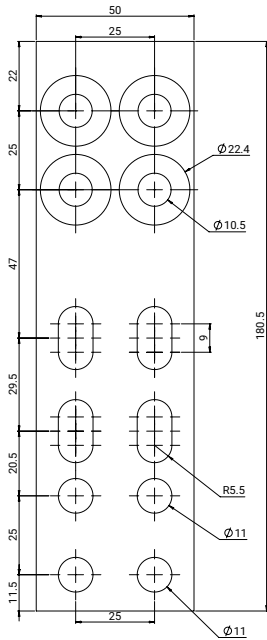

508114: Flexbus Extension 50x10 for conductor 640 mm<sup>2</sup> Type 2

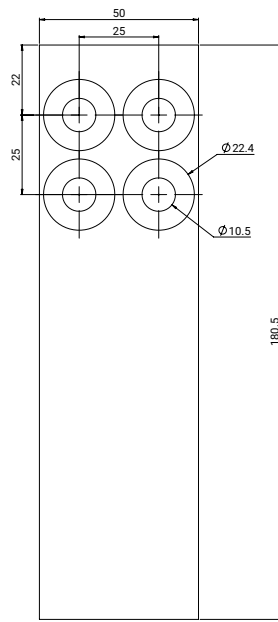

508115: Flexbus Extension 50x10 for conductor 640 mm<sup>2</sup> Type 3

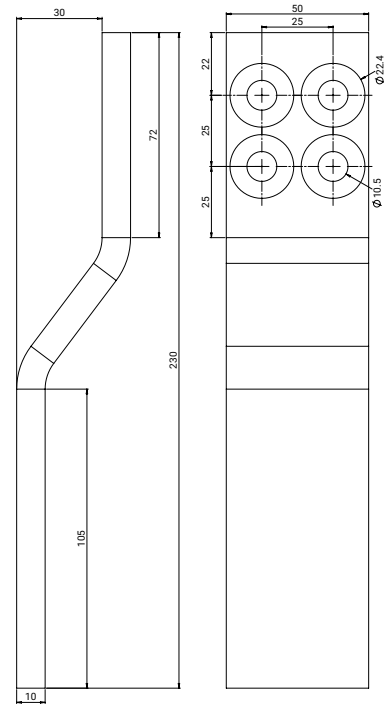

508116: Flexbus Extension 100x10 for conductor 960, 1280 and 1810 mm<sup>2</sup> Type 1

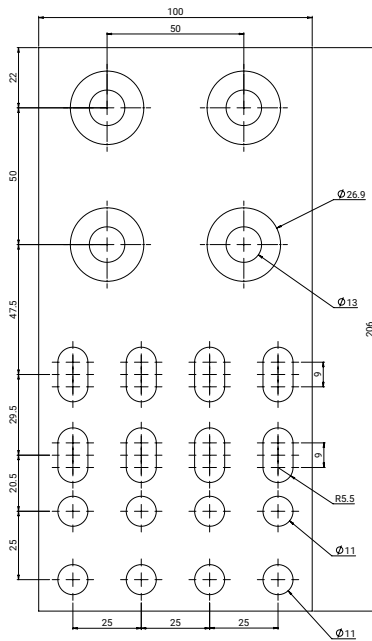

508117: Flexbus Extension 100x10 for conductor 960, 1280 and 1810 mm<sup>2</sup> Type 2

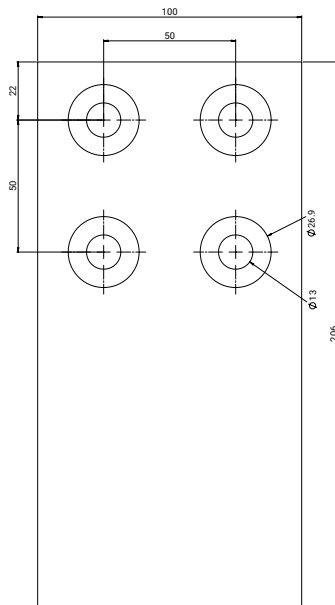

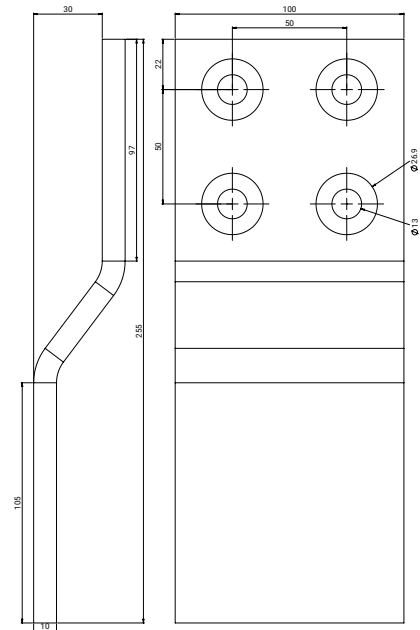

508118: Flexbus Extension 100x10 for conductor 960, 1280 and 1810 mm<sup>2</sup> Type 3

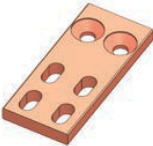

# Optional Extender

## Type 1 – Mounting on Punched Busbars

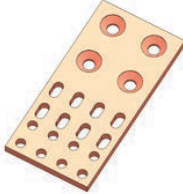
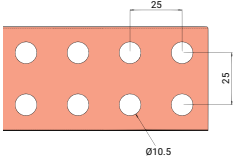
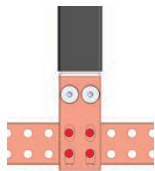
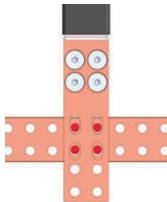
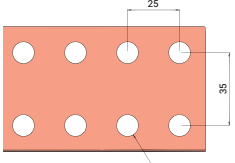
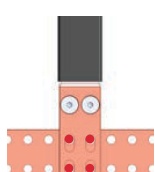
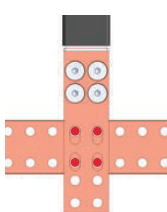
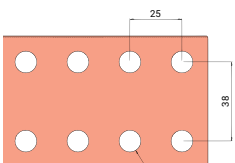
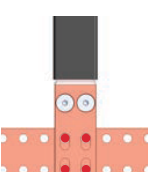
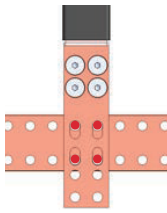
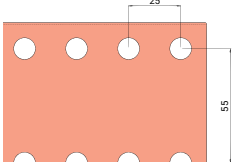
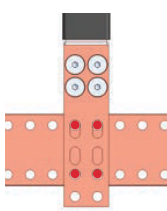
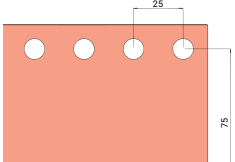
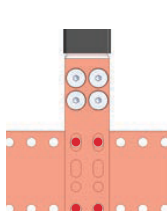
Extender Type 1 (Predrilled & Flat) – Mounting on Punched Busbars				
Part Number	508110	508113	508116	
Description	FleXbus Extender 50x10 for conductor 220, 360 and 545 mm <sup>2</sup> Type 1	FleXbus Extender 50x10 for conductor 640 mm <sup>2</sup> Type 1	FleXbus Extender 100x10 for conductor 960, 1280 and 1810 mm <sup>2</sup> Type 1	
Extender Type 1 Overview				
DPCB Punched Plain Copper Busbar, Double				
Cross Section 50x10 or 50x5				6 bolts min
Cross Section 60x10				6 bolts min
Cross Section 63x5				6 bolts min
Cross Section 80x5 or 80x10				6 bolts min
100x5 or 100x10				6 bolts min

nVent.com/ERIFLEX | 79

# Support Kits - Edge and Flat

## Technical Specifications

		FlexBus Support
<b>1</b> Support Kit	<b>Material</b>	Glass Fiber Reinforced Polyamide
	<b>Working Temperature</b>	-40 to 130°C
	<b>Flammability Rating</b>	UL® 94V-0 IEC® 60695-2-12 (Glow Wire Test 960°C)
	<b>Dielectric Strength, UL</b>	1,500 VAC/DC
	<b>Dielectric Strength, IEC 61439.1</b>	3,500 VAC @ 1 min
	<b>Insulation Voltage</b>	1,000 VAC; 1,500 VDC IEC
	<b>Halogen-Free Rating</b>	IEC® 60754-1
	<b>Low-Smoke Rating</b>	ISO 5659-2
<b>2</b> Aluminum Profile	<b>Material</b>	Aluminum
<b>3</b> Threaded Rods/Hardware	<b>Material</b>	Steel 8.8 Class
	<b>Finish</b>	Electrogalvanized
Installation Usage	<b>Complies With</b>	IEC® 61439.1 IEC® 61914 CE RoHS
	<b>International</b>	IEC 60364
	<b>Europe</b>	HD384
	<b>National</b>	AS 3008 ÖNORM RGIE – AREI NBR 5410 CSN NFC 15-100 DIN VDE 0100 CEI 64-8 NEN 1010 NP (2002) REBT NIBT-NIN BS 7671 SS 436 40 00

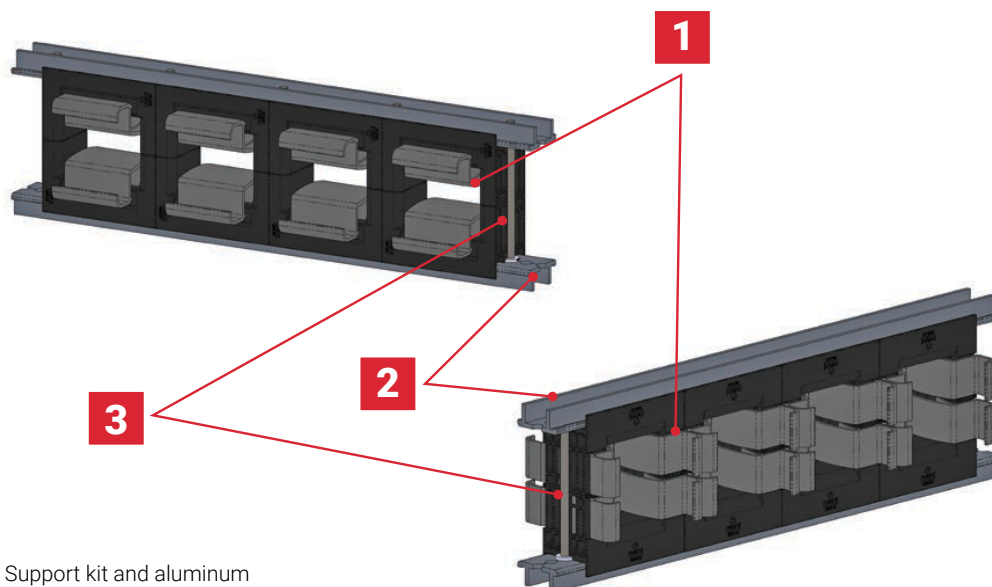

**Note:** Support kit and aluminum profile are ordered separately.

80 | [nVent.com/ERIFLEX](http://nVent.com/ERIFLEX)



# Support Kits - Edge and Flat

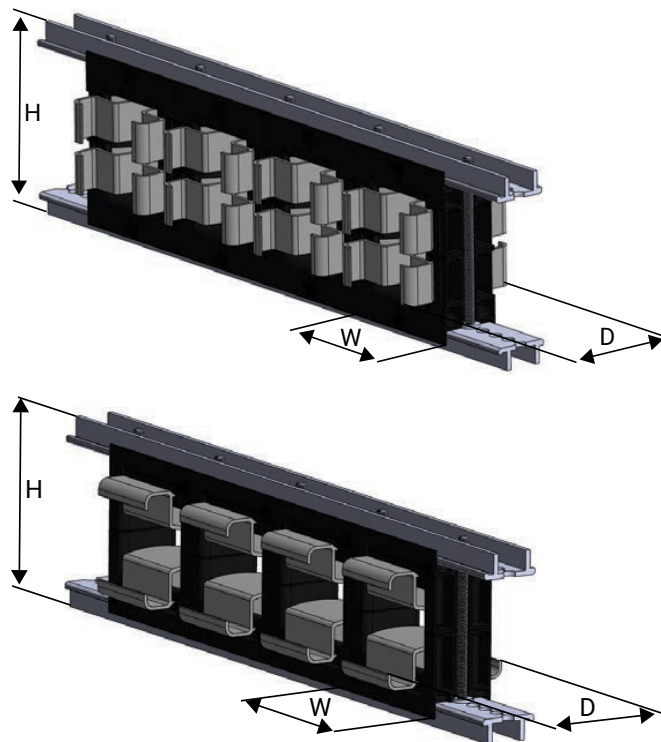

## Dimensions and Weight

Part Number	Global Part Number	Description	W (mm)	D (mm)	H (mm)	Packing Unit	Weight (Kg)
508101	FLEXSUPEDG50T	Flexbus Support Kit Edge for Conductor 220, 360, 545 and 640 mm <sup>2</sup> , 3 Poles	87.5	78.5	123.5	1pc	1.244
508102	FLEXSUPEDG50TN	Flexbus Support Kit Edge for Conductor 220, 360, 545 and 640 mm <sup>2</sup> , 3 Poles + Neutral	87.5	78.5	123.5	1pc	1.326
508103	FLEXSUPEDG100T	Flexbus Support Kit Edge for Conductor 960, 1280 and 1810 mm <sup>2</sup> , 3 Poles	100	78.5	175.5	1pc	1.520
508104	FLEXSUPEDG100TN	Flexbus Support Kit Edge for Conductor 960, 1280 and 1810 mm <sup>2</sup> , 3 Poles + Neutral	100	78.5	175.5	1pc	2.000
508105	FLEXSUPFLA50T	Flexbus Support Kit Flat for Conductor 220, 360, 545 and 640 mm <sup>2</sup> , 3 Poles	87.5	78.5	119.5	1pc	1.298
508106	FLEXSUPFLA50TN	Flexbus Support Kit Flat for Conductor 220, 360, 545 and 640 mm <sup>2</sup> , 3 Poles + Neutral	87.5	78.5	119.5	1pc	1.645
508107	FLEXSUPFLA100T	Flexbus Support Kit Flat for Conductor 960, 1280 and 1810 mm <sup>2</sup> , 3 Poles	138	78.5	125.5	1pc	1.960
508108	FLEXSUPFLA100TN	Flexbus Support Kit Flat for Conductor 960, 1280 and 1810 mm <sup>2</sup> , 3 Poles + Neutral	138	78.5	125.5	1pc	2.306

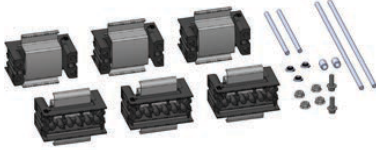

# Support Kits - Edge and Flat

## Dimensions and Weight

Support Kit Type	Edge	Flat
3P		
	508101 Flexbus Support Kit Edge for Conductor 220, 360, 545 and 640 mm <sup>2</sup> , 3 Poles	508105 Flexbus Support Kit Flat for Conductor 220, 360, 545 and 640 mm <sup>2</sup> , 3 Poles
3P+N		
	508102 Flexbus Support Kit Edge for Conductor 220, 360, 545 and 640 mm <sup>2</sup> , 3 Poles + Neutral	508106 Flexbus Support Kit Flat for Conductor 220, 360, 545 and 640 mm <sup>2</sup> , 3 Poles + Neutral
	508104 Flexbus Support Kit Edge for Conductor 960, 1280 and 1810 mm <sup>2</sup> , 3 Poles + Neutral	508108 Flexbus Support Kit Flat for Conductor 960, 1280 and 1810 mm <sup>2</sup> , 3 Poles + Neutral

## Aluminum Perforated Profile: Dimensions and Weight

Part Number	Global Part Number	Description	H (mm)	L (mm)	W (mm)	HS (mm)	A (mm)	Packing Unit	Weight (Kg)
508100	FLEXALPROF2M	Flexbus Aluminum Perforated Profile 2 Meter	15	2000	35	8	12.5	4pc	0.9

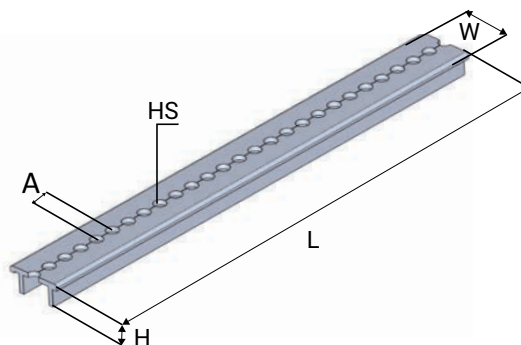

**Note:** Support Kit and Aluminum Profile are ordered separately

# Supports - Edge and Flat

## Mounting Possibilities

### INSTALLATION POSSIBILITIES:

- Directly on wall or ceiling
- On wire basket cable trays
- On perforated cable trays
- On ladder cable trays
- All possible orientations (horizontal/vertical)

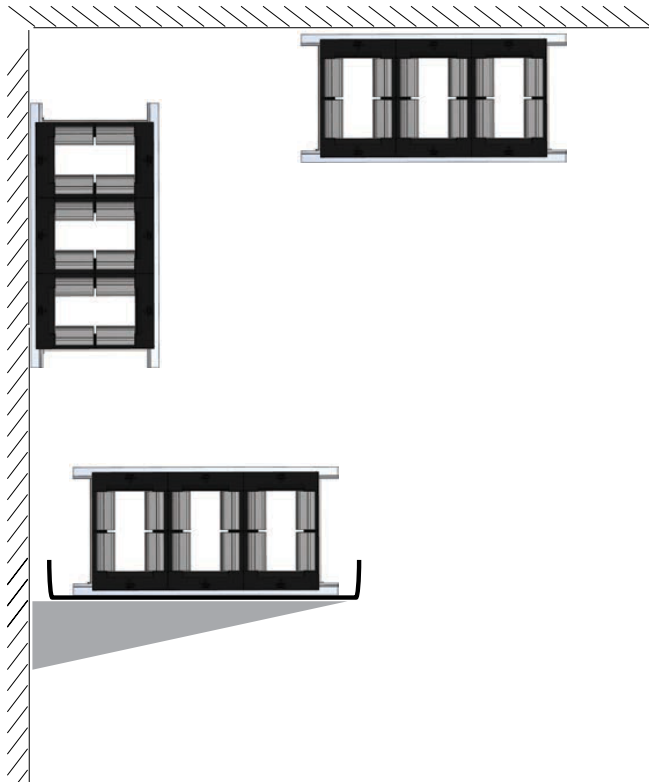



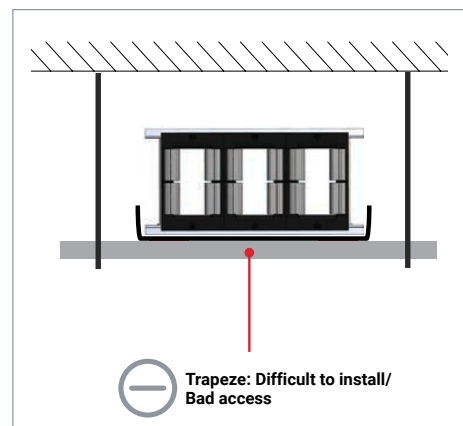
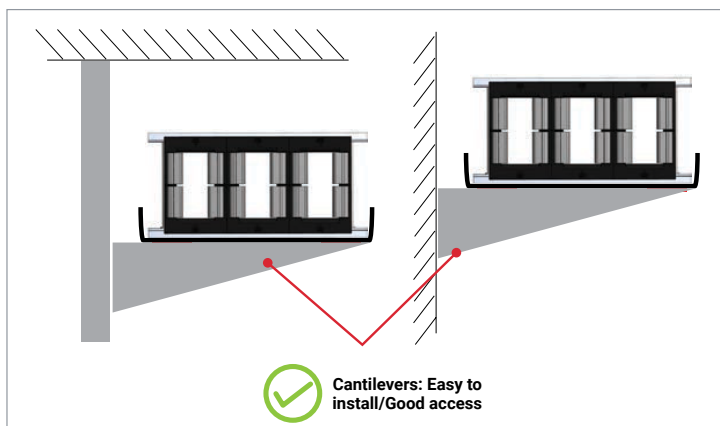
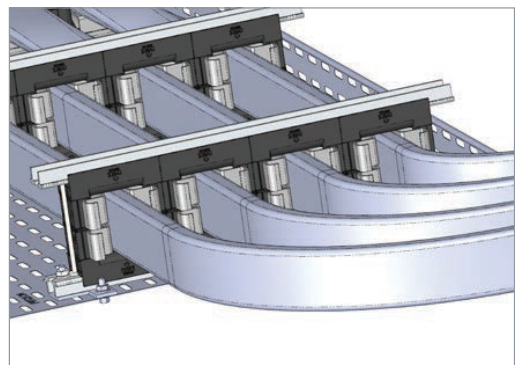
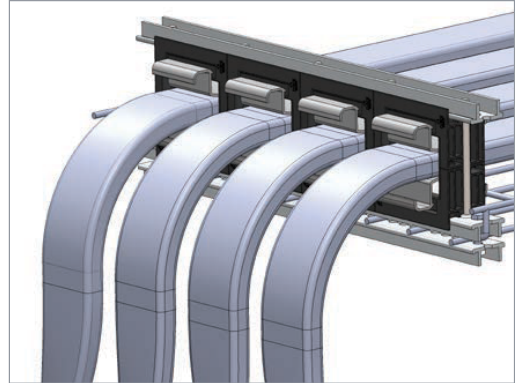
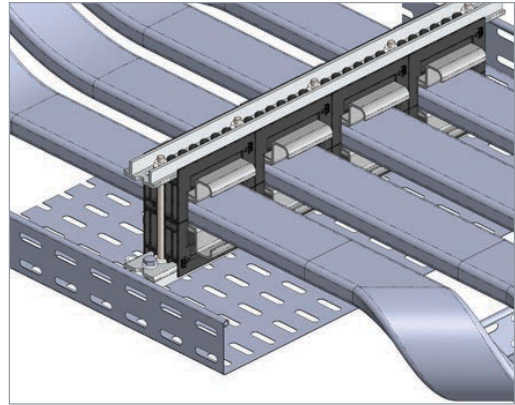



**Note:** For ease of installation of the Flexbus Conductors on cable trays, we recommend using a cantilever system in order to have easy and direct access during the installation phase.

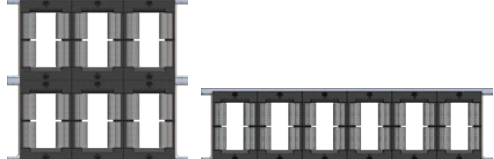
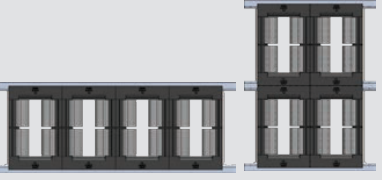

# Supports - Edge and Flat

## Possible Configurations

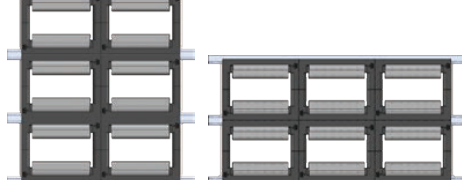
Configuration	Edge Support Kit	
	One Conductor Per Phase 	Two Conductors Per Phase 
3P		
3P+N		

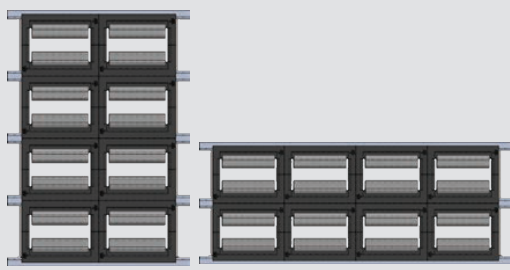
Configuration	Flat Support Kit	
	One Conductor per Phase 	Two Conductors per Phase 
3P		
3P+N		

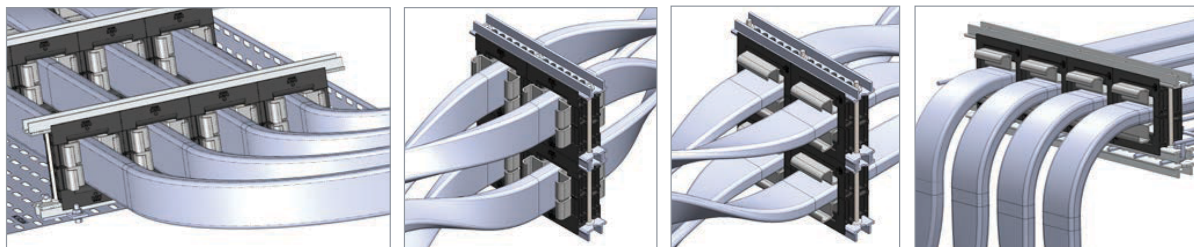

# Support Brackets

## Dimensions and Weight

- Attaches aluminum perforated profile to the structures
- RoHS compliant
- Material: Steel
- Finish: Electrogalvanized

Part Number	Global Part Number	Description	Packing Unit	Weight (Kg)
549410	CABS-E	BRACKET CABS – E	10pc	0.046
549420	CABS-M	BRACKET CABS – M	10pc	0.2
549400	CABS-T	BRACKET CABS – T	5pc	0.11

Bracket CABS – E

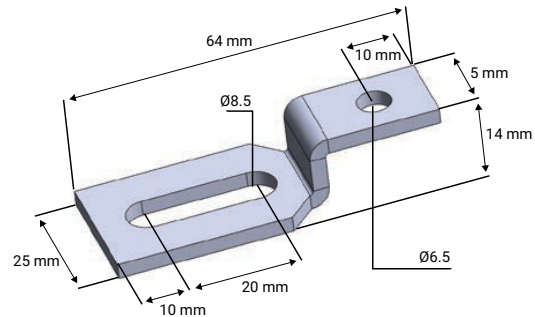

Bracket CABS – M

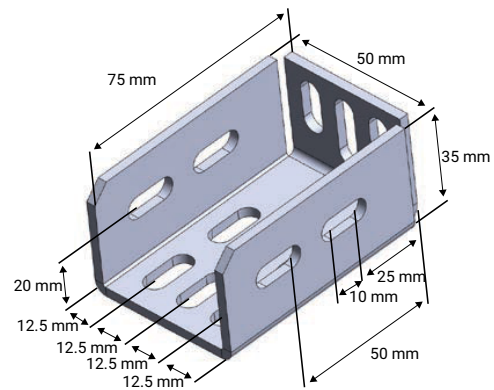

Bracket CABS – T

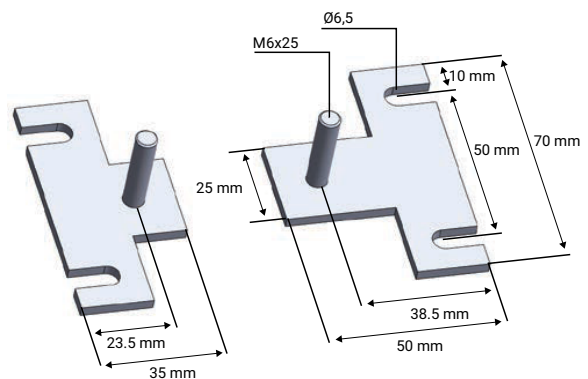
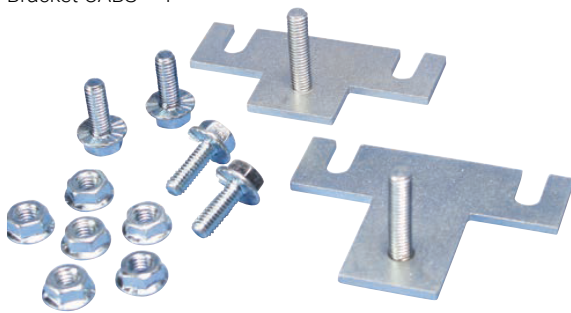

nVent.com/ERIFLEX | 85

# Supports

## Possible Configuration With 200% Neutral or PE+N Conductor

### 200% NEUTRAL CONFIGURATION

As seen on Page 65, "Conductor - Harmonics," from this catalog, when the third harmonic level is higher than 33%, the neutral conductor should be sized at 200% from the

phase conductors. An example how this configuration can be installed with the Flexbus supports is shown in the illustrations below.

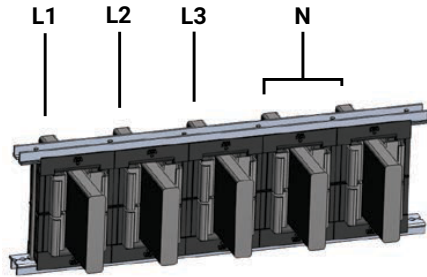

**Example:**  
Flexbus Conductors  
960 mm<sup>2</sup> x 5

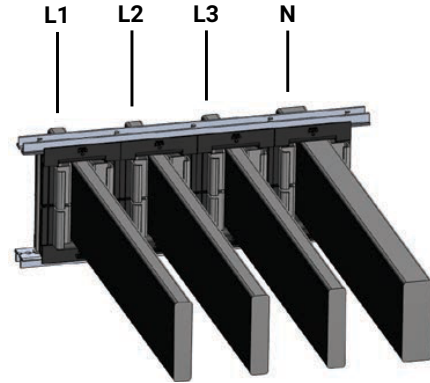

**Example:**  
Flexbus Conductors  
220 mm<sup>2</sup> x 3  
545 mm<sup>2</sup> x 1

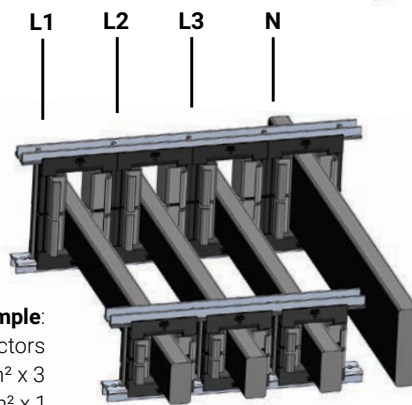

**Example:**  
Flexbus Conductors  
640 mm<sup>2</sup> x 3  
1280 mm<sup>2</sup> x 1

### 3PHASE + N + PE CONFIGURATION

A protective earthing (PE) conductor is needed with a TN-S neutral system.

According to IEC and other related standards, the Flexbus Conductor can act as the PE conductor with half the cross section of the phase conductors.

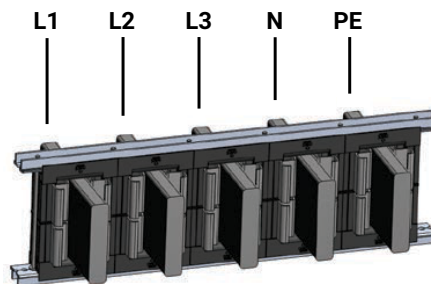

**Standard reference:**

IEC 60364 Low-Voltage Electrical Installations

Part 5-54: Selection and erection of electrical equipment – Earthing arrangements and protective conductors. Chapter 543 – Protective conductors

# Supports

## Grounding

FleXbus conductors have a Class II insulation grade. This means that if the FleXbus supports are not installed on a continuous metallic structure or metallic cable tray, the individual support will not need to be connected to the local earth network, as contact with the support is made through reinforced insulated material.

In Class II material-graded products, the protection against electric shock is not based solely on primary insulation but includes additional safety measures, such as double or reinforced insulation.

These measures do not require protective earthing and are not dependent on installation conditions.

Class II products are self-sufficient in safety and do not require any other provision for protection against indirect contact.

This means that the equipment is designed in such a way that any fault between the active and accessible parts is unlikely and improbable

**X** Possible, but not mandatory, not necessary

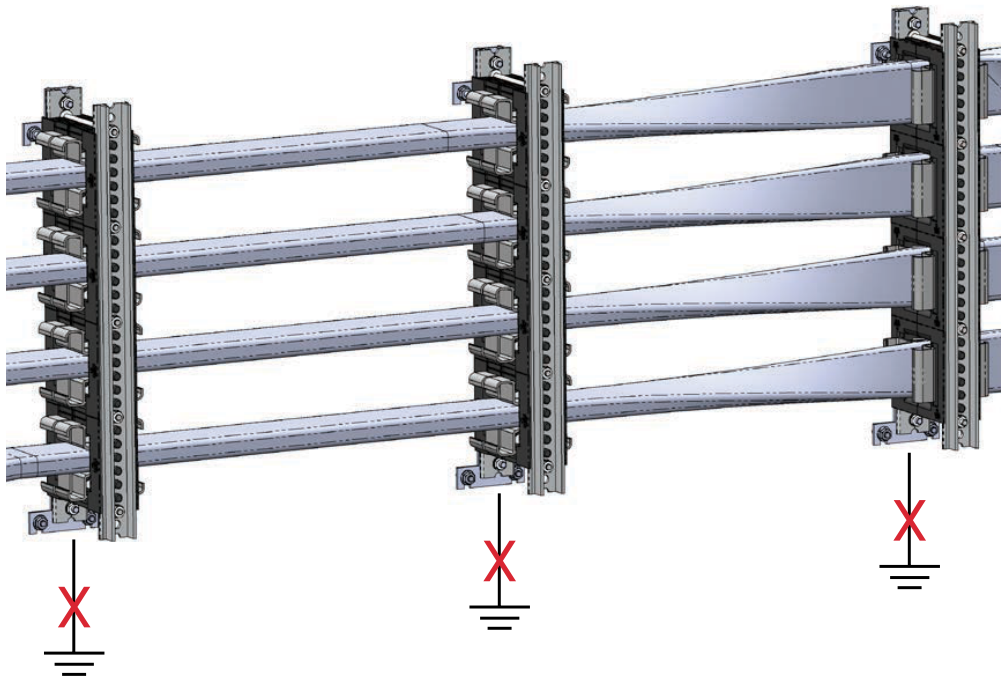













# Supports

## Recommended Cable Tray Size













**Flexbus supports can be fixed directly on a wall or ceiling without the use of cable tray.** However, if wire, perforated or ladder cable tray is used, the table below provides minimum cable tray width recommendations.

### 3P+N SYSTEM

Power Supply	Recommended Flexbus Conductors Per Phase		Minimum Cable Tray Width (mm)								
	400 kVA	1x220 mm <sup>2</sup>	FLEXCOND220		400		300		150		400
	500 kVA	1x360 mm <sup>2</sup>	FLEXCOND360								
	630 kVA	1x545 mm <sup>2</sup>	FLEXCOND545		400		300		200		400
	800 kVA	1x640 mm <sup>2</sup>	FLEXCOND640								
	1000 kVA	1x960 mm <sup>2</sup>	FLEXCOND960								
	1250 kVA	1x1280 mm <sup>2</sup>	FLEXCOND1280								
	1600 kVA	1x1810 mm <sup>2</sup>	FLEXCOND1810		500		500		400		600
	2000 kVA	2x960 mm <sup>2</sup>	FLEXCOND960 x 2								
	2500 kVA	2x1280 mm <sup>2</sup>	FLEXCOND1280 x 2								
	3150 kVA	2x1810 mm <sup>2</sup>	FLEXCOND1810 x 2								

Note: Standard available cable tray width: 50/100/150/200/300/400/500

### 3P SYSTEM

Power Supply	Recommended Flexbus Conductors Per Phase		Minimum Cable Tray Width (mm)								
	400 kVA	1x220 mm <sup>2</sup>	FLEXCOND220		300		150		300		400
	500 kVA	1x360 mm <sup>2</sup>	FLEXCOND360								
	630 kVA	1x545 mm <sup>2</sup>	FLEXCOND545		400		200		500		400
	800 kVA	1x640 mm <sup>2</sup>	FLEXCOND640								
	1000 kVA	1x960 mm <sup>2</sup>	FLEXCOND960								
	1250 kVA	1x1280 mm <sup>2</sup>	FLEXCOND1280								
	1600 kVA	1x1810 mm <sup>2</sup>	FLEXCOND1810		400		700		500		400
	2000 kVA	2x960 mm <sup>2</sup>	FLEXCOND960 x 2								
	2500 kVA	2x1280 mm <sup>2</sup>	FLEXCOND1280 x 2								
	3150 kVA	2x1810 mm <sup>2</sup>	FLEXCOND1810 x 2								

Note: Standard available cable tray width: 50/100/150/200/300/400/500

**Note:** When a cable tray is used, we recommend installing a Flexbus support at each extremity, in order to protect the Flexbus Conductors against potential sharp edges on the cable tray.

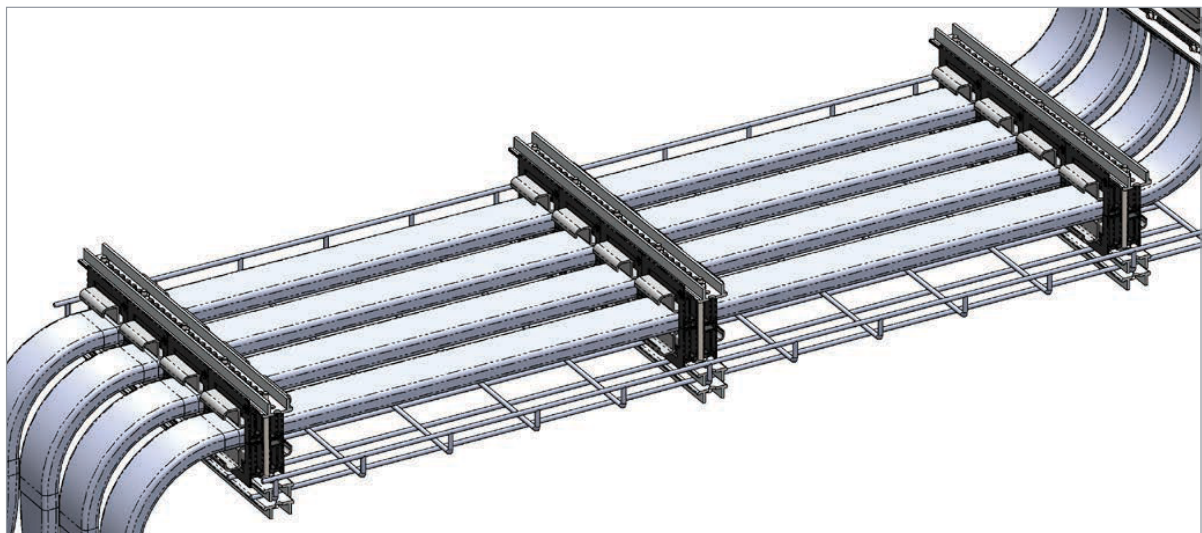



# Supports

## nVent CADDY – Fixing and Fastening Solutions for your Flexbus Installation



#	Picture	Range	QR Code	Part Number Examples	Application Picture
①		Wire Basket Tray		EU: WBT60X400QEG NA: WBT2X16 APAC: N/A	
②		Wire Basket Tray Clip		EU: KBT NA: KBT APAC: KBT	
③		Strut Cantilever Arm		EU: KA25H0600EG NA: KA25H0600EG APAC: KH13C	
④		Strut Channel		EU: A25H3000PG NA: A12H1000PG APAC: ES4141SLOTX6	
⑤		Strut Channel Fittings		EU: ZZA702 NA: W170000EG APAC: ZZA702	
⑥		Strut Channel Nuts and T-Bolts		EU: SPRAM8EG NA: SPRA0037EG APAC: SPRAM10HD	
⑦		ADK Strut End Cap		EU: ADK421 NA: ADK421GY APAC: ADK421	
⑧		Metal Anchors		EU: BSZSU10100EG NA: CSBCAS025037EG APAC: LAM1040	
⑨		Threaded Rod		EU: 050M81000 NA: 0503706EG APAC: 050M103000	
⑩		Wire Basket Tray Center Support		EU: WBTCTSPRTM6 NA: WASHER SUPPORT APAC: N/A	
Other useful solution for sub-stations					
⑪		C-EC Cable to Strut Clamp		EU: C70EC NA: N/A APAC: N/A	

nVent.com/ERIFLEX | 89

# Supports

## Phase Inversion, Neutral Rotation

Flexbus supports **can be rotated** to allow for complete or partial reverse of the phase and neutral conductors. They are normally used in connections between a power supply and an electric board, when the starting sequence is different from the arrival sequence.

### Phase and Neutral Inversion (version 1)

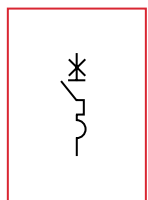
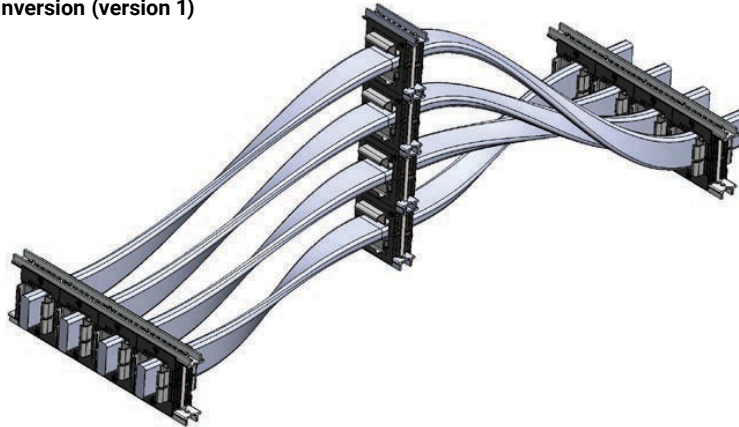

Switchboard side

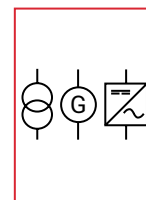
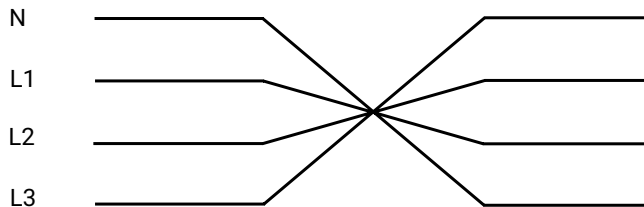

Power supply side



### Phase and Neutral Inversion (version 2)

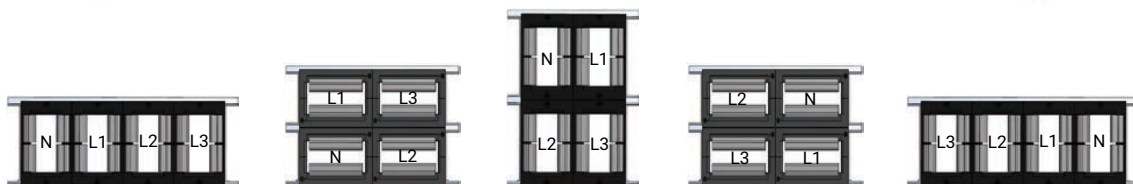
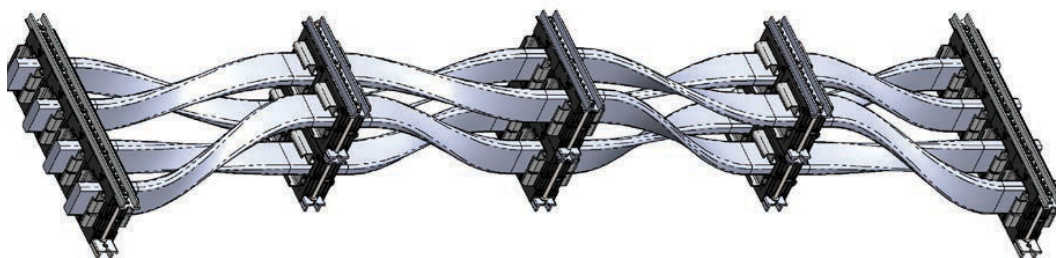

# Supports

## Phase Inversion, Neutral Rotation

### Neutral Rotation

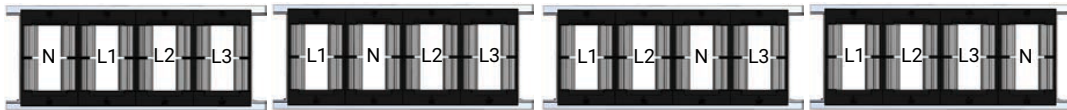
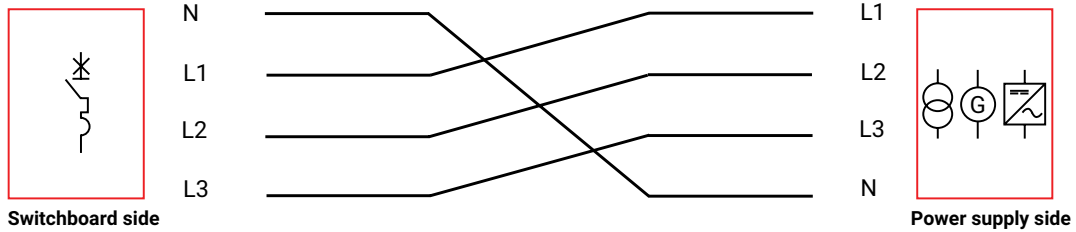
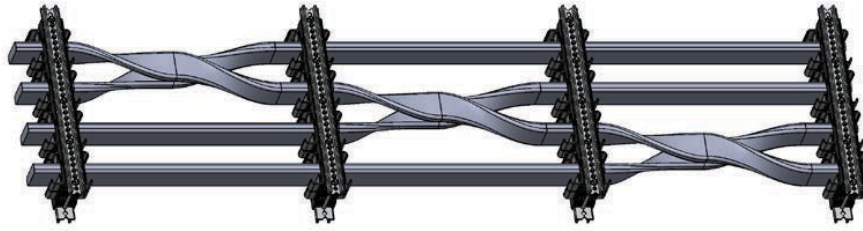

### Phase Rotation

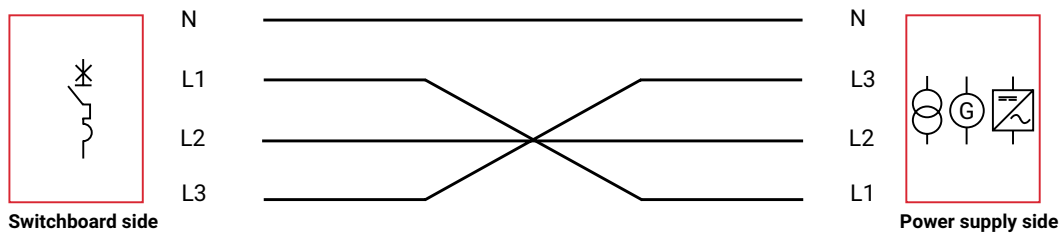
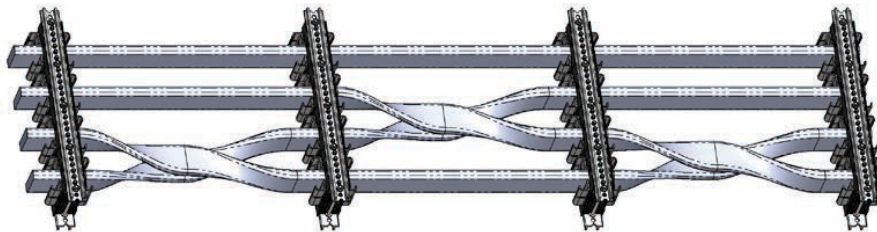

# Supports

## Short-Circuit – Fixing and Securing

**Electromagnetic Forces (Ipk)** are induced in conductors by the currents flowing through them. When parallel conductors are longer compared to the distance between them, the force will be evenly distributed along the conductors. The force is attractive when the currents in the two conductors have the same direction, resulting in a “pull” mechanical effect. When the directions of the currents are opposite, the forces are repulsive, resulting in a “push” mechanical effect.

Flexbus Conductors and supports have been tested under short-circuit conditions as per IEC 61914 (Cable cleats for electrical installations) up to 67 kA rms – 147 kA Peak.

The table below indicates the recommended minimum distance between supports to withstand the short-circuit, when upstream from the power supply.

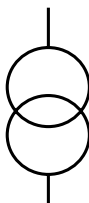
Oil Transformer Power	Typical Icc Short Circuit (kA rms)	Typical Icc Short Circuit (kA peak)	Recommended Flexbus Conductors Per Phase @30°C Ambient and 90°C at conductor	Max Distance Between Supports (mm)				
				1 Conductor Per Phase	2 Conductors Per Phase/ Symmetrical Laying	2 Conductors Per Phase/ Non-Symmetrical Laying	3 conductors per phase / Symmetrical Laying	
	400 kVA	13.8	27.6	1x220 mm <sup>2</sup>	1000			
	500 kVA	17.2	34.4	1x360 mm <sup>2</sup>	1000			
	630 kVA	21.5	45.2	1x360 mm <sup>2</sup>	1000			
	800 kVA	18.3	36.6	1x545 mm <sup>2</sup>	1000			
	1000 kVA	22.7	47.7	1x960 mm <sup>2</sup>	1000			
				2x360 mm <sup>2</sup>		1000	1000	
	1250 kVA	28.2	59.2	1x960 mm <sup>2</sup>	850			
				2x360 mm <sup>2</sup>		1000	1000	
	1600 kVA	35.7	75	1x1810 mm <sup>2</sup>	530			
				2x545 mm <sup>2</sup>		1000	1000	
	2000 kVA	44	92.4	2x960 mm <sup>2</sup>		1000	940	
				3x545 mm <sup>2</sup>				1000
	2500 kVA	54.2	119.2	2x960 mm <sup>2</sup>		1000	560	
				3x960 mm <sup>2</sup>		680	370	
3600 kVA	76	167	3x1280 mm <sup>2</sup>				1000	
4000 kVA	82	180	3x1810 mm <sup>2</sup>				970	
4500 kVA	95	209	3x1810 mm <sup>2</sup>				830	
							620	

Note: Icc values are given for 500 MVA upstream network and for oil transformers. For other application, please check with device manufacturer

For other short-circuit values or other applications, please use the graphic from the next page.

It is recommended to install a support at the minimum possible distance from the power supply palms.

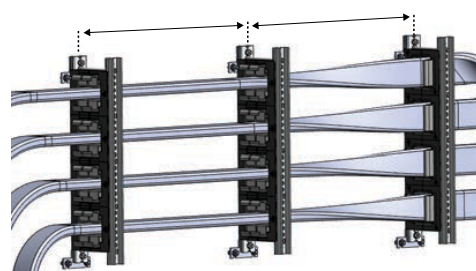
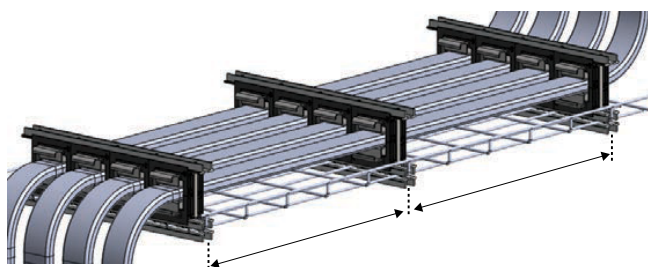

# Supports

## Short-Circuit – Fixing and Securing

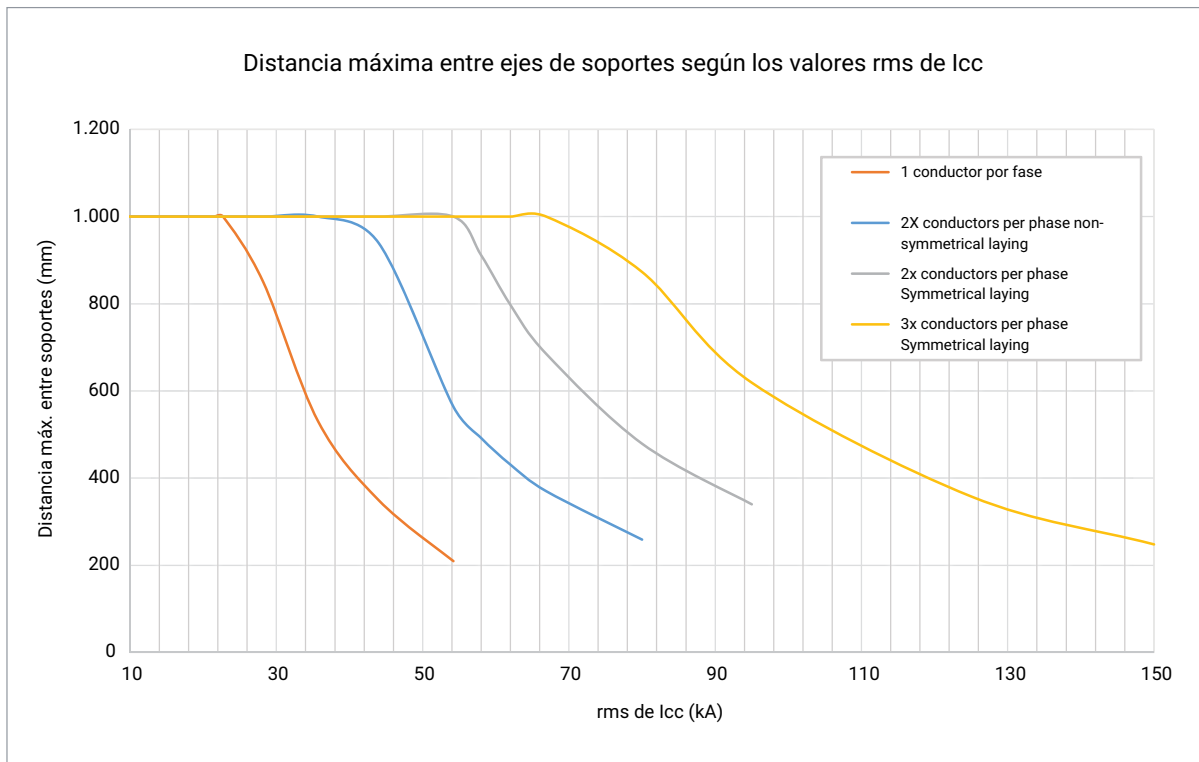

### Standard reference:

IEC 60364 Low-Voltage Electrical Installations

522.8.4 Where the conductors or cables are not supported continuously due to the method of installation, they shall be supported by suitable means at appropriate intervals in such a manner that the conductors or cables do not suffer damage by their own weight, or due to electro-dynamic forces resulting from short-circuit current.

522.8.11 Cable supports and enclosures shall not have sharp edges liable to damage the cables or insulated conductors.

522.8.12 Cables and conductors shall not be damaged by the fixing means.

# Fire Barrier

## Technical Specifications



FleXbus Fire Barrier is a kit to be used as a FleXbus Conductor penetration seal, based on the following components:

- **FBS** (EN or UL): Product in cartridges on the basis of polyurethane with intumescent fire protection additives. After application, it reacts and increases its volume.

- **FBB** (EN or UL): Block-shaped intumescent elastic product composed of polyurethane with intumescent fire protection additives.
- **FIB**: Intumescent wrap on the basis of butyl rubber with intumescent fire protection additives and glass fabric reinforcement.

	1 FBS-EN Foam Barrier	2 FBS-UL Foam Barrier	3 FBB-EN Firestop Block	4 FBB-UL Firestop Block	5 FIB Insulating Bandage	6 FFBD Foam Barrier Dispenser
<b>Part Number</b>	508150	508153	508151	508154	508152	508155
<b>Global Part Number</b>	FLEXFOAMBARRIER	FLEXFOAMBARUL	FLEXFIREBLOCK	FLEXFIREBLOCKUL	FLEXBANDAGE	FLEXFOAMDISPENS
<b>Packing Unit</b>	6pc	6pc	4pc	12pc	1pc	1pc
<b>Certification Details</b>	EN 1366-3 EN 13501-1	ASTM E 814 (UL 1479) ASTM E 84 (UL 723)	EN 1366-3 EN 13501-1	ASTM E 814 (UL 1479) ASTM E 84 (UL 723)	EN 1366-3 EN 13501-1	
<b>European Technical Assessment (ETA)</b>	ETA-17/0845	-	ETA-17/0845	-	ETA-17/0845	
<b>Contents</b>	380 ml					
<b>Dimensions</b>	-		200 mm x 144 mm x 60 mm	200 mm x 130 mm x 60 mm	5000 mm x 150 mm	
<b>Density</b>	≥ 215 kg/m <sup>3</sup>	-	240 kg/m <sup>3</sup> to 300 kg/m <sup>3</sup>	-		
<b>Temperature Resistance</b>	≤ 80°C					
<b>Construction Material Class</b>	B2 – as per DIN 4102	-	B2 – as per DIN 4102	-		
<b>Yield</b>	≤ 2.1 l	≤ 1.9 l	-			
<b>Cure Time</b>	Approx. 90 s					
<b>Color</b>	Red-brown					
<b>Shelf Life</b>	12 months from date of manufacturing					
<b>Storage Temperature</b>	+5°C to +30°C					
<b>Sound Transmission Class</b>	43.5 dB – 66 dB	-	43.5 dB – 66 dB	-		
<b>Application Temp Range</b>	+15°C to +30°C					
<b>Building Materials</b>	Concrete (wall and floors)/Masonry/Flexible wall					
<b>Weight (Kg)</b>	0.725		0.555		3.6	1.3

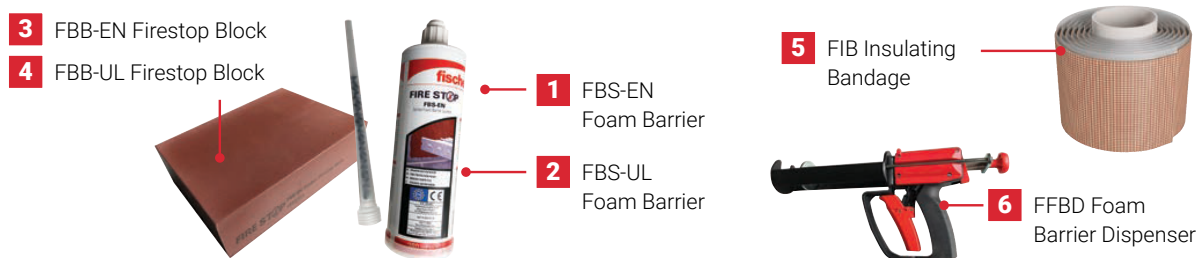

### INSTALLATION

1. Clean all contact surfaces so they are free from loose debris and contaminants.
2. Install the required backing material as per the detailed instruction or approved system.
3. Unscrew cap from cartridge and insert into the dispensing gun.
4. Discard non-uniform initial material.
5. Fill the opening from back to front. Build up the foam from bottom to top.
6. After 2 minutes, tool foam to a defect-free finish using a suitable knife.
7. FleXbus Conductors or other cables that will be installed retroactively can be routed through the existing foam. Refill gaps due to removed cables or pipes with FBS foam.

# Fire Barrier

## Mounting Information

### NOTES

- The thickness of the penetration seal has to be a minimum of 200 mm, depending on the fire resistance classification (see Annex J-1 of the ETA) in order to obtain EI120 fire resistance.
- If 200 mm is not possible, the FIB (intumescent wrap) needs to be used around Flexbus Conductors and with a 150 mm width on both sides in order to reach EI120 fire resistance.
- The maximum opening size of the penetration seal has to comply with the dimensions as specified below on this page (W: 450 mm Max/H: 500 mm Max).
- The total cross section of the installation (including insulation and conductor) must not be more than 60% of the opening size of the penetration seal.
- The first support for the Flexbus Conductor has to be at a maximum of 200 mm measured from the surface of the penetration seal.

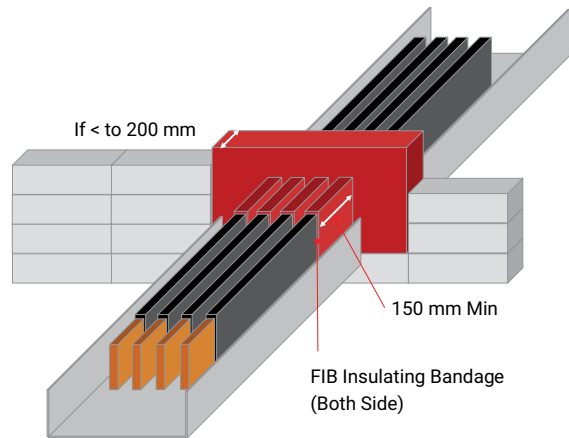
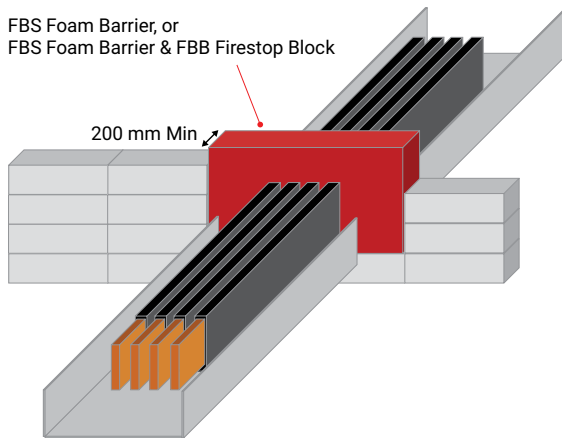
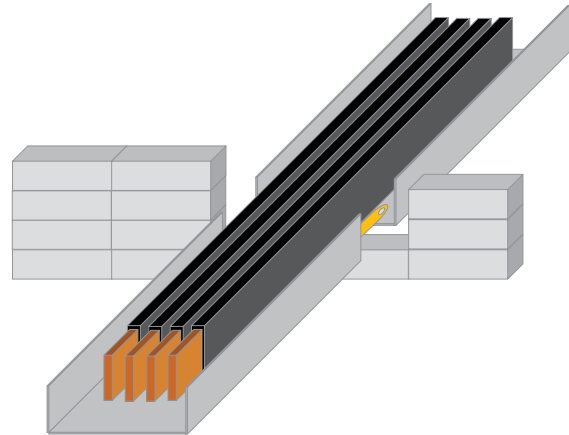
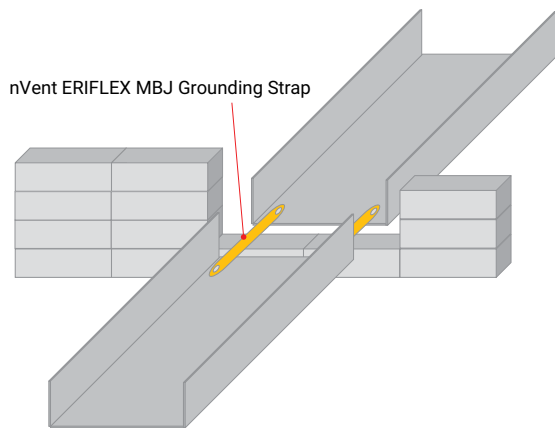
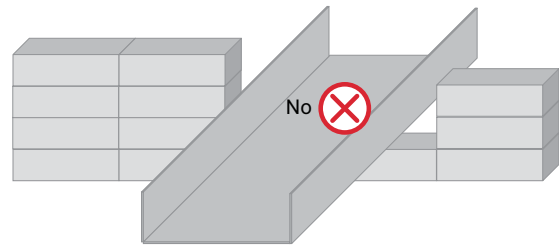
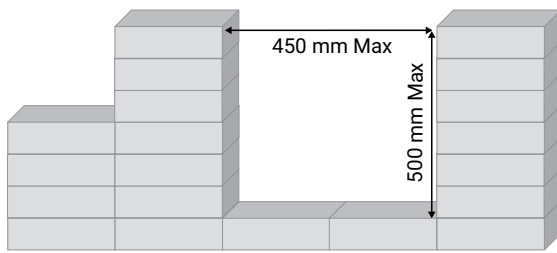

# Fire Barrier

## Mounting Information

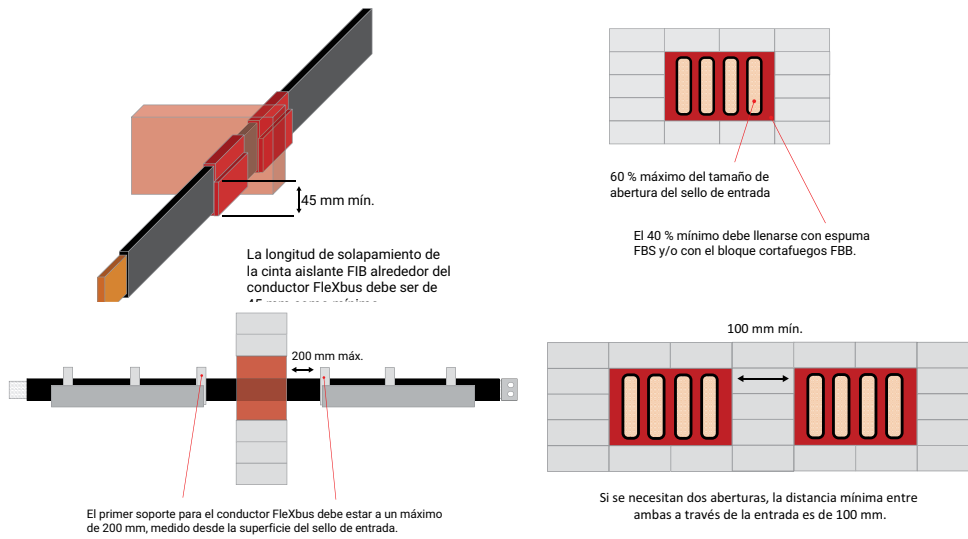

### MINIMUM OPENING SIZE OF THE PENETRATION SEAL (MM) AND QTY OF FOAM, BLOCK AND BANDAGE

Minimum Opening Size of the Penetration Seal (mm)	H W	3P+N									
		One Conductor Per Phase Configuration					Two Conductors Per Phase Configuration				
		□□□□	□□□□	□□□□	□□□□	□□□□	□□□□	□□□□	□□□□	□□□□	□□□□□□
Flexbus Conductor cross section	220, 360 545, 640 mm <sup>2</sup>	W : 420 H : 185	W : 180 H : 475	W : 270 H : 260	W : 445 H : 150	W : 240 H : 300	W : 420 H : 300	W : 270 H : 475	W : 445 H : 260	W : 420 x 2 H : 185 x 2	
	QTY Blocks FBB*	9	10	9	8	9	15	15	14	18	
	QTY Foam FBS**	2	2	2	2	2	3	3	3	4	
	QTY Bandage FIB***	1	1	1	1	1	1	1	1	1	
Flexbus Conductor cross section	960, 1280 1810 mm <sup>2</sup>	W : 465 H : 235	W : 230 H : 500	W : 370 H : 280	W : 370 x 2 H : 160 x 2	W : 265 H : 400	W : 465 H : 400	W : 370 H : 500	W : 370 x 2 H : 280 x 2	W : 465 x 2 H : 235 x 2	
	QTY Blocks FBB*	13	14	12	14	13	22	22	24	26	
	QTY Foam FBS**	3	3	3	3	3	5	5	5	6	
	QTY Bandage FIB***	1	1	1	1	1	2	2	2	2	

### MINIMUM OPENING SIZE OF THE PENETRATION SEAL (MM) AND QTY OF FOAM, BLOCK AND BANDAGE

Minimum Opening Size of the Penetration Seal (mm)	H W	3P						
		One Conductor Per Phase Configuration			Two Conductors Per Phase Configuration			
		□□□	□□□	□□□	□□□	□□□	□□□	□□□□
Flexbus Conductor cross section	220, 360 545, 640 mm <sup>2</sup>	W : 330 H : 185	W : 180 H : 370	W : 355 H : 150	W : 330 H : 300	W : 270 H : 370	W : 355 H : 260	W : 330 x 2 H : 185 x 2
	QTY Blocks FBB*	8	8	7	12	12	11	15
	QTY Foam FBS**	2	2	2	3	3	3	3
	QTY Bandage FIB***	1	1	1	1	1	1	1
Flexbus Conductor cross section	960, 1280 1810 mm <sup>2</sup>	W : 465 H : 235	W : 230 H : 400	W : 500 H : 160	W : 365 H : 400	W : 370 H : 400	W : 500 H : 280	W : 365 x 2 H : 235 x 2
	QTY Blocks FBB*	10	11	10	17	18	17	20
	QTY Foam FBS**	2	3	2	4	4	4	4
	QTY Bandage FIB***	1	1	1	1	1	1	1

\* FBB Firestop Blocks Packing unit is 4pc (12pc for North America / UL Version).

\*\* FBS Foam Barrier Packing unit is 6pc.

\*\*\* FIB Insulating Bandage Packing unit is 1pc. Need to be used only if wall thickness is < 200 mm.

Qty of Firestop Blocks FBB and Foam Barrier FBS from this table are given for a wall thickness of 200 mm. For other thickness, apply % ratio. Example : for 150 mm thickness, reduce by 25% the Qty.

For 3 Flexbus conductors per phase, please contact your nVent ERIFLEX representative

96 | [nVent.com/ERIFLEX](http://nVent.com/ERIFLEX)



# Fire Barrier

## Standard Reference

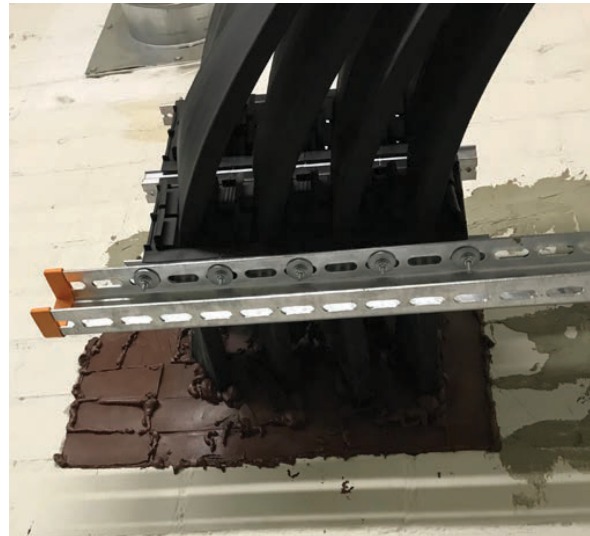

### Standard reference:

IEC 60364 Low-Voltage Electrical Installations

#### 523.8 Variation of installation conditions along a route

Where the heat dissipation differs in one part of a route to another, the current-carrying capacity shall be determined so as to be appropriate for the part of the route having the most adverse conditions.

NOTE This requirement can normally be neglected if heat dissipation only differs where the wiring is going through a wall of less than 0.35 m.

#### 527 Selection and erection of wiring systems to minimize the spread of fire

##### 527.1 Precautions within a fire-segregated compartment

527.1.1 The risk of spread of fire shall be minimized by the selection of appropriate materials and erection in accordance with Clause 527.

527.1.2 Wiring systems shall be installed so that the general building structural performance and fire safety are not reduced.

527.1.3 Cables complying with, at least, the requirements of IEC 60332-1-2 and products classified as non-flame propagating may be installed without special precautions.

##### 527.2 Sealing of wiring system penetrations

527.2.1 Where a wiring system passes through elements of building construction such as floors, walls, roofs, ceilings, partitions or cavity barriers, the openings remaining after passage of the wiring system shall be sealed according to the degree of fire resistance (if any) prescribed for the respective element of building construction before penetration (see the ISO 834 series).

#### 422 Precautions where particular risks of fire exist

422.2.1 Wiring systems that are supplying safety circuits shall have a resistance to fire rating of 1H in absence of different regulation.

# Optional IP55 Conductor Entry and IP66 Upgrade Kit

## Technical Specifications

IP55 Conductor entry: Can be used for Switchboard and/or Power supply cover to upgrade installation to IP55 level (Dust and Water Proof).

Protect the FleXbus Conductor insulation against sharp edge from Power supply or Switchboard top cover.

- 1** Optional Heat shrink tubing to upgrade from IP55 to IP66. Thick wall polyolefin heat shrink tubing with coextruded hot melt adhesive. Shrink ratio is up to 4:1, min. shrink temperature is 135°C, operating temperature is -55°C to +130°C.
- 2** Conformable self-fusing rubber electrical insulating and sealing tape. Consists of an ethylene propylene rubber (EPR) backing coated with an aggressive, temperature-stable mastic adhesive.
- 3** Flexible PVC bellows surrounding the conductor and protecting it against sheet metal cuts. Can be adapted to any FleXbus Conductor cross section by cutting the top material with traditional cutter. Flame retardant, From -40°C to 140°C max temp, acid, solvent and UV resistant.
- 4** Rigid fiberglass-reinforced PVC flange to fix the IP55 conductor entry on the Switchboard and/or Power supply cover.
- 5** Fixing hardware (nuts and bolts)

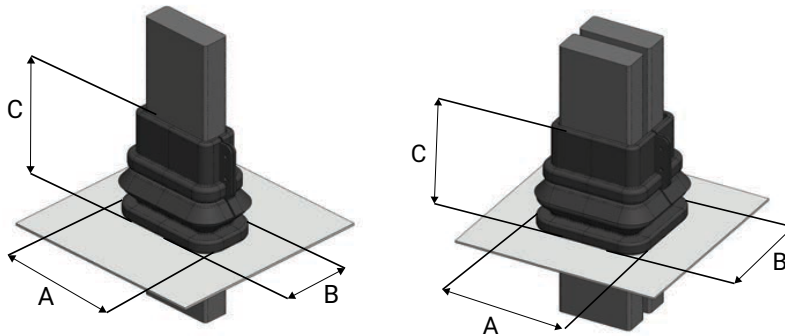
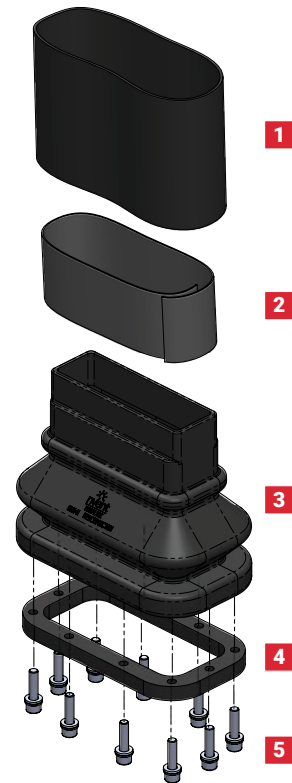

Part Number	Global Part Number	Description	A (mm)	B (mm)	C (mm)	Packing Unit	Weight (Kg)
508140	FLEXCEIP55C501	FleXbus Conductor Entry IP55 for 1 conductor 220, 360, 545 and 640 mm <sup>2</sup>	126	102	175	1 pc	0.6
508141	FLEXCEIP55C1001	FleXbus Conductor Entry IP55 for 1 conductor 960, 1280 and 1810 mm <sup>2</sup>	176	102	152	1 pc	0.7
508142	FLEXCEIP55C502	FleXbus Conductor Entry IP55 for 2 conductors 220, 360, 545 and 640 mm <sup>2</sup>	126	157	175	1 pc	0.8
508143	FLEXCEIP55C1002	FleXbus Conductor Entry IP55 for 2 conductors 960, 1280 and 1810 mm <sup>2</sup>	176	157	152	1 pc	1
508144	FLEXCEIP66C50	FleXbus Conductor Entry Optional Kit IP66 for conductor 220, 360, 545 and 640 mm <sup>2</sup>	-	-	100	1 pc	0.04
508145	FLEXCEIP66C100	FleXbus Conductor Entry Optional Kit IP66 for conductor 960, 1280 and 1810 mm <sup>2</sup>	-	-	100	1 pc	0.05



### Standard reference:

IEC 60364 Low-Voltage Electrical Installations

522.3 **Presence of water (AD) or high humidity (AB)**

522.3.1 Wiring systems shall be selected and erected so that no damage is caused by condensation or ingress of water. The completed wiring system shall comply with the IP degree of protection relevant to the particular location.

# Optional IP2x Boots

## Technical Specifications

Part Number	Global Part Number	Description	A (mm)	B (mm)	C (mm)	D (mm)	Packing Unit	Weight (Kg)
508160	FLEXCOVIP2XONE	FleXbus Transfo Cover IP2X for one Conductor per phase	465	375	126	182	1pc	0.53
508161	FLEXCOVIP2XTWO	FleXbus Transfo Cover IP2X for two Conductors per phase	670	600	180	230	1pc	0.84

IP2x boots are to be used if the power supply is not equipped with his own cover. They provide an IP2x protection (finger safe) to the LV area of the power supply. Provides protection against accidental contact with live parts > to 12 mm. IP2x Boot/cover can be adapted to any FleXbus Conductor cross section by cutting the top material with a traditional cutter and **can be adapted to any power supply palm size and height** by cutting the bottom material with a cutter. IP2x Boot is designed

to allow a 50 to 240 mm<sup>2</sup> conductor for a neutral to ground connection. **Easy and quick to install** with closing clips.

Made with high resistant and Flexible PVC, flame retardant. Working temperature From -40°C and up to 140°C. Highly resistant to acids and bases. Good resistance to solvent and hydrocarbon splashes. Good UV resistance.

Maximum voltage: 1000 VAC/1500 VDC.



Boot 508160.  
For one FleXbus  
Conductor per  
phase. Typically  
for power supply  
applications from  
400 kVA to  
1600 kVA.

Boot 508161.  
For two FleXbus  
Conductor per  
phase. Typically  
for power supply  
applications from  
2000 kVA to  
3150 kVA.

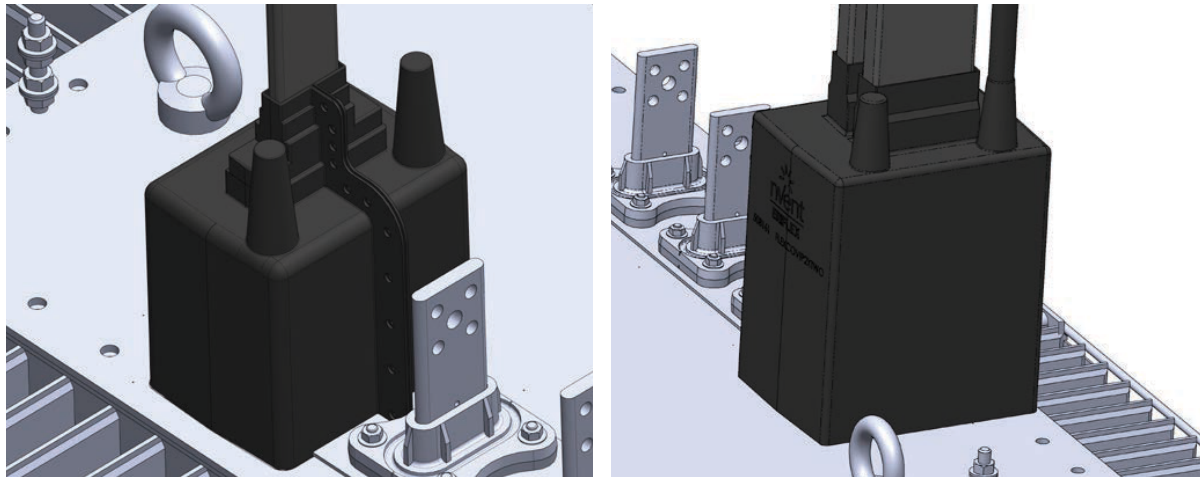

Standard reference:

IEC 60364 Low-Voltage Electrical Installations

412.2.2.3 Where lids or doors in the insulating enclosure can be opened without the use of a tool or key, all conductive parts which are accessible if the lid or door is open shall be behind an insulating barrier (providing a degree of protection not less than IPXXB or IP2X) preventing persons from coming unintentionally into contact with those conductive parts. This insulating barrier shall be removable only by use of a tool or key.

# Disposable Stripper Cutter

## Technical Specifications

- **Double-blade**, high-quality carbon steel and advanced plastic polymers.
- **Protection of the user:** risk of cut eliminated, contact of fingers with blades is impossible.
- Recessed blade reduces cut injuries and allows **stripping of the Flexbus Conductor** insulation without damaging the conductive multi-wire braid.
- Less pull force reduces hand/arm fatigue.
- Disposable.

Part Number	Global Part Number	Description	A (mm)	B (mm)	Packing Unit	Weight (Kg)
508170	FLEXSTRIPPERCUT	Flexbus Stripper Cutter for Flexbus Conductor	34	156	10 pc	0.028

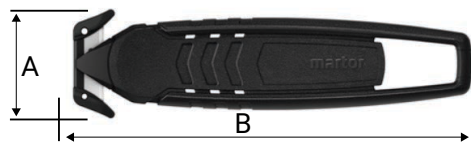

# Scissors and Shears

## Technical Specifications

- Scissors or Shears **to cut the Flexbus Conductor excess length.**
- Precision-ground, hardened blades.
- Clean and smooth cut without crushing and deformation.
- One-hand operation using ratchet principle (Scissors).
- Little hand force required due to very high transmission ratio (Scissors).
- Two-stage ratchet drive for easy cutting (Scissors).
- Simple handling as a result of low weight and compact design – can be used even in confined areas.
- Guard prevents operators' fingers from being pinched.
- High-grade special tool steel, forged, oil-hardened.

Part Number	Global Part Number	Description	A (mm)	Packing Unit	Weight (Kg)
508172	FLEXSCISSOR	Flexbus Scissors to Cut Flexbus Conductor Over length	280	1 pc	0.86
508173	FLEXSHEAR	Flexbus Shears to Cut Flexbus Conductor Over length	200	1 pc	0.324

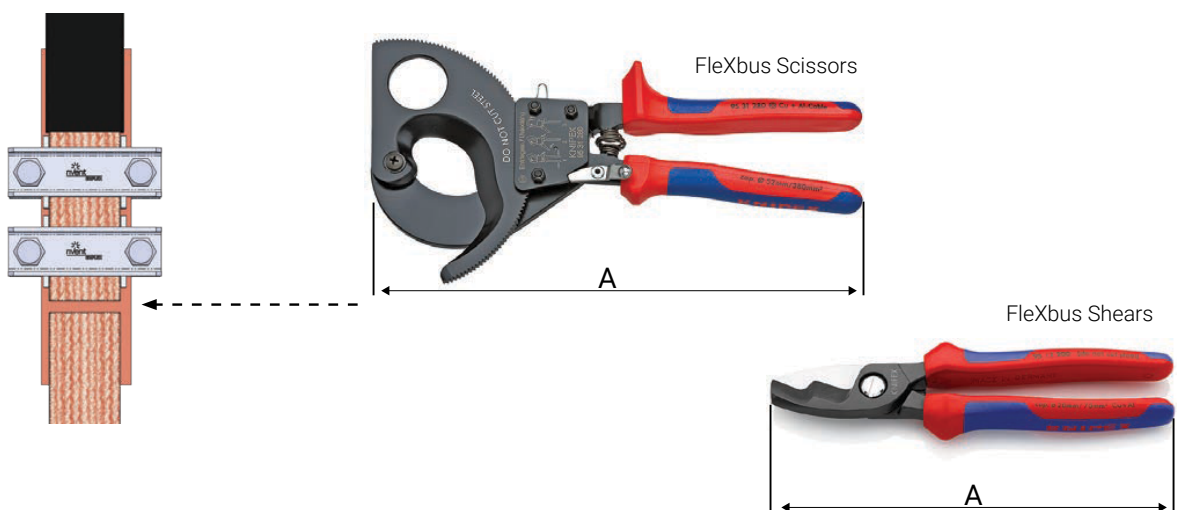

# FleXbus Aluminum Rail Cutter and Insert Crimper

## Technical Specifications



- Cuts FleXbus Aluminum Perforated Profile without burrs or deformation and chip-free
- Precise and repetitive cuts
- Cuts M6 threaded rods
- Crimps the threaded rods insert on the aluminum rail (from top or bottom)
- Can be fixed on a table or workbench or used on the floor with the supplied wooden plate
- Provided with a wooden floor plate and transportation box
- Includes ruler, guide, and end stops.
- Safe usage and conditions
- RoHS compliant

Part Number	Global Part Number	Description	L (mm)	H1 (mm)	H2 (mm)	Packing Unit (pc)	Weight (kg)
508174	FLEXALURAILCUT	FleXbus Aluminum Rail Cutter and Insert Crimper	1117	150	676	1 pc	13

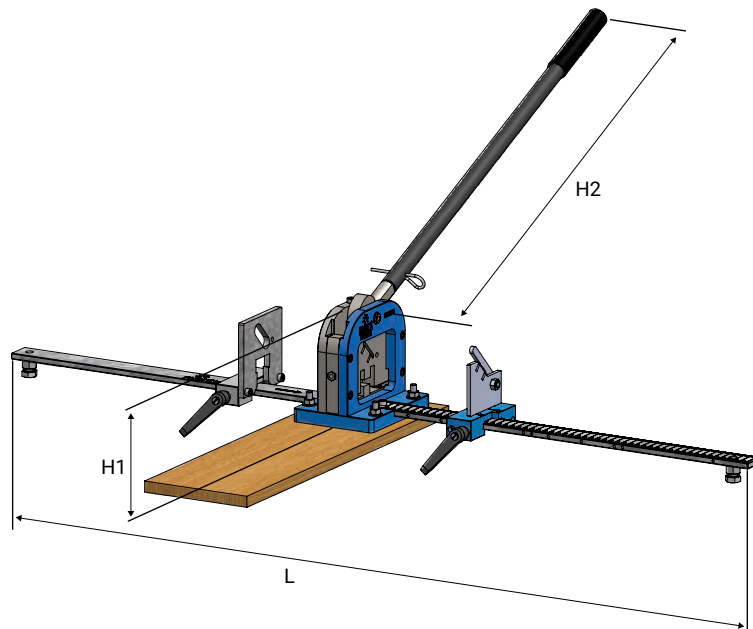

nVent.com/ERIFLEX | 101

# Identification Kit

## Technical Specifications

- Identification kit with:
  - Rubber tape L1 x 1pc
  - Rubber tape L2 x 1pc
  - Rubber tape L3 x 1pc
  - Rubber tape N x 1pc
  - FleXbus sticker 8 x 15 cm x 1pc
- Flame retardant/self-extinguishing PVC tape
- Abrasion, UV and aging resistant
- Non-corrosive adhesive
- Tape roll width: 15 mm
- Tape roll length: 10 m
- Tape thickness: 0.18 mm
- Service temperature: -5°C to +70°C
- Breaking load: 40 N/cm
- Elongation: 250%
- Breakdown voltage: 10 kV
- RoHS compliant
- Adhesion to steel: 2.3 N/cm
- Adhesion to self: 1.7 N/cm
- Specification: EN 60454 Type 6  
(Pressure-sensitive adhesive tapes for electrical purposes)

Part Number	Global Part Number	Description	Packing Unit	Weight (Kg)
508175	FLEXIDKIT	FleXbus Identification kit with L1/L2/L3/N Electrical Tape & FleXbus sticker	1 pc	0.153



# System Life Expectancy

There are many different environmental and operational conditions that are likely to influence the longevity of the Flexbus System in service.

The insulation of Flexbus Conductor may degrade over time when exposed to heat, UV light, ozone, various chemicals, excessive flexing or mechanical action, not to mention in certain situations where Flexbus may be exposed to attack by termites and rodents.

When a current passes through the Flexbus Conductor it generates heat—the higher the current, the more heat will be generated. This will have a significant impact if the conductor is undersized or continuously at or near the conductor's maximum permissible (rated) load, degrading the insulation and sheathing materials over time until they become dangerous and require replacement.

Although it is primarily the condition of the insulation and sheathing materials rather than the actual conductors that determine the longevity of the Flexbus Conductors, water ingress and poor fixings can also cause corrosion and damage.

The standards that Flexbus Conductors are manufactured to do not specify a particular life expectancy. Some cable manufacturers will determine a likely life expectancy based on typical conditions. For example, a household fixed wiring cable with typical electrical loading, wired using the appropriate wiring guidelines, could be expected to last 20 years. However, in some cases cables or conductors that have not been used excessively have been found in relatively good condition up to 50 years after installation.



## Flexbus Conductor Insulation Repair

If the Flexbus conductor insulation has been damaged during installation or afterwards, we recommend the use of 3M Scotch® 2228.

Scotch® 2228 is a conformable self-fusing rubber electrical insulating and sealing tape. Scotch® 2228 consists of an ethylene propylene rubber (EPR) backing coated with an aggressive, temperature-stable mastic adhesive. The tape is 1.65 mm thick for quick application build-up.

It is designed for electrical insulating and moisture sealing applications.



nVent.com/ERIFLEX | 103

# Periodic Check Testing of an Installation

General Information

Technical Data

Other Data



In many countries, all industrial and commercial building installations, together with installations in buildings used for public gatherings, must be retested periodically by authorized agents.

The following tests should be performed:

- Appropriate measurements for providing safety of persons against effects of electric shock and protection against damage to property against fire and heat
- Confirmation that the installation is not damaged
- Identification of installation defects

Parameters influencing the influencing aging:

- Temperature
- Vibration
- Relative humidity
- Salt environment
- UV or infrared radiation
- Dust
- Corrosive atmospheres
- Percent load
- Current harmonics

The list below shows the frequency of testing commonly prescribed according to the kind of installation concerned.

- Tightening
- Insulation between phases and between phases and live parts (like cable trays)
- Mass continuity along the system
- Complete environment agreement with the required protection range (IP)

The customer has to program inspections at regular intervals. A visual inspection every year and removing dust from the elements prior to the summer heat is recommended. After each short circuit, an inspection is absolutely necessary. Check all the connection nuts and bolts for correct torque.



# nVent ERIFLEX Flexbus Made-to-Order Solutions

In addition to our standard products presented in this catalog, our nVent ERIFLEX Engineering Team can help you define and quote a specific Flexbus configuration for your repetitive business.

Here is an example of how Flexbus can be customized according to your needs:

- 1 Flexbus Conductor with specific length in order to reduce excess length scrap.



- 2 Flexbus Conductor with specific length and crimped tube with specific drilling on both sides (ready to use).

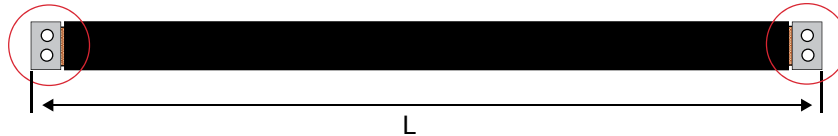

- 3 Flexbus Conductor with specific length and without termination (no crimped tube).



- 4 Extender for specific drilling and dimensions.



- 5 Complete kit creation and specific Bill of Material part number.

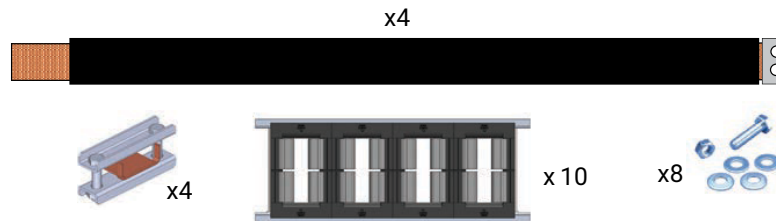

Any specific configuration will require a Minimum Order Quantity (MOQ) as explained in the table below:

Custom Solution Type	Minimum Order Quantity for Quote
1 Flexbus Conductor with specific length in order to reduce excess length scrap.	Total order of 20 pieces or 20 meters minimum of conductors, same cross section.
2 Flexbus Conductor with specific length and crimped tube with specific drilling on both sides (ready to use).	Total order of 20 pieces or 20 meters minimum of conductors, same cross section.
3 Flexbus Conductor with specific length and without termination (no crimped tube).	Total order of 20 pieces or 20 meters minimum of conductors, same cross section.
4 Extender for specific drilling and dimensions.	Four-piece minimum per order.
5 Complete kit creation and specific Bill of Material part number.	Minimum six kits per order and yearly order of 24 kits.

# FleXbus Services

nVent ERIFLEX offers the necessary products and engineering support needed to specify and build a complete range of solutions for energy, transportation, construction and applications where low voltage power storage and transmission are critical. Our engineering team brings years of experience and expertise to every project and will be with you from start to finish.



## ON-SITE SERVICES

- Installation support/assistance on end customer site
- Live training on real installation
- Theoretical and practical Installation training on your site
- Pre-installation on-site Engineering support
- Installation approval/commissioning Assistance



## DESIGN / ENGINEERING SERVICES

- 3D FleXbus Layout with Power supply/Switchboard STEP file provided + BOM + Calculation note
- Collaboration with your engineering team to find the best solution.
- Global standards compliance support and check.
- Engineering and prototype for customized product solutions

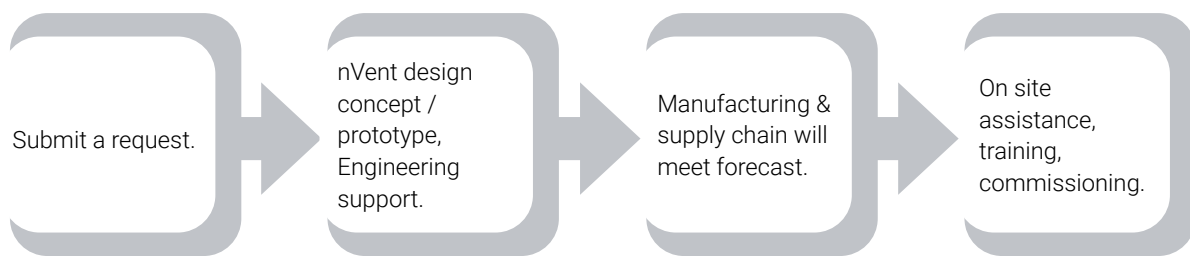
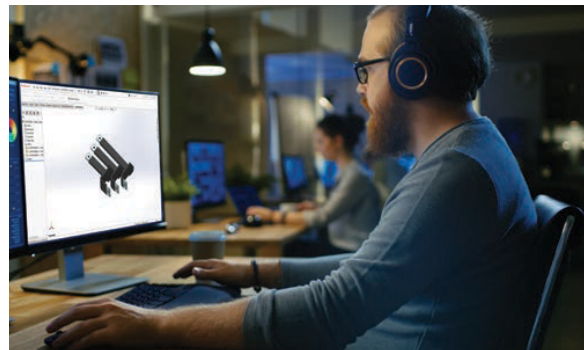

Please contact your nVent ERIFLEX representative or contact us at [ERIFLEX.FleXbus@nVent.com](mailto:ERIFLEX.FleXbus@nVent.com) for a FleXbus services quote.



The contribution of the whole electrical installation to sustainable development can be significantly improved through the design of the installation. Actually, it has been shown that an optimized design of the installation, taking into account operation conditions, MV/LV substation location and distribution structure (switchboards, busways, cables), can substantially reduce environmental impacts (raw material depletion, energy depletion, end of life), especially in terms of energy efficiency.

Besides its architecture, environmental specification of the electrical component and equipment is a fundamental step for an eco-friendly installation. In particular to ensure proper environmental information and anticipate regulation.

In Europe, several Directives concerning electrical equipments have been published, leading the worldwide move to more environmentally safe products.

- **RoHS** Directive (Restriction of Hazardous Substances): In force since July 2006 and revised on 2012. It aims to eliminate from products six hazardous substances—lead, mercury, cadmium, hexavalent chromium, polybrominated biphenyls (PBB) or polybrominated diphenyl ethers (PBDE)—from most end-user electrical products. Though electrical installations that are “large-scale fixed installations” are not in the scope, the RoHS compliance requirement may be a recommendation for a sustainable installation.

- **LSHFFR** (Low-Smoke, Halogen-Free, Flame-Retardant): The volume of power conductors and electrical devices drastically increases across industrial, commercial and residential environments. So, too, does the demand for manufacturers to choose proper electrical protection for both equipment and people. Fires that involve dangerous plastic (like PVC) can produce toxic fumes, injuring people and damaging equipment. The Flexbus System is LSHFFR to ensure proper environmental information and anticipate regulation.
- **REACH** (Registration Evaluation Authorization of Chemicals): In force since 2007, it aims to control chemical use and restrict application when necessary to reduce hazards to people and the environment. With regard to energy efficiency and installations, it implies any supplier shall, upon request, communicate to its customer the hazardous substance content in its product (so called SVHC, Substances of Very High Concern). Then, an installer should ensure that its suppliers have the appropriate information available. In other parts of the world, new legislations will follow the same objectives.

The Flexbus System has been developed and designed according to those environmental regulations.

# 3D Design of a FleXbus Pathway

To view the 3D models of our FleXbus conductors:

1. Click on the subcategory "FleXbus conductor"
2. Click on the reference of the desired part.
3. Click on the "3D Models" tab.

Follow the same steps for the other components of the FleXbus system.

You can also download the 3D model you are displaying in a variety of extensions in order to suit your preferred CAD software.

In the 3D models you will find the set of features in 3-dimensional values, as well as the straight length, and the connection range of the conductor:

- **S: minimum** - lowest threshold supported.
- **M: average** - values corresponding to a standard installation.
- **L: natural** - values of the product that causes the least effort during assembly.

Visit our website to access the 3D models of the FleXbus system. <https://www.nVent.com/en-gb/ERIFLEX/products/nVent-ERIFLEX-flexbus-system>

To create a conductor path, assemble the various lengths and features proposed in your CAD software.

Alternatively, you can download the 3D models of the FleXbus products you require by following the steps above.

Examples of 3D models provided in a FleXbus conductor file:

- Right and Left folds with S/M/L Values
- Right and Left ¼ turn twists with S/M/L Values
- Edge Bends at 15, 30 and 90° with S/M/L Values
- Straight lengths, stripped and with crimped palm

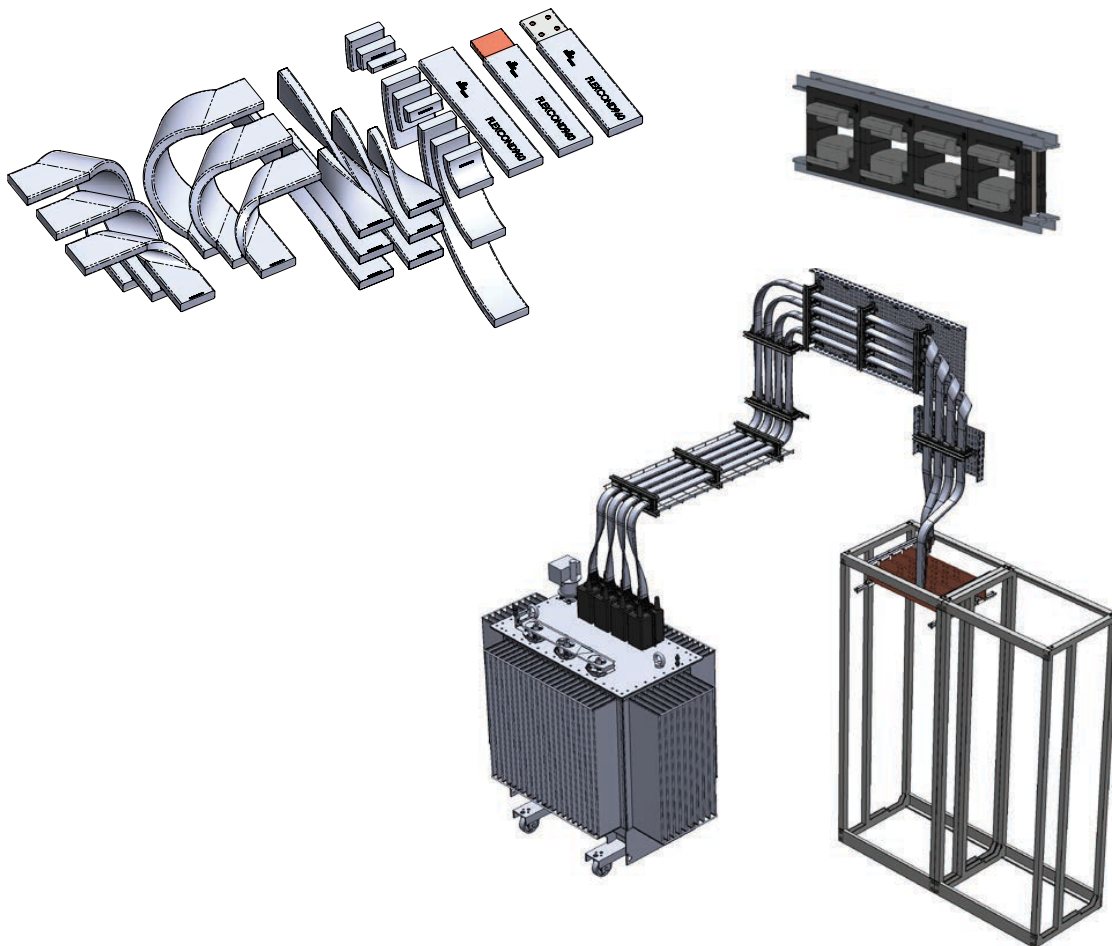

# Dedicated nVent ERIFLEX Calculation and Selection Tool Available

Our Calculation and Selection Tool is available online. Please contact your nVent ERIFLEX representative or register online.

[go.nVent.com/FleXbusConfigurator](http://go.nVent.com/FleXbusConfigurator)



This tool can determine the Bill of Material (BoM) for your configuration and provides calculation notes according to IEC 60364 Low-Voltage Electrical Installations, according to the related European Standard (HD384) and according to the National Standards like NFC 15-100, DIN VDE 0100, RGIE/AREI, CEI 64-8, BS7671, etc.

Project Information	
Customer Name	test for screenshot
Project Number/Name	test
Date	
Done by (Company)	nVent EMEA
Done by (Name)	BIZET Frederic

Circuit / Source	
Type of Circuit	Transformer
Source Name	<enter source name for display on Calculation Note>
In Source (A)	560
Voltage between phases (V)	410
Number of phases	3P
Cos φ	0.8
Harmonic	7x Pl. <-15% (Neutral not loaded)
Voltage Drop (Cos φ=0.8) (%)	0.05
Installation altitude max	2000 meters
Icc Source (kA rms)	13.8

Conductors	
Type	FlexBus Power Braid
Correction factor	1.0
Symmetrical Laying	No
Voltage	1000 VAC / 1500 VDC
Conductive part	Copper Clad Aluminum (CCA) Braid
Insulation	Thermoplastic Elastomer - 115°C max - Class II
Icw (kA)	32
Cross section per phase CPR / Euroclass	1 x 220mm <sup>2</sup> Eca - s2, d2, a3
I max / Phase (A)	666
Ambient Temperature	30°C (Usual value for installation Outside panel Air installation)
Length	Up to 2 meters
Icw > Icc Source ?	Yes
PE Copper Conductor	Not Applicable
Cross section	

Switchboard / Protecting device	
Type	Circuit Breaker
In Max (A)	0
Number of phase	3P
Time	0.2 sec
Breaking Capacity (kA)	45

According to:	
International	IEC 60364 (Low Voltage Installations)
Europe	HD 384
National	AS 3008 ONORM RGIE - AREI NBR 5410 CSN NFC 15-100 DIN VDE 0100 CEI 64-8 NEN 1010 NP REBT NIBT-NIN BS 7671

Source Name : <enter source name for display on Calculation Note>	
In Source (A) :	560
Voltage between phases (V) :	410
Icc Source (kA rms) :	13.8
Isc3 :	13.85
Isc1 :	13.52

Conductors	
Type :	FlexBus Power Braid
Cross section per phase :	1 x 220mm <sup>2</sup>
I max / Phase (A) :	666
Length :	Up to 2 meters

Isc3 :	13.49
Isc2 :	11.68
Isc1 :	12.24

Switchboard / Protecting device	
Type :	Circuit Breaker
In Max (A) :	0
Breaking capacity (kA) :	45

# Patents

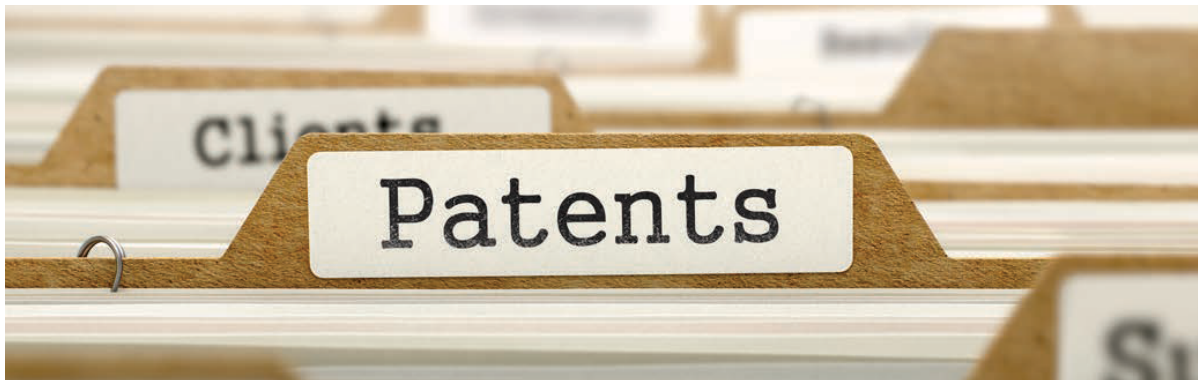

The nVent ERIFLEX FleXbus System is patented.

- Support assembly for power conductors.
  - Support Kits - Edge and Flat [\[See page 80\]](#)
- Low-voltage power conductor and system.
  - Conductor [\[See page 38\]](#)
  - HCBC Clamp and Plate [\[See page 72\]](#)
  - IP2x Boots [\[See page 99\]](#)
  - Optional Extenders [\[See page 77\]](#)

- Cable Entry System for Electrical Enclosures
  - IP55 Conductors entry [\[See page 98\]](#)

For more information regarding FleXbus System patents, please visit our website at: [nVent.com/patents](https://www.nVent.com/patents)

## Website

Our website offering possibility to:

- See all commercial and technical data
- Download the “Instructions for Use” of each FleXbus component
- Download the 3D models for design integration
- Visualize our installation videos
- Create your own PDF product datasheet

- Download our certificates and test reports
- Download our catalogs and brochures in different languages



For more information, please visit <https://www.nVent.com/en-gb/ERIFLEX>

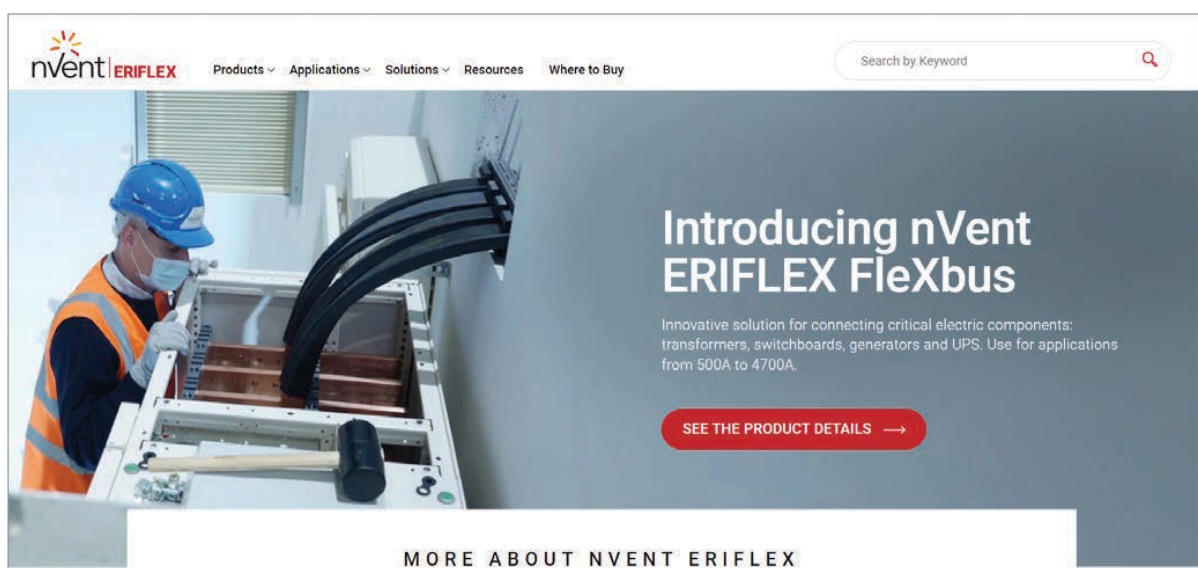

110 | [nVent.com/ERIFLEX](https://www.nVent.com/ERIFLEX)

# Application Pictures

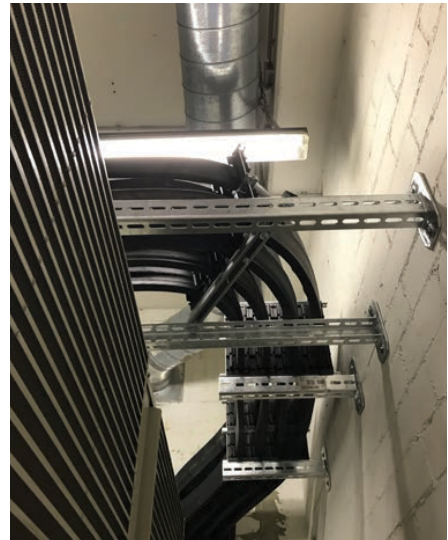
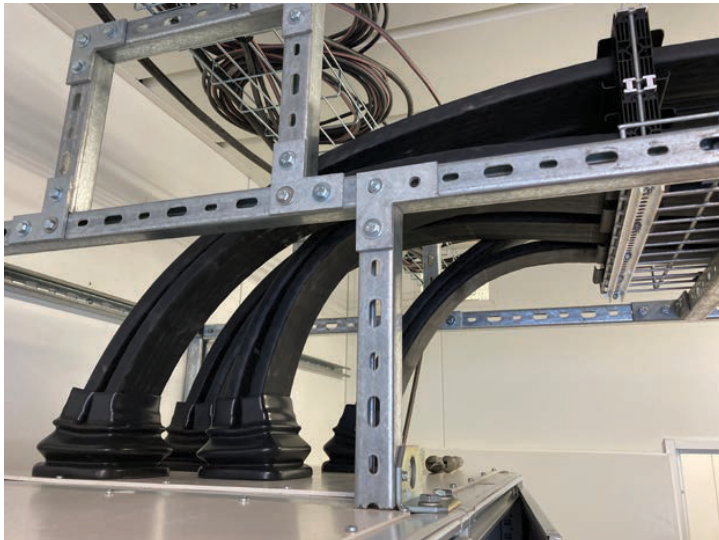

[nVent.com/ERIFLEX](http://nVent.com/ERIFLEX) | 111

General Information

Technical Data

Other Data

# Application Pictures

General Information

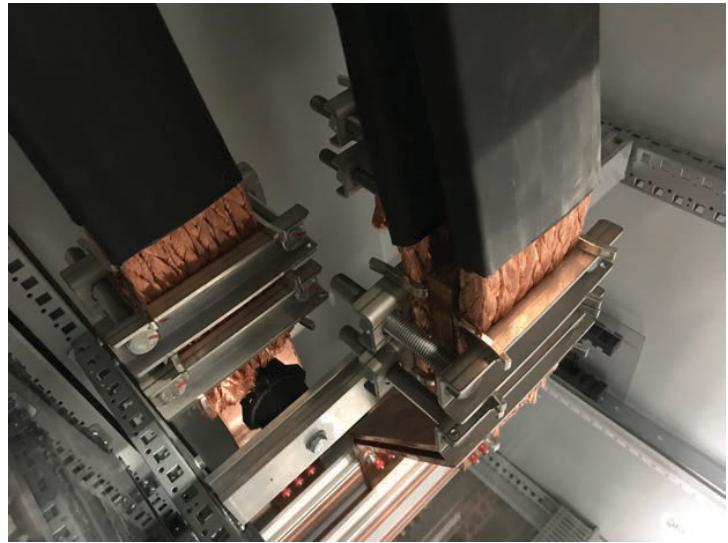

Technical Data

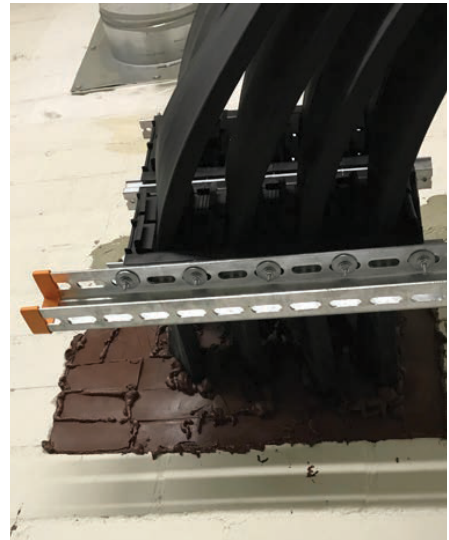

Other Data



112 | [nVent.com/ERIFLEX](http://nVent.com/ERIFLEX)



# Application Pictures

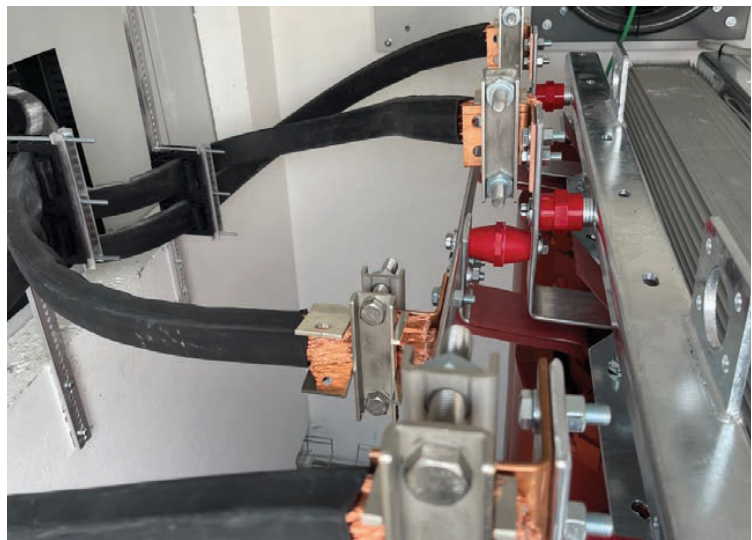
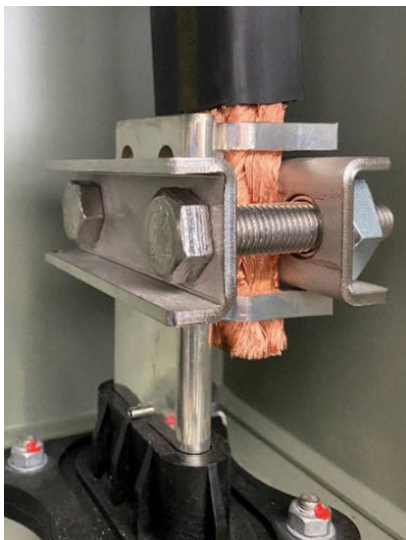
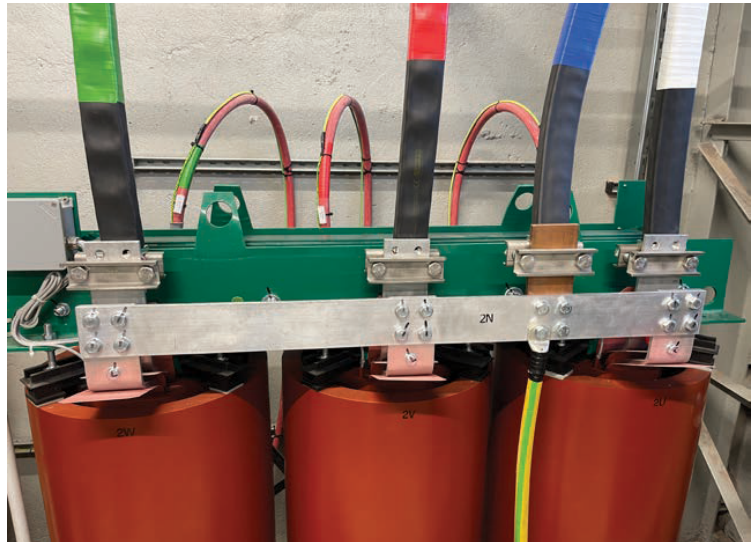

[nVent.com/ERIFLEX](http://nVent.com/ERIFLEX) | 113

General Information

Technical Data

Other Data

# Additional nVent ERIFLEX Literature

## Catalogs

General Information

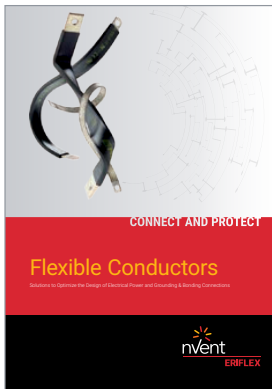

The nVent ERIFLEX Flexible Conductors catalog highlights a range of high-quality products to optimize the design of low-voltage power and ground connections for a variety of applications.



Power, earthing and grounding conductors, busbar supports and copper busbar, insulator and sleeve solutions.

Technical Data



nVent ERIFLEX hydraulic and manual tools for nVent ERIFLEX Flexibar flexible busbar and copper busbar manipulation and transformation.

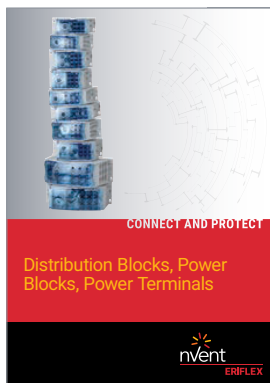

Full range of industrial connections and solutions with single- and multiple-pole distribution blocks, power terminals and power blocks.

Other Data

## Technical Guides



Technical section document for nVent ERIFLEX Flexibar product range, general characteristics, main selection criteria, calculation and installation information.



Technical section document for nVent ERIFLEX IBS and IBSB Advanced Ready-to-Use Power Conductor, general characteristics, main selection criteria, calculation and installation information.

Catalogs and Technical Guides available in local languages. Please contact your nVent ERIFLEX representative or contact us at [ERIFLEX.FleXbus@nVent.com](mailto:ERIFLEX.FleXbus@nVent.com)



Our powerful portfolio of brands:

**CADDY ERICO HOFFMAN RAYCHEM SCHROFF TRACER**



[nVent.com/ERIFLEX](https://nVent.com/ERIFLEX)

©2024 nVent. All nVent marks and logos are owned or licensed by nVent Services GmbH or its affiliates. All other trademarks are the property of their respective owners.  
nVent reserves the right to change specifications without notice.

ERIFLEX-TH-H87036-FleXbusTechnicalGuide-UKEN-2401



[heliosps.com](https://heliosps.com)

**Australia**  
[sales-au@heliosps.com](mailto:sales-au@heliosps.com)  
+61 2 7200 9200

**Asia**  
[sales@heliosps.asia](mailto:sales@heliosps.asia)  
+65 6871 4140

**New Zealand**  
[sales-nz@heliosps.com](mailto:sales-nz@heliosps.com)  
+64 9 835 0700

**Middle East**  
[sales@heliosps.asia](mailto:sales@heliosps.asia)  
+971 4 4018484