

NSR Series

500W / 750W DC UPS & Battery Charger /
500W / 750W Battery Charger & Power Supply

User Manual

Last Revision: 22 May 2026



Contents

1. Introduction	3
1.1 Purpose	3
1.2 Scope	3
1.3 UPS Features (NSRxxxUxxxx)	4
1.4 Common Features	4
1.5 Safety & Warnings	5
1.6 Abbreviation / Acronyms	5
2. Overview of the NSR Series	6
2.1 NSR Series Options	6
2.2 Common Features	7
2.3 NSRxxxUxxxx UPS / Charger Features	7
2.4 NSRxxxFxxxx Charger / PSU Features	7
2.5 NSRxxxUxxxx UPS / Charger - Rear Panel Layout	8
2.6 NSRxxxFxxxx Charger / PSU - Rear Panel Layout	9
2.7 NSR Battery Capacity Requirements	10
3. Installation & First-Run Procedure	11
3.1 Mounting	11
3.2 NSRxxxUxxxx UPS / Charger Models	12
3.3 NSRxxxFxxxx Charger / PSU Models	12
4. Troubleshooting	13
4.1 NSR LED Panels	13
4.2 NSR LED Status Tables	14
5. Programming & Monitoring	15
5.1 RS-485 MODBUS-RTU	15
5.2 Ethernet / SNMP Option (NSRxxxxxxxC)	15
6. Web Interface (NSRxxxxxxxC)	16
6.1 NSR Dashboard Login	16
6.2 NSR Dashboard Overview	17
6.3 Power Supply Configuration	18
6.4 I/O Configuration	18
6.5 Network Configuration	19
6.6 Administration Settings	20
7. Maintenance	21
7.1 Firmware Updates	21
7.2 Factory Reset Procedure	21
7.3 Fuse Replacement	22
7.4 Cooling Fan / Dust Clean Up	22



1. Introduction

The Helios NSR series consist of DC power supply and No-Break DC UPS model (NSRxxxUxxxx), and a DC power supply and battery charger model (NSRxxxFxxxx). Battery charging can be precisely controlled and optionally temperature compensated.

The NSR series come standard with RS-485 communication (MODBUS-RTU), or optional upgrade to Ethernet communication (SNMP and web interface) for remote control and monitoring of:

- Load Voltage
- Load Current
- Battery Voltage level
- Battery Current level
- Battery Temperature
- Internal Temperature
- Over Voltage Protection Status
- Overload Protection Status



1.1 Purpose

The purpose of this document is to provide a detailed description of the various functions and connections including LED indicators associated with usage of the PSU under the mode of operation.

In general, the description includes the following:

- Physical connectivity between the AC inputs and DC outputs.
- General layout of the front and rear NSR panels.
- LED indicator information.
- NSR data monitoring and alarms.

1.2 Scope

This document is intended as a guide for personnel involved in the operation of the NSR Series that is maintained by end user. The primary aspects of the NSR that this document includes are listed as follows:

- Connection to V AC inputs.
- Connection from V DC outputs.
- Operations of the LED indicators.
- Connection to the Ethernet Port/RS 485 for data monitoring and alarm monitoring.
- Troubleshooting and maintenance.

The NSR is a power supply system, and it has no capability to display the logger data and therefore any system logging specific data presented for display is beyond the scope of this document.

1.3 UPS Features (NSRxxxUxxxx)

In the event of a mains outage (UPS mode), the NSR will not be interrupted and will continue to deliver power up to 150% of the rated current until low voltage disconnect (LVD).

In the event of a mains outage (UPS mode) and when mains AC returns, there will be a small delay before the charger returns to charging mode and gradually increases the current up to the charge current limit or available current.

The battery will not be recognised if its level is below the detection threshold. In this case, the NSR will remain in power supply mode. This will ensure that it does not draw the load output voltage too low, which could affect the connected load.

If the battery is connected to the battery terminals, the charger will switch to float charging mode, and the output voltage will be set to the user-defined float voltage plus the charge current limit function (e.g., 27.8V at 10A). The user can also change the charge current limit.

If the battery is disconnected, a battery current detection function will check if no current is flowing (less than 200mA) and will monitor the no-battery voltage at 1.4 times the battery cell voltage. If no current flows within 5 seconds and the battery voltage is less than 1.4 times the battery cell voltage, the system will return to power supply mode (PSU mode voltage).

Low Voltage Disconnect (LVD)

The LVD is triggered when the battery voltage falls below the user-set LVD threshold. There is a 30-second delay before disconnection. The timer delay will reset if the battery voltage rises to LVD threshold +0.5 volts. In the event of LVD activation, the NSR will enter low power mode, turning off the output and waiting for the mains AC to return.

In the event of an overload or overvoltage, the system will enter standby mode, turning off the output. To clear the alarms, press the standby switch on the front panel or control it from a web browser. This ensures that users are alerted to what is happening with the unit itself.

Battery Condition Test (BCT) Operation

The BCT can be started or stopped manually, or it can operate automatically (the default setting is manual). In the event of a BCT operation failure, the BCT alarm flag will remain active until the next operation passes or the system is reset.

1.4 Common Features

NSR units can operate between -10°C to +50°C, and can charge the batteries between these temperature ranges.

NSR units can charge Li-Ion/LiFePO4 and lead acid batteries. Please check the battery compatibility table on page 10 of this manual for appropriate battery / battery bank types and capacities.

The low battery voltage alarm is triggered if the voltage falls below the user-set low voltage threshold. The alarm is cleared when the battery voltage exceeds the battery detection level.

If no battery is connected when the NSR is powered up, the output voltage will be the nominal rated voltage, e.g., 24V (power supply mode voltage) programmed for UPS models, or the programmed float voltage for charger models.

NOTICE

THIS IS NOT AN EV CHARGER, IT CAN NOT BE USED TO CHARGE ELECTRIC VEHICLES. WHEN BATTERY VOLTAGE REACHES ITS CHARGING VOLTAGE THE NSR WILL SWITCH TO TRICKLE CHARGE

1.5 Safety & Warnings

Safety

The user is responsible for ensuring that input and output wiring segregation complies with local standards and that in the use of the equipment, access is confined to operators and service personnel.

A low resistance earth connection is essential to ensure safety and additionally, satisfactory EMI suppression (see below).

Electrical Strength Tests

Components within the power supply responsible for providing the safety barrier between input and output are constructed to provide electrical isolation as required by the relevant standard. However EMI filtering components could be damaged as result of excessively long and high voltage tests between input, output and ground. Please contact our technicians for advice regarding electric strength tests.

Earth Leakage

Where fitted, EMI suppression circuits cause earth leakage currents which may be to a maximum of 3.5mA.

Ventilation

High operating temperature is a major cause of power supply failures, for example, a 10°C rise in the operating temperature of a component above rated temperatures will halve its expected life. Therefore always ensure that there is adequate ventilation for the equipment. Batteries in particular suffer shortened lifetimes if subjected to high ambient temperatures.

Water / Dust Ingress

Every effort must be made in the installation to minimise the risk of ingress of water or dust. Water will almost always cause instant failure. The effects of dust are slower in causing failure of electronic equipment but all electrical equipment should be cleaned free of any dust accumulation at regular intervals.

Electromagnetic Interference (EMI)

Switching power supplies and converters inherently generate electrical noise. All wiring should be as short as practicable and segregated from all equipment wiring which is sensitive to EMI. Residual noise can be reduced by looping DC wiring through ferrite cores (sleeves). These are most effective as close to the power supply as possible and as many turns of the wire taken through the core (+ and - in the same direction) as the core will accommodate.

External Fuse Protection

Fuses or circuit breakers must be used in all battery circuits to protect against short circuits. External fuses should be used for power supplies / chargers even though they are usually internally protected.

Connection Polarity

It is critical to check the polarity carefully when connecting DC loads and batteries even with models which have non-destructive reverse polarity protection.

Warnings

- This power supply is NOT intended for use by persons (including children) with reduced physical, sensory or mental capabilities or lack of experience and knowledge, unless they have been given supervision or instruction concerning the use of the power supply by the person responsible for their safety. Children should be supervised to ensure they do not play with the power supply.
- The NSR is for Indoor Use Only
- Follow this manual before charging battery.
- Disconnect the AC input before connecting or disconnecting the battery and/or load.
- Explosive gases. Prevent flames & sparks and provide adequate ventilation during charging.
- The marking on the power supply, "+" is a positive polarity and "-" is a negative polarity.
- When charging batteries, ensure they are the same type, same voltage and same capacity rating
- During the charging cycle ensure the batteries are in a well-ventilated area.
- DO NOT attempt to charge non-rechargeable batteries. It may lead to explosion of batteries or fire.

1.6 Abbreviation / Acronyms

AC	Alternating Current
DC	Direct Current
DOD	Depth Of Discharge
BCT	Battery Condition Test
ECB	Electronic Circuit Breaker
ELVD	Electronics Low Voltage Disconnection
EMI	Electromagnetic Interference
LAN	Local Area Network
LED	Light Emitting Diode
LVD	Low Voltage Disconnect
PSU	Power Supply Unit
RPP	Reverse Polarity Protection
SNMP	Simple Network Management Protocol
Vac	Voltage - Alternating Current
Vdc	Voltage - Direct Current

2. Overview of the NSR Series

2.1 NSR Series Options

The NSR series are available in two distinct types.

NSRxxxUxxxx
No-Break DC UPS with
Programmable Battery Charger / DC Power Supply

Designed to provide uninterrupted DC power to the connected load automatically, using mains (AC) or battery (DC) power. Battery charging is automatically managed when mains power is available, and a low voltage disconnect will prevent the batteries from over-discharge when in UPS mode.

NSRxxxFxxxx
Programmable Battery Charger /
Precision DC Power Supply

Designed to provide precision battery charging, or for use as a precision AC to DC power supply when no battery connected.

Base Model	Output Power (W)	Operation Mode	Battery Nom. Voltage	Output Terminals	Communications
NSR	100	U F	12	S T	(blank) C
	250		24		
	500		48		
	750				

Output Power (W)	Operation Mode	Battery Nom. Voltage	Output Terminals	Communications
100 - 100W 250 - 250W 500 - 500W 750 - 750W	U - UPS/Charger F - Charger/PSU	12 - 12Vdc 24 - 24Vdc 48 - 48Vdc	S - M8 Studs T - Phoenix Terminals*	(blank) - RS-485 C - Ethernet/SNMP

Example: NSR750U12SC
750W DC UPS, 12Vdc Nominal Battery Voltage with Stud Terminals and Ethernet/SNMP

* Note: NSR750x12 and NSR500x12 are only available with stud terminals due to high DC current.

NOTICE

PLEASE CAREFULLY CHECK THE RATING LABEL OF YOUR NSR TO CONFIRM RATED VOLTAGE AND MODEL CAPABILITIES PRIOR TO INSTALLATION

THE BATTERY / BATTERIES CONNECTED TO THE NSR MUST MATCH THE NOMINAL VOLTAGE OF THE NSR

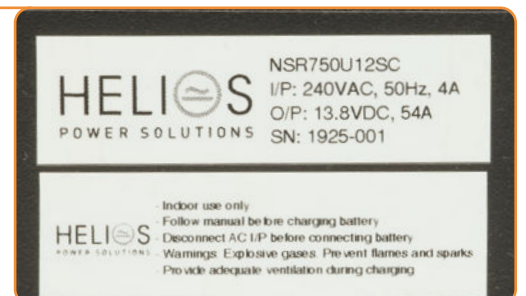

2.2 Common Features

- Precision battery charger compatible with Li-ion, LiFePO4, and Lead Acid battery chemistries.
- Temperature compensation of battery charge voltage to lengthen battery life.
- Monitoring of the battery status and availability at all times.
- Monitoring of mains input power status.
- Continuous monitoring of power supply voltage, battery voltage on mains failure (UPS models only), power supply and battery currents.
- Monitoring of battery surface or battery terminal temperature (depending on location of temp. sensor).
- Alarm contacts to enable interfacing with monitoring equipment such as PLCs, SCADA, security, telemetry.
- Adjustable battery charge current limit.
- Monitoring of power supply and network settings.
- RS-485 MODBUS-RTU compatible communications for monitoring and control.
- Ethernet / SNMP monitoring and programming (NSRxxxxxxxC models), with SNMP traps available for user data logging.

2.3 NSRxxxUxxxx UPS / Charger Features

In addition to the common features available on all NSR models, the UPS version includes the following additional features:

- No-break switching of power to connected load from mains to battery, on mains power failure.
- Battery condition test (BCT) at preset intervals or as determined by the user to determine battery voltage.
- Deep discharge protection by disconnecting the load at low battery voltage.
- Battery overcurrent protection and reverse polarity connection, using an electronic circuit breaker (ECB). With input (mains) power present, the ECB acts to limit the battery current but does not latch open. If no mains power is present then the ECB will latch open on battery circuit overcurrent.

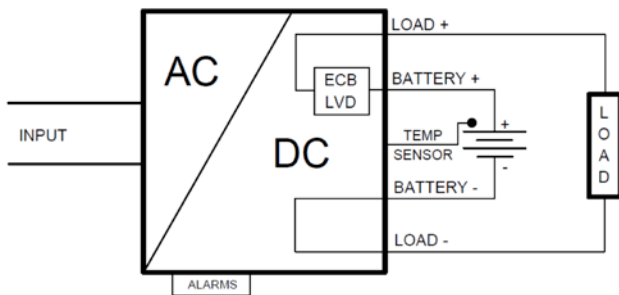

Figure 1. NSRxxxUxxxx Block Diagram

2.4 NSRxxxFxxxx Charger / PSU Features

In addition to the common features available on all NSR models, this version can also be used as a precision DC power supply.

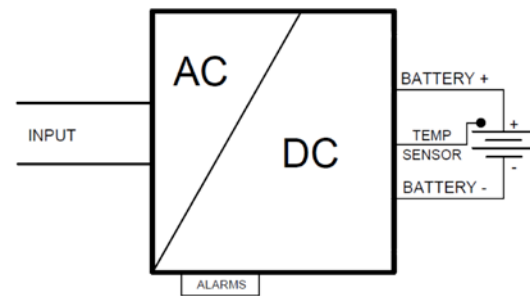

Figure 2. NSRxxxFxxxx Block Diagram

WARNING

TAKE CARE WITH POLARITY OF ALL CONNECTIONS. IF THE BATTERY IS CONNECTED IN REVERSE POLARITY, THE INTERNAL PROTECTION FUSE WILL BE RUPTURED ALONG WITH OTHER POSSIBLE DAMAGE AND THE UNIT SHOULD BE RETURNED TO THE MANUFACTURER FOR REPAIR.

2.5 NSRxxxUxxxx UPS / Battery Charger Rear Panel Layout

NSRxxxUxxSx Models

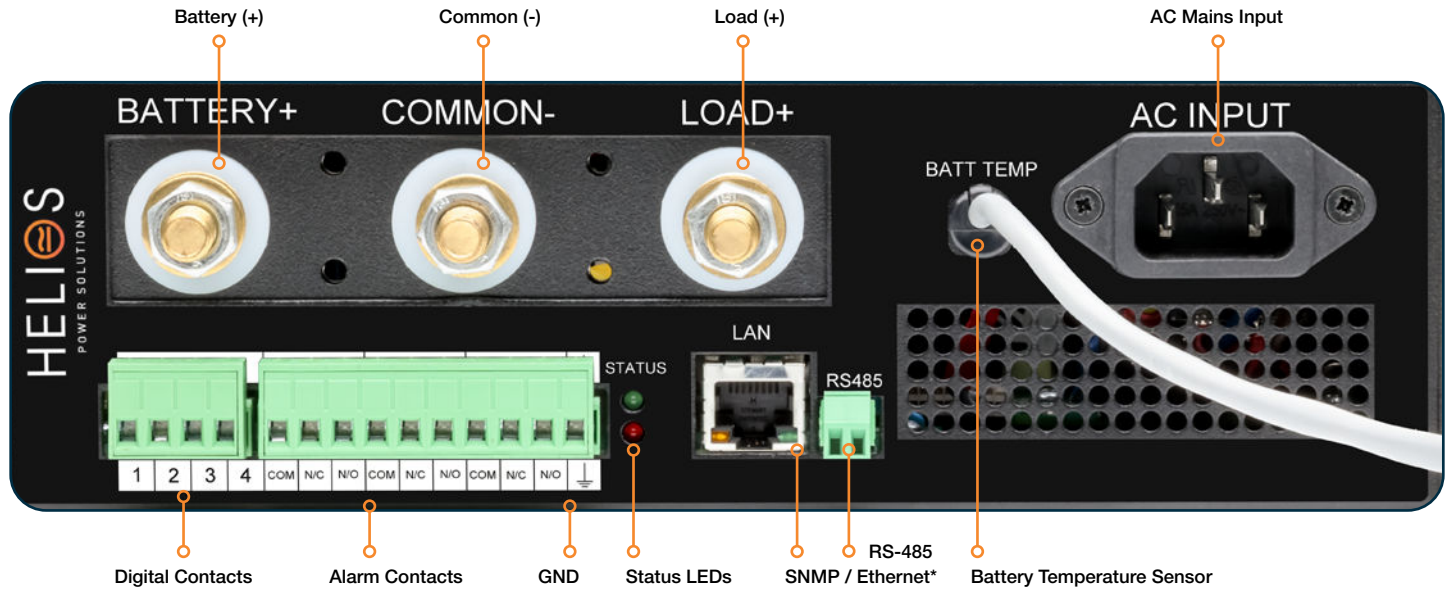

NSRxxxUxxTx Models

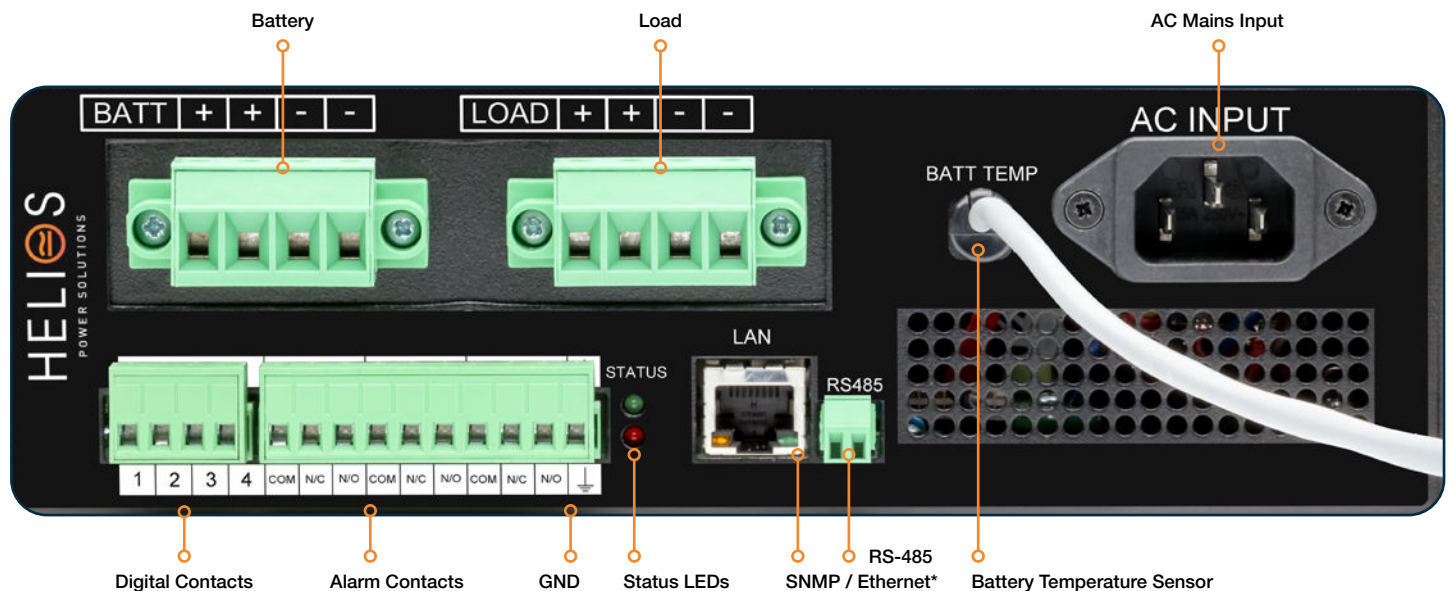

* Optional

2.6 NSRxxxFxxxx Battery Charger / Power Supply - Rear Panel Layout

NSRxxxFxxSx Models

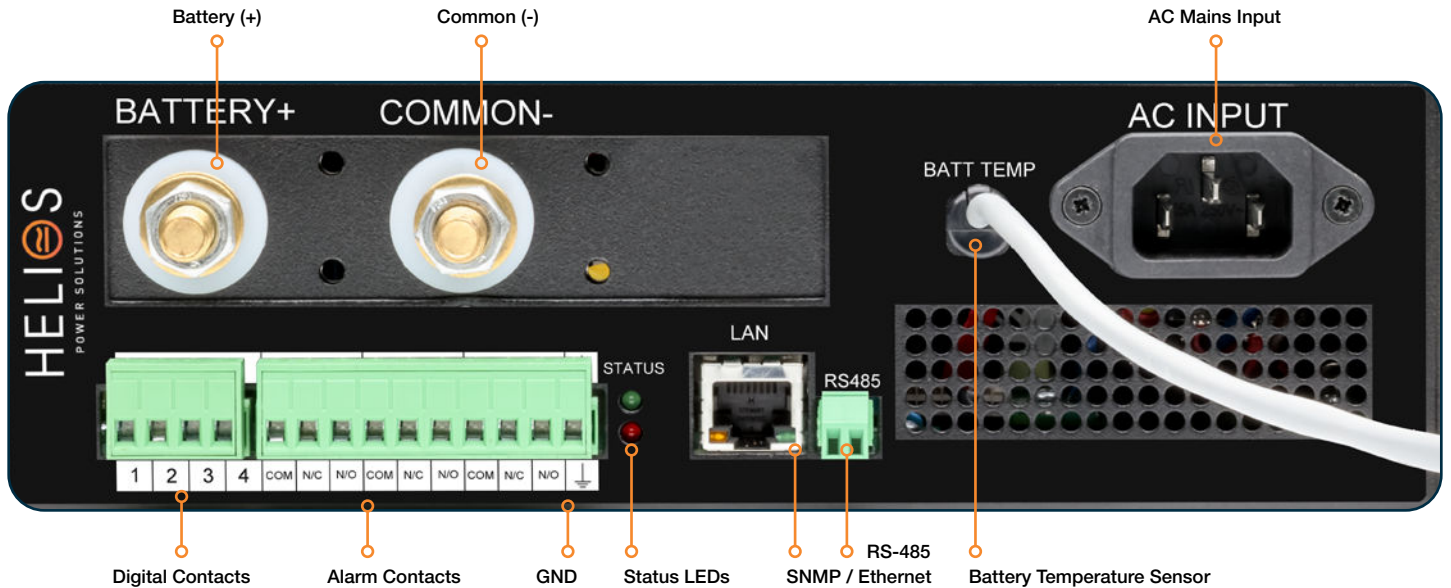

NSRxxxFxxTx Models

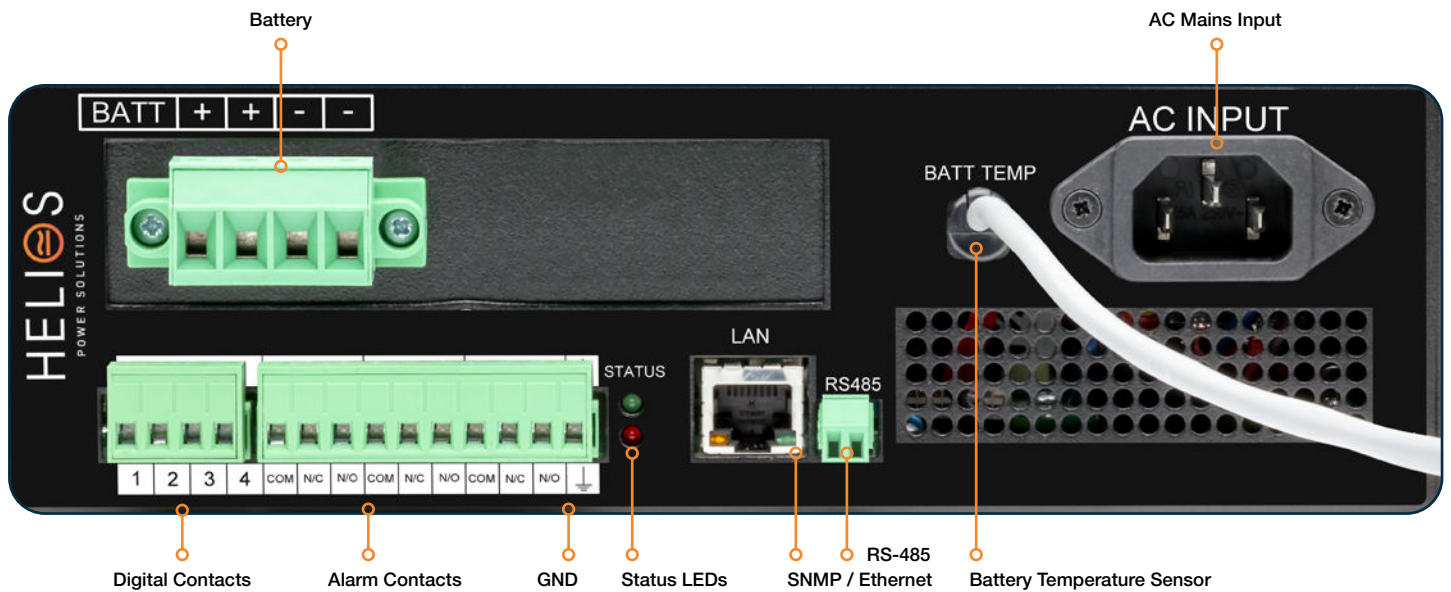

* Optional

2.6 NSR Battery Capacity Requirements

The following battery capacities are recommended for your NSR model.

Matching battery capacity to your NSR model is important to ensure the battery is not over or undercharged.

NSR Model	Min Battery Capacity (Ah)	Max Battery Capacity (Ah)
NSR500x12 - 500W/12V	130Ah	600Ah
NSR500x24 - 500W/24V	65Ah	300Ah
NSR500x48 - 500W/48V	30Ah	150Ah
NSR750x12 - 750W/12V	200Ah	900Ah
NSR750x24 - 750W/24V	100Ah	450Ah
NSR750x48 - 750W/48V	50Ah	220Ah

CAUTION

FAILURE TO SELECT A SUITABLE BATTERY COULD CAUSE OVER-CHARGING AND OVER-HEATING OF THE BATTERY, CAUSING PERMANENT DAMAGE OR FIRE.

ALWAYS ENSURE THE BATTERY'S NOMINAL VOLTAGE MATCHES YOUR NSR MODEL, AND CAPACITY FALLS WITHIN THE RECOMMENDED RANGES.

3. Installation & First-Run Procedure

3.1 Mounting

Bulkhead Brackets

Your NSR is shipped with two bulkhead mounting brackets and a set of 8 M3 x 4mm screws, to allow secure installation. Install the brackets (if desired) as follows:

1. Turn over your NSR to easily access the base of the chassis.
2. Align the brackets to the threaded holes on the base of the NSR.
3. Using hand tools only, fasten each bracket with 4 of the supplied screws.
4. Ensure the screws are firm but do not overtighten.

You can now mount the NSR to your required location.

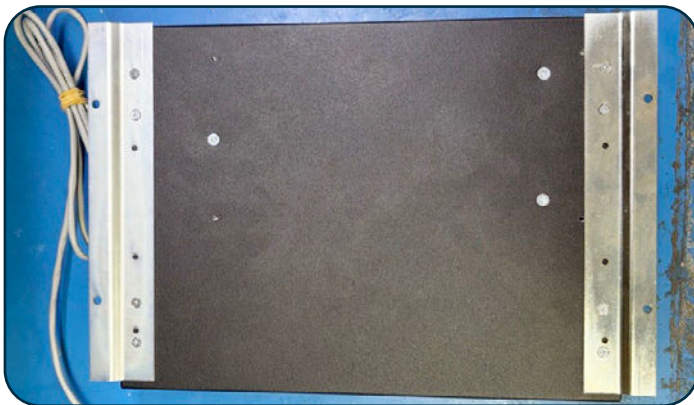

Surface Mounting

You can mount your NSR directly to a surface of your choosing. Refer to the hole spacing diagram below.

Use M3 screws to mount the NSR, ensuring protrusion depth does not exceed 3mm into the NSR, or permanent damage may occur.

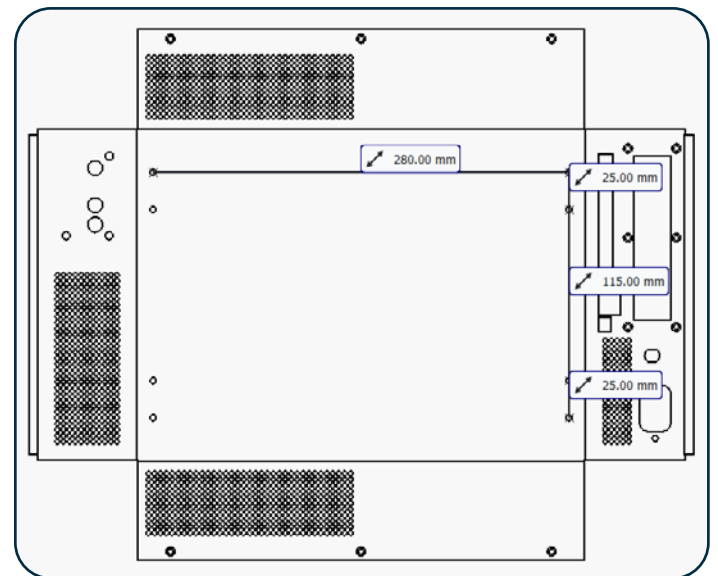

WARNING

USE ONLY THE SUPPLIED M3 X 4MM COUNTERSUNK SCREWS TO SECURE MOUNTING BRACKETS TO NSR CHASSIS. THE USE OF INCORRECT SCREWS MAY PERMANENTLY DAMAGE THE NSR AND VOID WARRANTY.

WARNING

USE HAND TOOLS ONLY - DO NOT OVERTIGHTEN OR PERMANENT DAMAGE TO THE MOUNTING THREADS MAY OCCUR.



3.2 NSRxxxUxxxx UPS / Charger Models

Complete the following process before powering on your NSR:

1. Check input and output voltages of system, ensure that they match your AC power source, and the connected batteries and / or loads. All loads should be isolated.
2. Inspect the AC power cord for any corrosion or damage. If corroded or damaged, it must be replaced.
3. Plug in AC input and turn power on.
4. Both front-panel LEDs will light up after approx. 4 sec, "BATTERY SYS OK" LED will go out after another 10 sec. DC output voltage should appear on load output.
5. Turn off input power and wait 10 seconds, confirming that all LEDs on the NSR are off.
6. Connect your batteries and load, paying careful attention to the polarity of all wiring.
 - a. For Studs
Connect battery to Common (-) and Battery (+) terminals, and load to Common (-) and Load (+) and tighten M8 nuts.
 - b. For Phoenix Connectors
Connect battery and load to the plugs of the Phoenix connectors paying careful attention to polarity, and tighten terminal blocks. Insert into respective Phoenix sockets, ensuring connectors are fully seated.
7. Place temperature sensor probe on the batteries or ideally on the battery terminals.
8. Optionally connect the RS-485 and/or RJ45 LAN port to the Ethernet network (where fitted).
9. Turn on AC power to power up the NSR.
10. Confirm status LEDs with the System Status table, and/or via external monitoring.
11. After the batteries are fully charged, switch off AC input power and check that the battery continues to power the load. Once confirmed, ensure AC power is switched back on.

3.3 NSRxxxFxxxx Charger / PSU Models

Complete the following process before powering on your NSR:

1. Check input and output voltages of system, ensure that they match your AC power source, and the connected batteries and / or loads. All loads should be isolated.
2. Inspect the AC power cord for any corrosion or damage. If corroded or damaged, it must be replaced.
3. Plug in AC input and turn power on.
4. Both front-panel LEDs will light up after approx. 4 sec, "BATTERY SYS OK" LED will go out after another 10 sec. DC output voltage should appear at battery output.
5. Turn off input power and wait 10 seconds, confirming that all LEDs on the NSR are off.
6. Connect your batteries paying careful attention to the polarity of all wiring.
 - a. For Studs
Connect battery or load to Common (-) and Battery (+) terminals, and tighten M8 nuts.
 - b. For Phoenix Connectors
Connect battery or load to the plug of the Phoenix connectors paying careful attention to polarity, and tighten terminal blocks. Insert into Phoenix socket, ensuring connectors are fully seated.
7. Place temperature sensor probe on the batteries or ideally on the battery terminals (when using as a battery charger).
8. Optionally connect the RS-485 and/or RJ45 LAN port to the Ethernet network (where fitted).
9. Turn on AC power to power up the NSR.
10. Confirm status LEDs with the System Status table, and/or via external monitoring.

WARNING

ALL WIRING BETWEEN BATTERIES AND NSR MUST BE INDEPENDENTLY FUSED. FAILURE TO DO SO MAY CAUSE FIRE OR EXPLOSION OF BATTERIES UNDER SHORT CIRCUIT CONDITIONS.

CAUTION

REVERSE POLARITY CONNECTION OF BATTERY IF THE BATTERY IS CONNECTED IN REVERSE, THE INTERNAL BATTERY PROTECTION FUSE WILL BE RUPTURED ALONG WITH OTHER POSSIBLE DAMAGE AND THE UNIT SHOULD BE RETURNED TO THE MANUFACTURER FOR REPAIR.



4. Troubleshooting

Use the following tables to resolve minor issues with the NSR.

4.1 NSR LED Panels

Regardless of the model being used, the NSR series all have common:

- Front panel LEDs
- Rear panel LEDs and
- Rear Input/Output relays for external monitoring purposes.

The front panel LEDs consist of:

Battery System OK indication

LED ON represents the battery is present and the battery voltage is above the configured (configurable threshold).
LED OFF represents no battery detected or battery voltage is below the configured threshold.

Note: For float models operating in power supply mode, a connected load will also cause the Battery OK LED to illuminate.

Mains Power OK indication

LED ON represent the mains input power is present,
LED OFF represents the no mains input power or the system is in STANDBY mode

Standby Indication and Operation

LED ON represents the system is in STANDBY mode,
LED OFF represents the system in normal operation

The rear panel LEDs consist of:

- Red LED
- Green LED

These LEDs are mainly used as the system status indicators with the exception of the standby LED, when this LED is pushed briefly it will put the system into standby mode.

The combination of LED status and the output relays represent a certain/unique condition or fault of the system.

Follow the tables on the following page to troubleshoot or diagnose a fault detected with the NSR system.

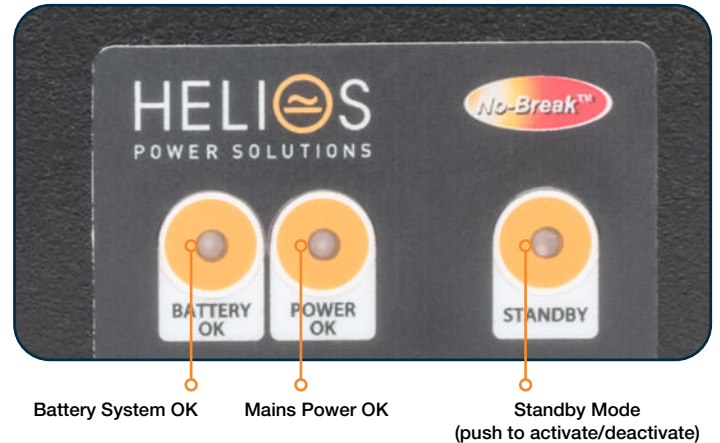

NSR Front Panel LEDs

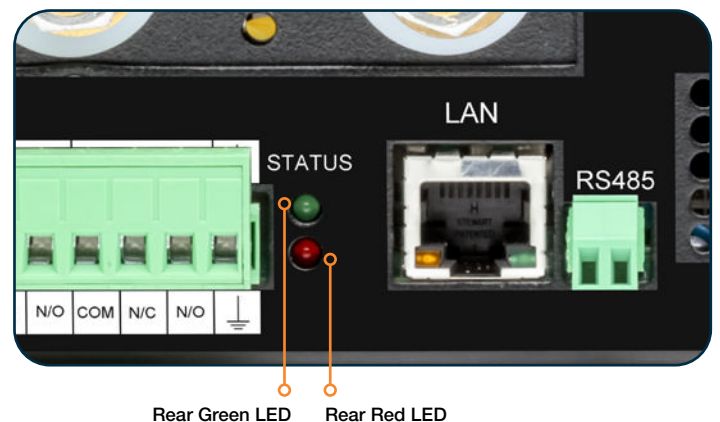

NSR Rear Panel LEDs

4.2 NSR LED Status Tables

Use the following tables to identify and resolve minor operational issues with the NSR.

NSRxxxUxxxx UPS / Battery Charger - System Status

Front LEDs			Rear LEDs		Relay			Condition
Battery OK	Power OK	Standby	Green	Red	AUX	Power	Battery	
☀	☀	○	☀	○	Off	On	On	System Normal: Input power on, battery circuit OK
☀	☀	○	☀	☀	Off	On	Off	Battery failed BCT, AC input and DC output is OK
○	☀	○	☀	☀	Off	On	Off	Input power on, battery system fault. 1. Internal battery fuse has opened or 2. Battery circuit wiring open circuit / battery missing
☀	○	○	☀	○	Off	Off	On	AC mains fail, battery >= batt low voltage threshold
☀	○	○	○	☀	Off	Off	Off	AC mains fail, battery < batt low voltage threshold
○	○	○	○	○	Off	Off	Off	AC mains fail & battery disconnected. NSR is completely OFF
☀	☀	○	☀	○	On	On	On	BCT is in progress (AC mains OK, battery system OK)
☀	☀	☀	☀	○	Off	On	On	NSR in standby, input power on, battery system OK
○	☀	☀	☀	☀	Off	On	Off	NSR in standby, input power on, battery missing
☀	○	☀	☀	○	Off	Off	On	NSR in standby, AC mains fail, battery system OK
☀	○	☀	○	☀	Off	Off	Off	NSR in standby, AC mains fail, battery < batt low voltage threshold
☀	☀	☀	☀	○	Off	On	On	Fan Fail (AC mains OK, battery system OK)
○	☀	☀	○	☀	-	-	-	Over-voltage - load input or battery input (130% of nominal rating)*
☀	○	☀	○	☀	-	-	On	Overload / short circuit*

Legend: ☀ LED On ☀ LED Flashing ○ LED Off

NSRxxxFxxxx Battery Charger / Power Supply - System Status

Front LEDs			Rear LEDs		Relay			Condition
Battery OK	Power OK	Standby	Green	Red	AUX	Power	Battery	
☀	☀	○	☀	○	On	On	On	System Normal: Input power on, battery circuit OK
○	☀	○	☀	☀	On	On	Off	Input power on, internal battery fuse has opened
☀	○	○	☀	○	On	Off	On	AC mains fail, battery >= batt low voltage threshold
☀	○	○	○	☀	On	Off	Off	AC mains fail, battery < batt low voltage threshold
○	○	○	○	○	On	Off	Off	AC mains fail & battery disconnected. NSR is completely OFF
○	☀	☀	☀	☀	On	On	Off	NSR in standby, input power on
☀	○	☀	○	☀	On	Off	Off	NSR in standby, AC mains fail, battery < batt low voltage threshold
☀	☀	☀	☀	☀	On	On	On	Fan Fail (AC mains OK, battery system OK)
○	☀	☀	○	☀	-	-	-	Over-voltage - load input or battery input (130% of nominal rating)*
☀	○	☀	○	☀	On	-	On	Overload / short circuit*

Legend: ☀ LED On ☀ LED Flashing ○ LED Off

5. Programming & Monitoring

5.1 RS-485 MODBUS-RTU

RS-485 MODBUS-RTU is available on all NSR models.
For the full RS-485 register table, contact your sales engineer.

Modbus Protocol Specification

Physical Interface: RS-485
Protocol Type: Modbus RTU

Default Settings

Baud Rate: 9600
Parity: None
Data Bits: 8
Stop Bits: 1
Default Device ID: 1

Supported Modbus Function Codes

- 0x03 Read Holding Registers
- 0x06 Write Single Register
- 0x10 Write Multiple Registers

Modbus RS-485 Pinout

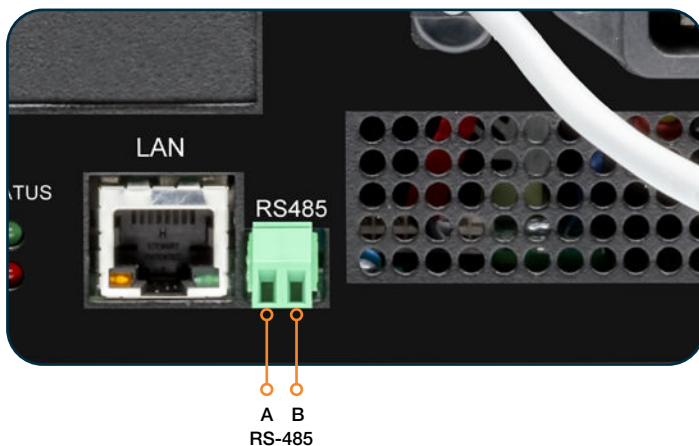

5.2 Ethernet / SNMP Option (NSRxxxxxxxC)

This is an Ethernet Port for remote monitoring or diagnostic port of the PSU voltages and internal alarms. It is currently configured to monitor,

- Vac input status
- Charger Vdc status
- Battery status
- Load status (for UPS models)
- Internal alarms

The ethernet interface comes with a default network configuration below:

Network IP: 10.10.10.10
Netmask: 255.255.255.0
Username: admin
Password: 1234
Default HTTP port is 80

You can connect directly to this RJ45 interface using a standard Cat5e (or better) cable directly between the management computer and the NSR. Alternatively you can connect the NSR to your LAN network via a switch.

CAUTION

CARE MUST BE TAKEN WHEN MAKING CONFIGURATION CHANGES TO THE NETWORK SETTINGS. AN ERROR IN CONFIGURATION COULD MAKE THE NSR UNREACHABLE.

6. Web Interface (NSRxxxxxxxC)

The NSRxxxxxxxC comes with an internal web interface for monitoring and configuration purposes, in addition to the standard RS-485 found on all NSR units.

6.1 NSR Dashboard Login

Before connecting a computer to the NSR's RJ45 port, please ensure the IP address of your computer has the same subnet and netmask as the NSR. You can then access the web interface at:

http://10.10.10.10

Note: SSL / HTTPS will be available on NSR units with future firmware releases.

Once connected to the NSR, from the computer, launch your web browser and type in the browser's address bar the PSU default network address above. Upon a successful connection, the system will prompt for login credential.

Enter the correct default username and password, and the NSR web interface will display the dashboard.

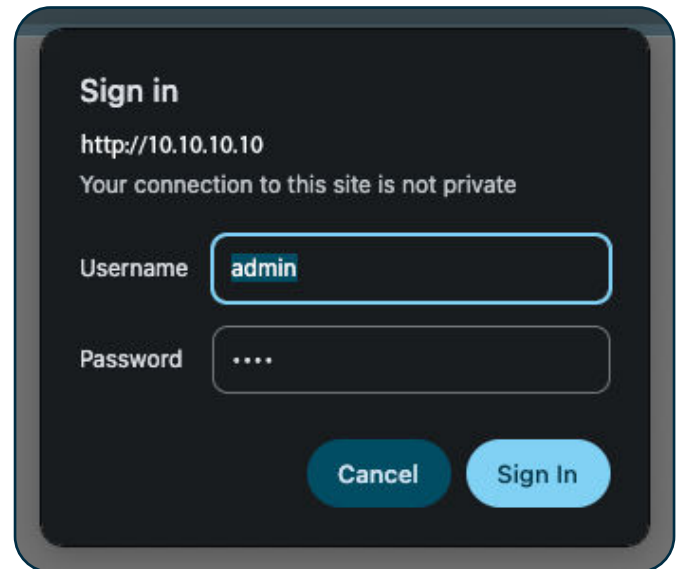

NSR Sign In Prompt

6.2 NSR Dashboard Overview

This area provides a comprehensive overview of your NSR.

Charger

- AC input status.
- Operation mode.
- Fan status*.
- Internal temperature.

Battery

- Battery voltage.
- Battery current.
- Battery temperature.
- Battery status.
- Battery condition test status (*UPS only*).

Load

- Output voltage (*UPS only*).
- Load current (*UPS only*).
- Over-voltage protection status.
- Overload protection status.

I/O

- Digital inputs status.
- Digital output status (*can be modified from dashboard*).

The screenshot displays the NSR750-24 dashboard with the following data:

Section	Parameter	Value	Unit	Status
Charger	Mains AC	-		FAIL
	Mode	On		BATT
	Fan	-		OK
	Int Temp	36.6	°C	
Battery	Voltage	23.1	V	
	Current	-13.9	A	
	Temperature	17.2	°C	
	Status	-		LOW
	BCT	Start	Stop	OK
Load	Voltage	22.9	V	
	Current	13.8	A	
	OVP	-		NORMAL
	OLP	-		NORMAL
I/O	Input 1	Off		
	Input 2	Off		
	Control 1	OFF		

NSR Dashboard

NOTICE

SOME FUNCTIONALITY SHOWN IS EXCLUSIVE TO UPS MODELS (SUCH AS LOAD AND BATTERY CONDITION TEST), NOT AVAILABLE ON BATTERY CHARGER MODELS.

6.3 Power Supply Configuration

This area of the web interface allows you to configure:

Charger Settings

- Temperature compensation enable / disable
- Output voltage in power supply mode (*UPS only*).
- Float charge voltage in charger mode.
- Maximum charging current.

Battery Settings

- Battery detection voltage level.
- Low voltage alarm threshold.
- Low voltage disconnect threshold.

Battery Test Settings (*UPS only*)

- Automatic battery condition test enable / disable.
- Battery condition test voltage level.
- Test duration (minutes)
- Test interval (in days).

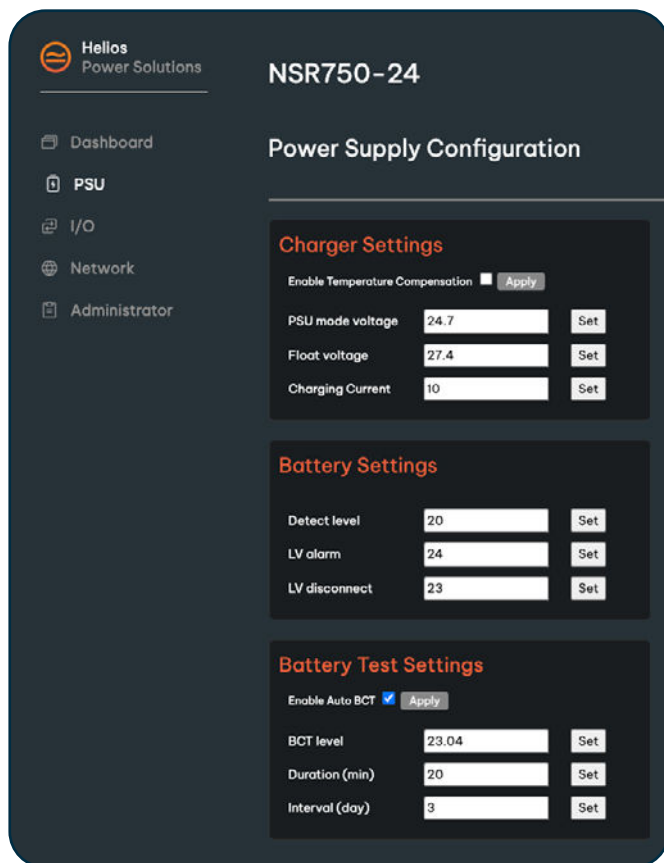

Power Supply Configuration Screen

6.4 I/O Configuration

This area of the web interface allows you to configure:

Digital Inputs (x2)

- Name, On and Off labels.

Digital Output

- Name.
- Trigger source (manual / automatic).
- Remote IP to ping other devices on the network.

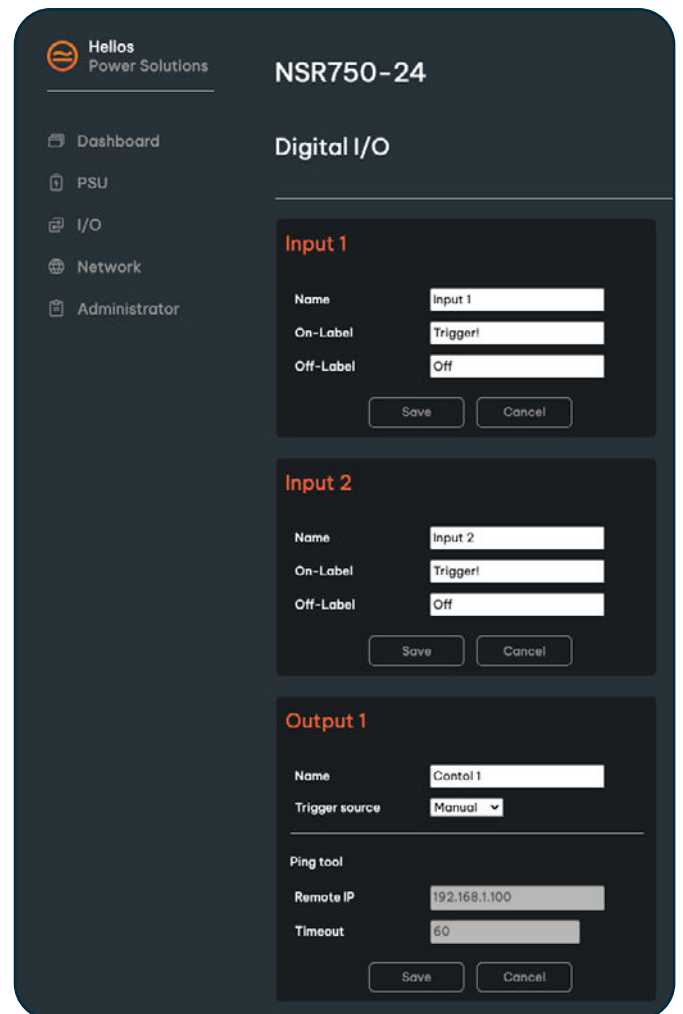

Digital I/O Configuration Screen

6.5 Network Configuration

This area of the web interface allows you to configure:

Network Settings

- IP Address.
- Subnet mask.
- Gateway.
- DNS Servers.
- Hardware MAC Address.

MODBUS-TCP Settings

- IP Filtering.
- Destination IP address.
- Port.

MODBUS RS-485 Configuration

- Modbus ID.
- Baudrate.

SNMP Settings

SNMP v3

- Enable / disable SNMP v3 .
(disable makes SNMP v1/v2c active).
- Username.
- Password.

SNMP v1/v2c

- Read community.
- Write community.

SNMP Trap

- Enable / disable SNMP trap.
- Destination IP address.
- Trap port.
- SNMP community.
- SNMP Trap v3 enable / disable.
- Username.
- Auth password.

CAUTION

CARE MUST BE TAKEN WHEN MAKING CONFIGURATION CHANGES TO THE NETWORK SETTINGS. AN ERROR IN CONFIGURATION COULD MAKE THE NSR UNREACHABLE.

The screenshot displays the Helios Power Solutions web interface for the NSR750-24 device. The interface is dark-themed and includes a sidebar with navigation options: Dashboard, PSU, I/O, Network, and Administrator. The main content area is titled 'Network' and contains several configuration sections:

- Network Settings:** Fields for IP Address (192.168.91.220), Subnet Mask (255.255.255.0), Gateway (192.168.91.1), DNS Server 1 (8.8.8.8), DNS Server 2 (8.8.4.4), and Hw Mac (FC:0F:E7:06:61:97). Save and Cancel buttons are present.
- Modbus-TCP Settings:** Includes a 'Filter IP' checkbox, Destination IP (192.168.1.100), and Port (1502). Save and Cancel buttons are present.
- Modbus-RS485 Settings:** Includes Modbus ID (1) and Baudrate (9600). Save and Cancel buttons are present.
- SNMP Settings:**
 - SNMP V3 (MD5 DES):** Checked. Username: helios, Auth Password: powersolutions.
 - SNMP V1/V2c:** Read Community: public, Write Community: private. Save and Cancel buttons are present.
 - Enable SNMP TRAP:** Includes Destination Address (10.10.10.2), Trap Port (1622), and SNMP Community (private).
 - SNMP-TRAP V3 (MD5 DES):** Includes Username (helios) and Auth Password (powersolutions). Save and Cancel buttons are present.

6.6 Administration Settings

This area of the web interface allows you to configure:

Login Settings

- Administrator username.
- Administrator password.

User Settings

- System contact email address.
- NSR location.

System Firmware

- Software version (information).
- Firmware version (information).
- Restore to system defaults.
- Restore to charger defaults.

Firmware Update

Firmware updates can be installed when available, to maintain your NSR software with the latest available version. This process is described on page 19.

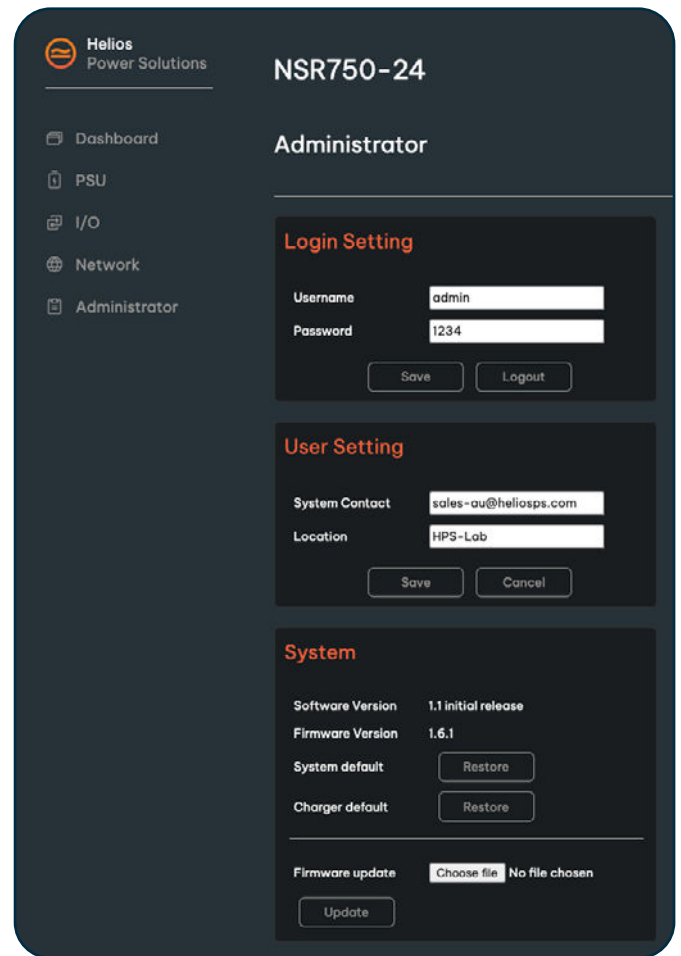

Administration Configuration

7. Maintenance

The NSR design is optimised to minimise maintenance effort therefore few maintenances are required. This section is intended to provide maintenance personnel with general information needed to resolve minor issues and maintain the NSR.

7.1 Firmware Updates

The NSR PSU series came with the original firmware when it is released, that may or may not be the latest version and from time to time the firmware may get upgraded to either address defects or enhance features. To upgrade firmware, please follow the steps below.

Please note: user-upgradable firmware is currently only available on SNMP/Ethernet optioned models.

1. Ensure the NSR is connected to the power supply mains, and power is available. If mains power is not available, do not attempt to update the firmware.
2. Ensure the management computer's network address is configured with the same subnet (IP address range) and netmask as the NSR.
3. Using your web browser, navigate to your NSR web interface and login to the NSR system as admin account, as shown on page 14
4. Navigate to the "Administrator" menu and locate the firmware option, then click on the "Choose File" field.
5. Browse your computer and locate the updated firmware for the NSR.
6. Click the "Update" button to update the firmware. Do not refresh your web browser or allow it to switch off. This may cause firmware corruption.
7. If the firmware checksum is incorrect or the firmware is corrupted, the NSR PSU will reject the new firmware and keep the existing firmware.
8. Allow time for the firmware to complete the installation process. The Web Interface will show progress of the update, and success or failure.
9. The NSR will reboot itself when complete and all status codes will return to normal.

CAUTION

DISRUPTION OF AC MAINS INPUT DURING FIRMWARE UPDATES WILL CAUSE CORRUPTION OF THE FIRMWARE UPDATE AND DISABLE THE NSR

7.2 Factory Reset Procedure

In the event of Ethernet misconfiguration or other situation where the NSR becomes unreachable, you can perform a factory reset to restore all settings back to the original factory defaults. This process cannot be undone.

Depending on your installation, you may disconnect all batteries and loads. Do not disconnect mains AC power during this process, or you may corrupt the NSR which will require return to Helios for repair.

To restore the NSR to factory defaults:

1. Press and hold the Standby button on the front panel for 15 seconds, then release.
2. The Red and Green LEDs on the rear panel will commence flashing, indicating that the NSR is restoring to factory defaults.
3. Once this is complete, the NSR will automatically reboot and return to normal first-run functionality.
4. All configuration settings will have been reset, including network configuration.

You can now reconfigure the NSR to suit your requirements and preferences.

NOTICE

FACTORY RESET PROCEDURE WILL RESTORE ALL PREVIOUSLY UPDATED ADMINISTRATIVE SETTINGS AND CAN RESOLVE MINOR ISSUES. THIS FUNCTION IS NOT ABLE TO RESOLVE A CORRUPTED FIRMWARE UPDATE AND THE NSR WILL NEED TO BE RETURNED TO HELIOS FOR SERVICE / REPAIR.

WARNING

POWER OUTPUT TO CONNECTED LOADS AND/OR CHARGING OF BATTERIES WILL BE INTERRUPTED DURING FIRMWARE UPDATES AND FACTORY RESET PROCEDURES.



DANGER - HIGH VOLTAGE

**HIGH VOLTAGES MAY BE PRESENT INSIDE THE NSR CASE EVEN WITHOUT MAINS POWER CONNECTED.
SERVICE BY QUALIFIED PERSONNEL ONLY.**

7.3 Fuse Replacement

The internal fuse may open under certain conditions including reverse polarity connection. To replace the fuse take the following steps:

1. Ensure that all AC mains and batteries are disconnected from the NSR.
2. Allow at least 30 seconds for any internal voltages to discharge.
3. Confirm that no LEDs are illuminated on the NSR.
4. Open the NSR lid by removing the 6 x countersunk screws securing it in place.
5. Locate the fuse as shown in the image below.
6. Replace the blown fuse with the same type and size (image representative only, fuse size and type varies by model).
7. Replace the lid of the NSR and fasten the 6 x countersunk screws.
8. Connect mains AC power and allow the NSR to boot.
9. Check status LEDs and/or monitoring systems to confirm fuse replacement successful.



Fuse location, type, and rating varies by model.

7.4 Cooling Fan / Dust Clean Up

Elevated internal temperatures for the NSR can be a result of obstruction / dust in the cooling fan.

To clean the internal cooling fan, take the following steps:

1. Ensure that all AC mains and batteries are disconnected from the NSR.
2. Allow at least 30 seconds for any internal voltages to discharge.
3. Open the NSR lid by removing the 6 x countersunk screws securing it in place.
4. Locate the fan as shown in the image below.
5. Use a vacuum cleaner to remove dust from the fan, taking care not to impact any other components.
6. If dust has accumulated around any ventilation areas of the case, remove these also.
7. Replace the lid of the NSR and fasten the 6 x countersunk screws.
8. Connect mains AC power and allow the NSR to boot.
9. Check status LEDs and/or monitoring systems to confirm normalisation of internal temperatures.



Cooling fan location.