

ERITECH® SYSTEM 3000

Installation, Operation and
Maintenance Manual

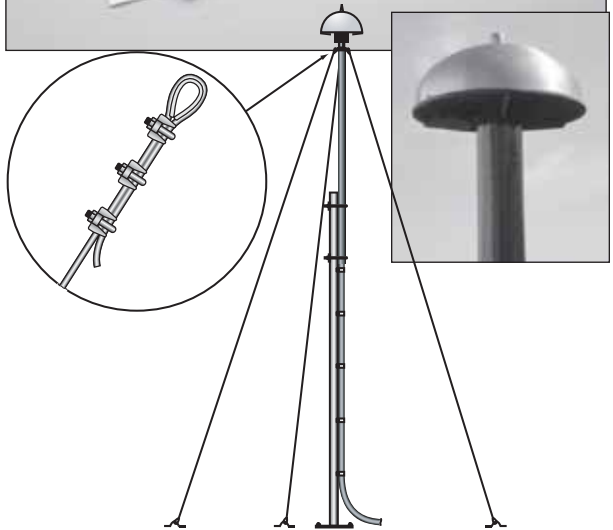

ERITECH® SYSTEM 3000 Installation, Operation and Maintenance Manual

Due to ongoing research into the phenomena of lightning and lightning protection technology and product improvement, ERICO reserves the right to alter any information and specifications contained herein at any time without notice. Installers of ERITECH® SYSTEM 3000 should check that they have the latest edition.

This manual replaces HB-HBCR-134 (Issue 1) edition number 6-2000.

The ERITECH SYSTEM 3000 is manufactured by ERICO.



International patents on the ERITECH SYSTEM 3000 are existing and pending.

ERITECH SYSTEM 3000 (or any other lightning protection system) does NOT offer 100% protection against all lightning events. However, correct installation is essential for the maximum level of safety.

Details of ERITECH SYSTEM 3000 Lightning Protection System

System Owner: _____

Location: _____

Date Installed: _____

Installation Contractor: _____

Purchased From: _____

Signature of Installation Contractor: _____



Copyright © 2009, 2012 ERICO International Corporation. All rights reserved.
CADDY, CADWELD, CRITEC, ERICO, ERITECH, ERIFLEX and LENTON are registered
trademarks of ERICO International Corporation.

**The ERITECH[®] SYSTEM 3000
Installation, Operation
and Maintenance Manual**

IP79131_B

Table of Contents

Pre-Installation Requirements	Page 4
Grounding Systems	Page 5
Downconductors	Page 5
Structural Bonding Braid & Conductive Structural Points.....	Page 6
Lightning Event Counters.....	Page 6
ERITECH® DYNASPHERE Terminals.....	Page 6
Masts.....	Page 7
Checking Lightning Protection Components on Receipt	Page 8
ERITECH® SYSTEM 3000 Installation	Page 9
Grounding Systems Installation	Page 9
Ground Resistance Lowering Compounds	Page 12
Insulation of Grounding Systems Page	Page 12
Bonding the Lightning Protection Ground to other Service Grounds.....	Page 12
Labelling.....	Page 13
Downconductors	Page 14
Downconductor Hauling.....	Page 14
Penetrations	Page 16
Routing	Page 16
Securing the Downconductor	Page 18
Use of Mast or Conventional Cable as the Downconductor.....	Page 19
Labelling.....	Page 20
Structure Bonding Braid	Page 20
Terminating the ERITECH® ERICORE Lower End	Page 24
Terminating the ERITECH ERICORE Upper End	Page 28
Terminals and Masts.....	Page 40
Terminals.....	Page 40
Masts	Page 40
Mast Bases	Page 41
Mast Couplings & Guying Points	Page 42
Guying	Page 44
Raising of Mast.....	Page 45
Lightning Event Counter.....	Page 48
Long Lengths of ERITECH ERICORE Downconductor	Page 49
Parallel ERITECH® ERICORE cables	Page 51
Series connected ERITECH ERICORE cable sections.....	Page 52
Practical Examples for long lengths of ERITECH ERICORE	Page 54
Certification	Page 55
Operation & Maintenance	Page 55
Maintenance Records	Page 58
Specifications	Page 59
Glossary	Page 62
Certificate of Compliance and Warranty Registration	Inside Back Cover



ERITECH[®] SYSTEM 3000

THE ERITECH[®] SYSTEM 3000 Installation, Operation and Maintenance Manual

Due to ongoing research into the phenomena of lightning and lightning protection technology and product improvement, ERICO reserves the right to alter any information and specifications contained herein at any time without notice. Users should check with ERICO to ensure they have the latest edition.

Warning:

1. ERICO products shall be installed and used only as indicated in ERICO product instruction sheets and training materials. Instruction sheets are available at www.erico.com and from your ERICO customer service representative.
2. ERICO products must never be used for a purpose other than the purpose for which they were designed or in a manner that exceeds specified load ratings.
3. All instructions must be completely followed to ensure proper and safe installation and performance.
4. Improper installation, misuse, misapplication or other failure to completely follow ERICO's instructions and warnings may cause product malfunction, property damage, serious bodily injury and death.

SAFETY INSTRUCTIONS: All governing codes and regulations and those required by the job site must be observed. Always use appropriate safety equipment such as eye protection, hard hat, and gloves as appropriate to the application.

The ERITECH[®] SYSTEM 3000 is manufactured by ERICO.
International patents on the ERITECH SYSTEM 3000 are existing.

Local Distributors should be the user's first point of contact with supply, delivery, installation, limited warranty, and checking of the system for compliance with Manufacturer's instructions.

Pre-Installation Requirements

This manual is a guide to the Installation, Operation and Maintenance of the ERITECH® SYSTEM 3000 Lightning Protection System.

It assumes that the system to be installed has been designed by an authorized ERICO representative. The system design will include:

- Grounding system design - a configuration should be designed as a result of soil resistivity analysis.
- Downconductor routes - chosen to avoid other services, maintain minimum bending radii and minimize downconductor run length.

- Downconductor securing requirements.
- Terminal types - operating environment.
- CAD analysis design software which determines terminal placement, mast & height requirements as well as protection level calculation.

All of the above are recommended for a successful installation. If there is any doubt about any of the points mentioned, please contact ERICO or your nearest Distributor for clarification.



Only attempt to install the ERITECH SYSTEM 3000 during storm-free periods.

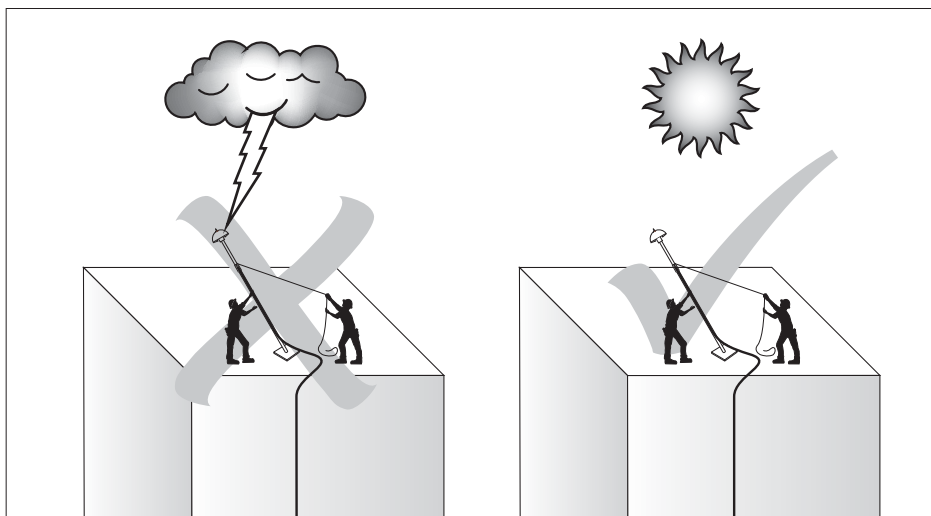

Figure 1.

The recommended order of installation is as follows:

1. Full installation of the grounding system.
2. Full installation of the downconductor.
3. Termination of the downconductor to the grounding system.
4. Upper termination of the downconductor (may already have been completed by ERICO) and connection to the ERITECH® DYNASPHERE air terminal.
5. Termination of bonding cable from upper termination to structure (if required).
6. Raise mast into position and secure.

Grounding Systems

The grounding system is critical to the integrity of any lightning protection installation and should include consideration of:

- Local Standards compliance (IEC 61024-1, BS 6551, AS1768-1991, NFPA® 780, C22.1-98, NEC® etc.)
- Available space / location.
- Natural soil conditions - resistivity of soil, soil moisture content, soil temperature range, etc.
- Location of underground services - Power, Communications, Fuel, Gas, Water, etc.
- Corrosive environments, ie: salt water, acid / alkaline contaminated ground mass.
- Use of suitable grounding rods such as ERITECH® rods.
- Minimization of risk to personnel.

Contact an ERICO office or Distributor if you require further advice on grounding systems.

Downconductors

The ERITECH® ERICORE downconductor or other recommended downconductor should have been selected during the design stage, as should the route, length and any preterminations of the downconductor.



Re-check intended route of downconductor immediately prior to installation to ensure that:

- There are no structural changes or additions that may effect the initial design.
- Most direct route possible to the grounding system with minimal number of bends and as flush with the structure as possible.
- Minimum bending radii maintained (500 mm, 20 in.).
- Parallel routing with other services - minimum separation = 2 m (80 in.).
- Attachment to the structure is at a maximum of every 1 m (40 in.) for the top 10% of the downconductor route and 2 m (80 in.) from then on.
- Pipe installations follow the instructions given on page 17.

Re-check:

- Securing of downconductor - saddles, cable ties, beam clamps, cable hangers, etc, are appropriate.
- Method of cable installation, ie. cable upper terminated on the outside of the drum - to be rolled off from the base of the structure, or cable upper terminated on the inside of the drum - to be rolled off from the top of the structure, (refer Figure 6 on page 15).
- The outer sheath of the downconductor must be electrically bonded to a conductive structural point within 5 m (17 ft) of the upper termination kit.

Structural Bonding Braid & Conductive Structural Points



When installing the upper end of the downconductor on a masonry structure (concrete panels, brick, etc), the downconductor should be secured directly to the structural steel work. In addition, the bonding cable (supplied in the termination kit) must be connected via 6 mm² (8 AWG) insulated copper cable to the nearest conductive structural point. This point should be where the downconductor first comes into contact with the structure and may be either structural steel work or the reinforcing within concrete panels or slabs.

It is recommended that this point be determined prior to the installation to allow for any site work or equipment that may be required prior to the installation.

The 6 mm² (8 AWG) cable is not supplied and the length of the cable will need to be determined and obtained before commencing the installation.

See Pages 18 to 24, figures 10-17 for more details and diagrams.

Lightning Event Counters

The Lightning Event Counter (LEC IV) is a device for registering and recording the number of strikes that the ERITECH® SYSTEM 3000 has intercepted. The design of this counter allows many installation alternatives on the downconductor as discussed in later text. Also, see Specifications on page 60.

The following should be considered prior to installation of the Lightning Event Counter:

- It is advisable to locate the LEC IV in a secure area that is not prone to contact with moving objects, theft, or vandalism.
- If the LEC IV is to be encased in an additional enclosure, ensure that it is mounted to enable easy access to the display, (see figure 32 on page 48).

ERITECH® DYNASPHERE Terminals

The ERITECH® DYNASPHERE is the air terminal of the ERITECH SYSTEM 3000.

Ensure that the appropriate air terminal has been provided.

Suitable for use in:

- General purpose applications
- High temperature environments
- Corrosive environments (salt or acid atmosphere)



Ensure the air terminal is supplied with the finial tip secured in place. The air terminal is supplied with three different finial tip configurations (two separate, and one secured in place), similar to that shown in photo 1. **It is important that the correct finial tip is installed, specific to the application.** Photo 2 shows the three different finial tip sizes, ranging from sharp to blunt in dimension. The sharp tip (middle), medium tip (left) and rounded tip (right). The application of each of these tips is detailed below:

- Sharp Tip – Terminal heights less than 20 m (65 ft)
- Medium Tip – Terminal heights less than 50 m (165 ft), greater than 20 m (65 ft)
- Rounded Tip – Terminal heights greater than 50 m (165 ft)

Note: heights listed refer to the actual terminal height above ground level

If required, replace the finial tip supplied with the appropriate tip for the application, and tighten firmly.

Warning – Do not install the ERITECH® DYNASPHERE without installing the correct finial tip.



1 – ERITECH DYNASPHERE with two spare finial tips.



2 – Three (3) ERITECH DYNASPHERE finial tip sizes.

Masts

There are three main types of mast configurations:

- Guyed - generally required for mast heights of over 3 m (10 ft) or for climatic conditions where wind gusts may exceed 160 km/h (100 mph). Always consult with a local civil engineer if in doubt. The mast is anchored at the base and then guyed using one or two guy sets, depending on the mast height and configuration, each with 3 lengths of non conductive guying material.
- Cantilevered - the lower third of the mast is secured to a vertical surface to provide support. These may also require guying depending on mast height.
- Free-standing - base support only.

Ensure that the configurations and heights for your specific installation conform to the design and consultation directives.

Specific advice for each mast configuration is provided on pages 40 to 47.

When all of the components for the ERITECH® SYSTEM 3000 have been received, they should be checked against the design "Bill of Materials" and for any possible shipping loss or damage.

Checking Lightning Protection Components on Receipt

Before installation, in particular, check the following:

Terminal(s)

- ERITECH® DYNASPHERE terminals have not been dented in any way.
- The correct finial tip has been installed, based on the overall height of the air terminal above ground.

ERITECH® ERICORE Downconductor(s)

- The cable drum (if supplied) is in a serviceable condition.
- Correct length(s)
- That there is no obvious damage to the cable.

- Is terminated as required. If the downconductor has been preterminated before shipment, check that the termination is still intact and in good order. See note on Page 14 on removing protective covers.
- If the Upper Termination Kit has been supplied separately, check that the Cold-Shrink tube in the kit is in good order, has no tears or cuts and has not collapsed.

This information along with downconductor lengths and quantities (if more than one length on the one drum), will be printed on a label on the side of the Cable Drum(s).



ERITECH® SYSTEM 3000 Installation

During the installation of the ERITECH® SYSTEM 3000, all site restrictions and safety requirements must be followed.

It is important to follow the recommended order of installation:

1. Full installation of the grounding system.
2. Full installation of the downconductor.
3. Termination of the downconductor to the grounding system.
4. Upper termination of the downconductor (may already have been completed by ERICO®) and connection to the ERITECH® DYNASPHERE air terminal with correctly sized finial tip.
5. Termination of bonding cable from upper termination to structure.
6. Raise mast into position and secure.



Only attempt to install the ERITECH SYSTEM 3000 during storm-free periods.

If the terminal must be raised before being connected to the ground system, or cannot be immediately connected, then attempt to connect the lower end of the down-conductor to either the structure steel reinforcing or some other reasonable ground point.

Grounding Systems Installation



Prior to the installation of the lightning protection grounding systems, it is important to refer to site drawings of all underground

services to ensure that these are avoided and not interrupted during trenching, excavation, boring or driving ground rods, (see figure 4 on page 11).

Care must be taken to follow the ground survey design. Ensure the correct materials have been provided and are used to achieve an acceptable Ground DC resistance (typically $<10\Omega$).

Examples of typical grounding systems that may be used (Note: these may or may not be relevant to the specific ERITECH SYSTEM 3000 design) are shown in figures 2 and 3 on page 10.

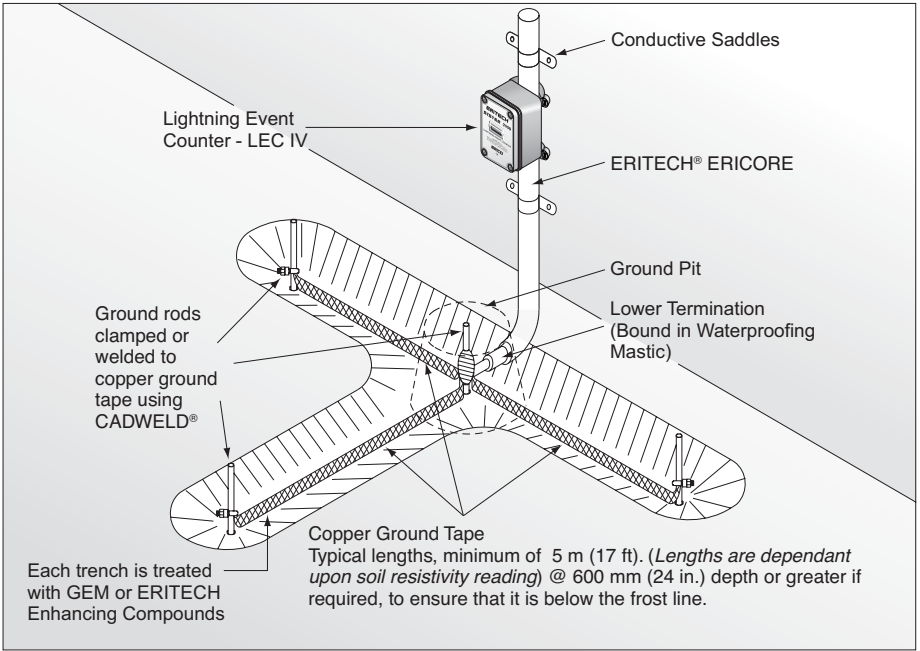

Figure 2: Radial Ground.

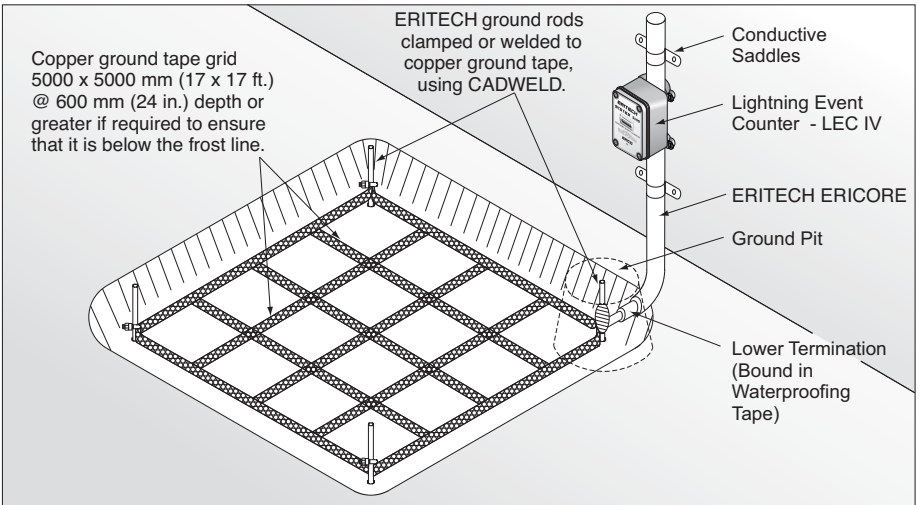

Figure 3: Grid Ground.



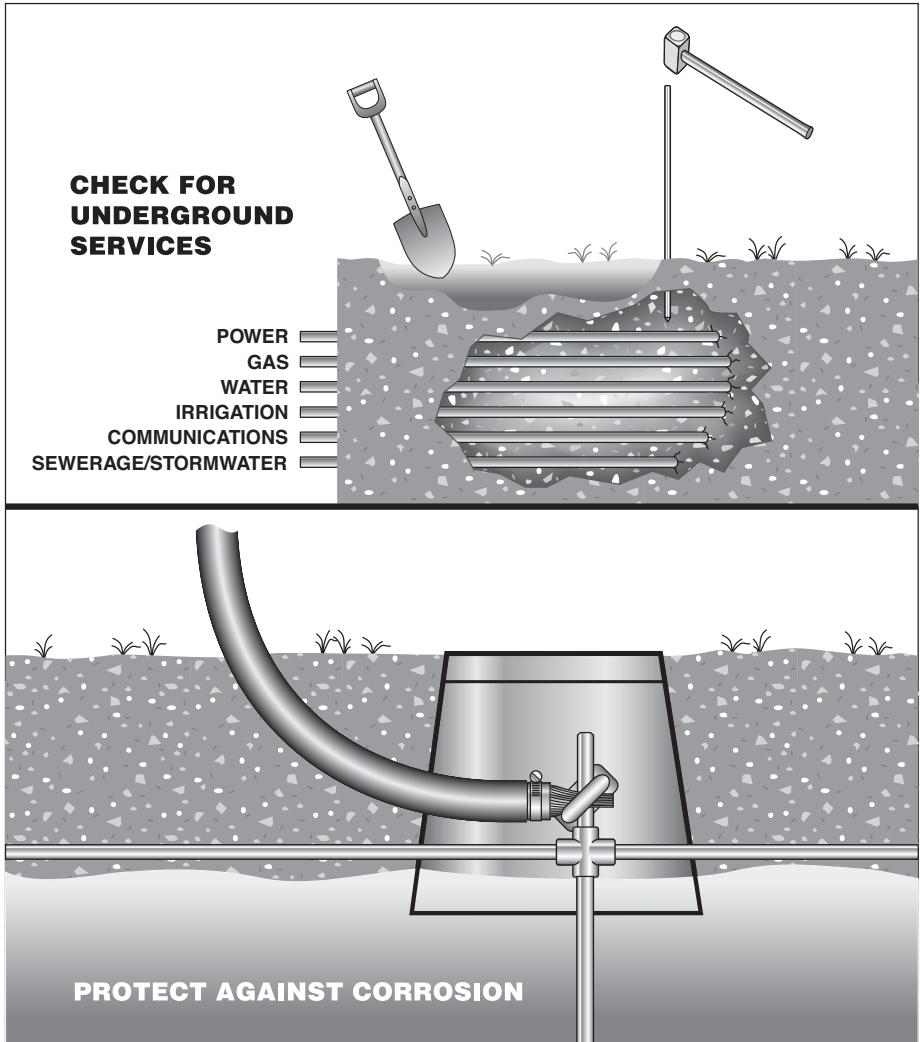

Figure 4: Precautions required for ground pit excavation and lower termination corrosion protection.

It is advised that a ground pit is installed where the end of the downconductor terminates to the ground system.

This provides a convenient access point for disconnection and future testing.

When using ground rods it is advisable to:

- Use driving heads to prevent mushrooming on top of the rod.
- Use driving heads when using coupled rods.
- Use a post or picket driver.

When bonding the grounding system components, try to use the recommended methods suggested below:

- CADWELD® connections must be used to provide permanent electrical bonding, corrosion resistance and mechanical strength between conductors, including most types of copper cable, bar, rod, tape, structural steel work, reinforcing steel and pipe.
- Supplied ground rod clamps should be used for termination of ERITECH® ERICORE downconductors directly to ground rods. This allows later disconnection for maintenance requirements.
- Use of aluminum lugs or couplings is prohibited.
- Waterproofing mastic tape should be used for waterproofing corrosion vulnerable connections.

Ground Resistance Lowering Compounds

Ground enhancing compounds, (such as GEM) are recommended and supplied when the existing soil mass has a high resistivity.

These compounds can be used to increase the total surface area of grounding conductors, thereby reducing the ground resistance / impedance.

Compounds may require water and a mixing container.

When applying these compounds, be sure to take necessary handling precautions as advised by the product instructions, and ensure that the directions for use are followed correctly.

Insulation of Grounding Systems

In some installations, it may be necessary to insulate part of the ground system from an area of the surface, for the purposes of safety or isolation, (pedestrian walkways, proximity to other services, etc.). In this situation, it is recommended that a minimum of 70 mm² (2/0 AWG), insulated copper cable is run in PVC conduit to the connection point (start) of the intended ground system. This conduit should be at a depth of at least 600 mm (24 in.), or greater if required, to ensure that it is below the frost line to the start of the intended ground system.

Another possible design method for reducing surface step-potentials may be to insulate the ground system for the first few meters of depth from the surface. This is done by isolating the initial injection point of the downconductor from the surface of the ground mass by running it through PVC conduit to the required depth before exposing it to the ground mass.

Bonding the Lightning Protection Ground to Other Service Grounds

Where separate grounds exist eg: Structure, Power, Communications and Lightning Protection, they should be bonded together to form an equipotential ground plane. This will eliminate the possibility of ground loops and potential differences arising under transient conditions.



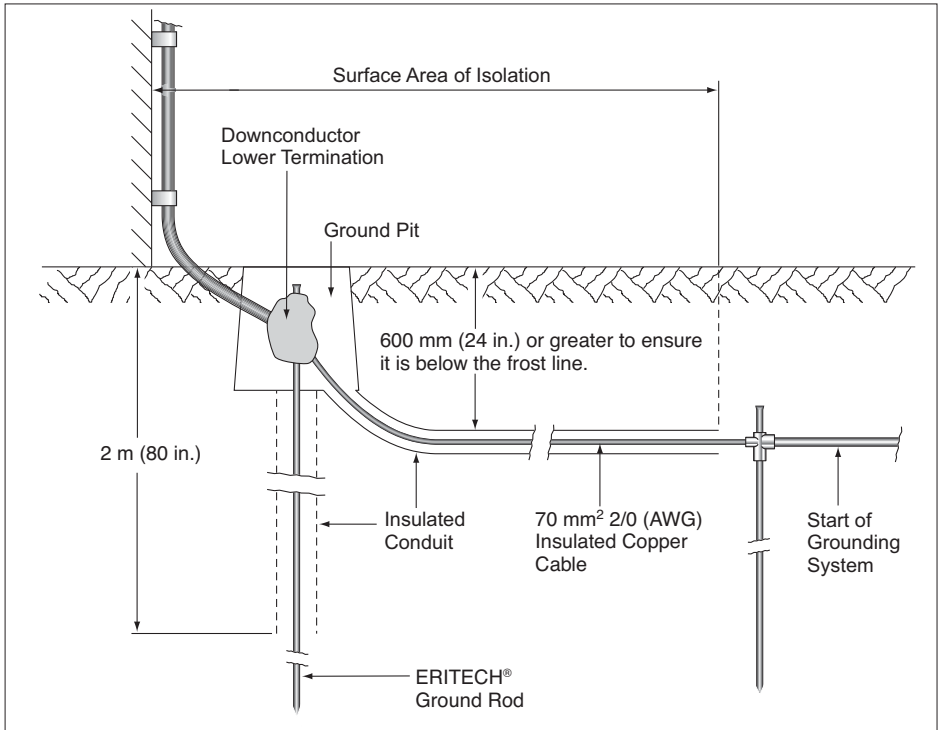

Figure 5: Various methods of isolating the ground system.

Authorization may be required by the particular service providers before bonding of these grounds takes place.

Bonding cable must be 70 mm² (2/0 AWG) minimum depending on local standards. In some circumstances, it may be necessary to use a Transient Earth Clamp (ERICO Part No. TEC100C) which effectively bonds all grounds to the same potential under transient conditions, to satisfy service providers.

For further information, it is advised that local applicable standards are consulted, ie IEC 61024-1, BS 6551, AS1768, NFPA® 780, C22.1-98 and NEC®.

Labelling

The labelling of ground pits or grounding systems to local requirements is the responsibility of the customer / installer.

Downconductors



Depending on site requirements, the downconductor(s) may have their upper terminations completed at a pre-specified end of the cable by ERICO before shipment. These terminations will be protected by a short length of flexible PVC tube.

It is VERY IMPORTANT that when removing these tubes, they are not removed with a knife or cut in any way as this will damage the outer layer of the termination. It is suggested that the tape and cover are best removed by hand. (See figure 6)

All ERITECH® purpose-designed downconductors have a semi-conductive outer sheath which is approximately 2 mm (0.08 in.) thick. Rough or careless handling of the downconductor can damage this sheath and compromise its performance.

Downconductor Hauling

Locate the downconductor cable drum at the appropriate location, (refer to figure 6).

When hauling the downconductor, use the following guide points:

- Ensure that the cable drum, if supplied, is in a serviceable condition.
- If the downconductor has been upper terminated on the outside of the drum, then the downconductor must be hauled off the drum from the ground.
- If the downconductor has been upper terminated on the inside of the drum, then the drum must be at or near the top of the structure, so that the downconductor can be unwound from the drum towards the base, (see figure 6).

- When using slings or ropes to haul downconductors, use MULTIPLE hitches around the cable.
- DO NOT sling from the termination coupling or cold-shrink section of the terminated downconductor.
- DO NOT use cable stockings over TERMINATED downconductor ends.
- Protect the downconductor from abrasion and tearing when hauling over rough surfaces, at all times, especially around corners or through penetrations.



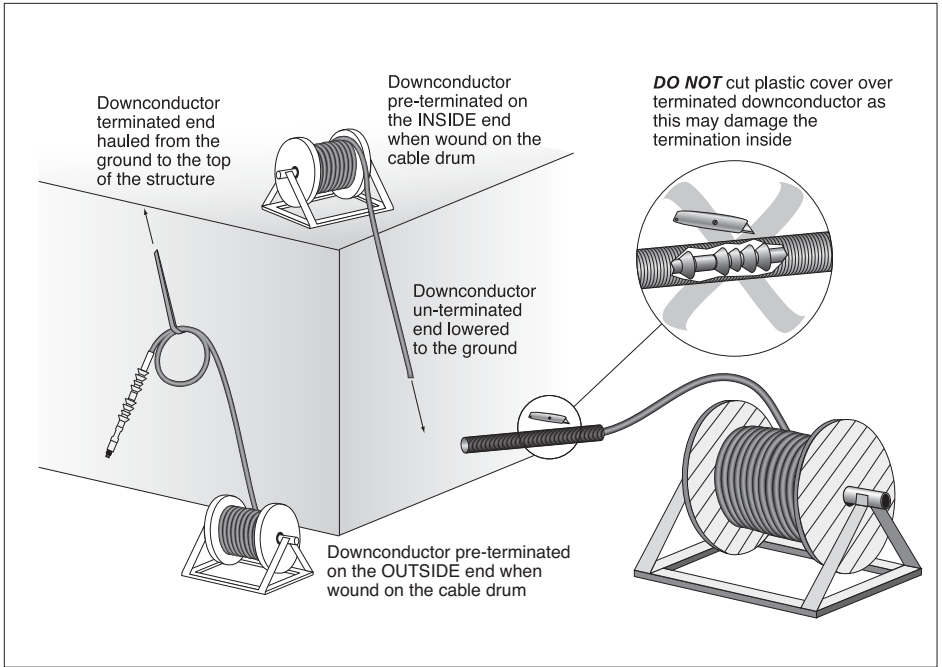

Figure 6: Cable pre-termination and drum locations.

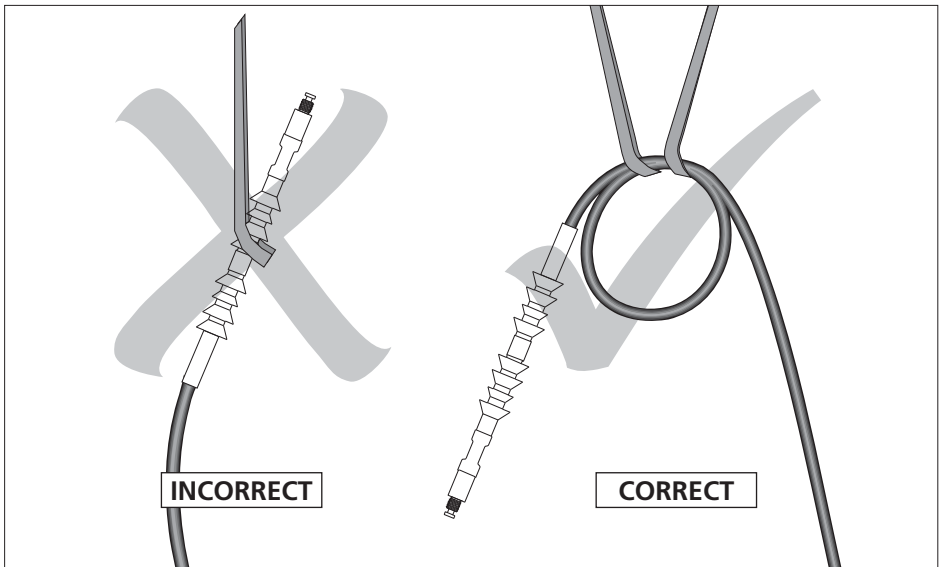

Figure 7: Incorrect and correct cable hoisting methods.

Penetrations

Before routing the downconductor through any penetrations, ensure that:

- If un-terminated, a minimum hole diameter of 50 mm (2 in.) is provided.
- If terminated, a minimum hole diameter of 60 mm (2 3/8 in.) is provided.
- Enough physical protection (conduit or similar) is provided to stop the downconductor from being damaged when being fed through the penetration.
- When feeding the upper termination of the downconductor through any penetrations, the termination sheds (flanges) should be temporarily wrapped in insulation tape to reduce their diameter and protect them against abrasion. This is very important as the cold-shrink tubes are susceptible to tearing if nicked or scuffed.

If either side of the penetration requires environmental protection ie: waterproofing, air-con pressure seal, etc., use a suitable sealant or deck sealing gland.

Routing



The route taken by the downconductor is very important and must follow these rules:

- Carefully survey the intended route of the downconductor immediately prior to the installation to check for any alterations that may effect the original design, ie: structural changes, new antenna or mast installations, air conditioning towers or ducting, etc.
- Use the most direct route practical to minimize the downconductor length.
- To minimize the risk of side-flash, DO NOT route the downconductor back beside itself after change of direction, ie: 180°.
- Minimize number of bends.
- Minimize strain on the downconductor during installation.

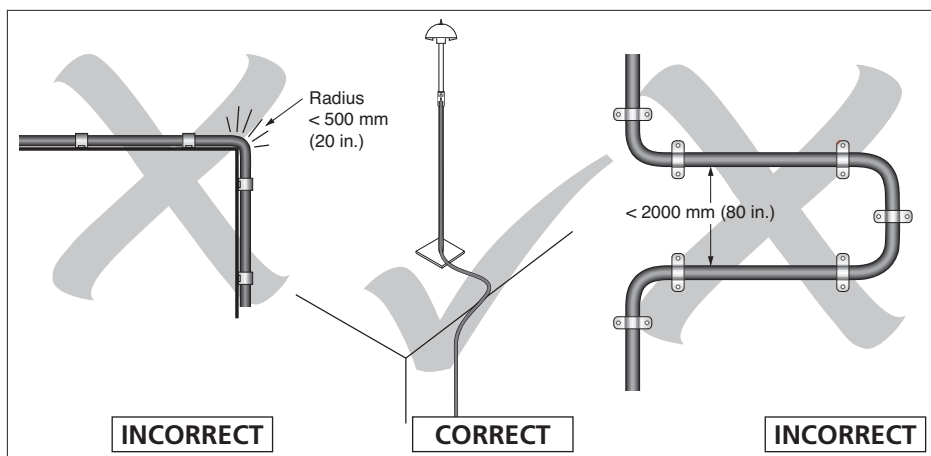



Figure 8: Correct & incorrect cable routing methods.



- Ensure bend radius maintained >500 mm (20 in.).
- Parallel routing with other services - Minimum separation = 2 m (80 in.). Try to isolate as much as possible from other services.
- If the downconductor must cross other services, ensure that it crosses at right angles to minimize any inductive effect.
- The lower end of the downconductor must terminate as close as possible to the initial injection point of the grounding system.

-  Allow 500 mm (20 in.) of slack in the length of downconductor at the upper end of the cable to facilitate mast erection and correct seating of the ERITECH® DYNASPHERE terminal in the top of the FRP mast.
- Where isolation of the downconductor is required, (for physical or proximity safety reasons) install the cable in a suitable insulating conduit with a minimum wall thickness of 3 mm (1/8 in.).

NOTE: This is the only time that the downconductor should be isolated from the structure and generally only for 2.4 m (8 ft.) maximum. **DO NOT route the entire length of downconductor in insulated conduit.**

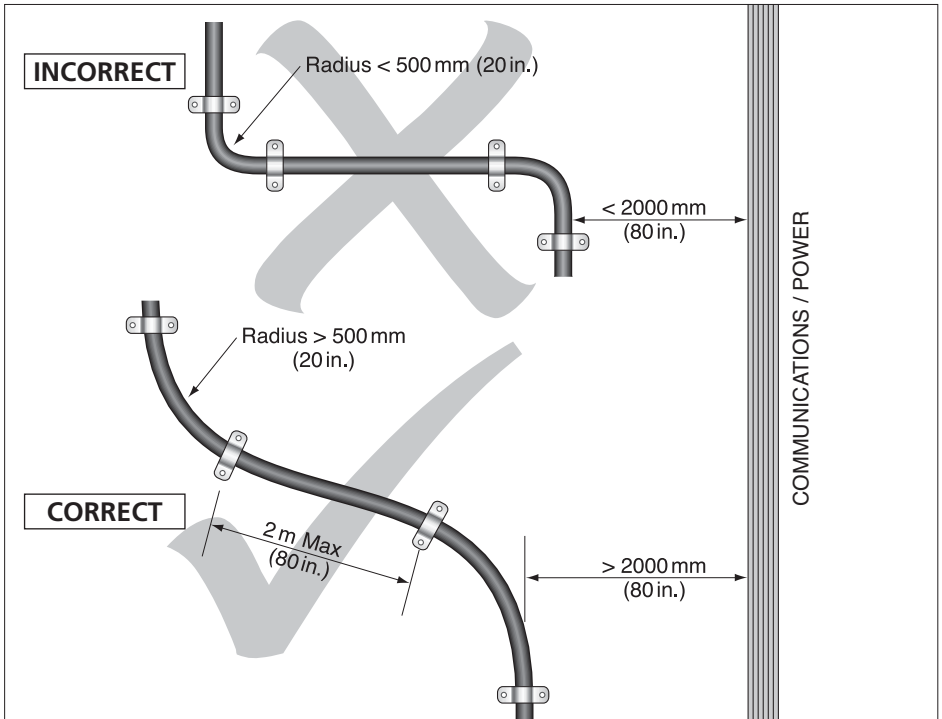

Figure 9: Correct & incorrect cable routing.

- To seat the terminal correctly in the top of the FRP mast, any cable slack will have to be removed from the mast while also minimizing any stress on the upper termination sheds (flanges) by twisting the FRP mast against the terminal for at least one turn.



If the downconductor is damaged during installation, it must be checked by an ERICO

representative to see if the damage will effect its safe operation.

Securing the Downconductor



Securing of the downconductor not only provides a mechanical attachment to the structure, but also an Electrostatic connection to the structure via the semiconductive outer sheath of the downconductor cable.

It is important that the downconductor is both physically and electrically secured to the entire length of the structure to relieve both physical and electrical stresses along the downconductors' length.

The electrical bonding of the downconductor is especially important for at least the first 10% of the downconductor route from the upper termination, and for this reason the downconductor must be secured at least every 1 m (40 in.).



ERITECH® brand of saddles and conductive clamps are recommended for the purpose of securing the downconductor. These have been specifically designed and manufactured to mechanically secure and electrically bond the ERITECH® ERICORE to the structure, while minimizing stress points on the cable.

Use of a brand of saddles other than ERITECH can compromise the outer sheath, creating high stress points which can lead to flashover, (see figure 10).

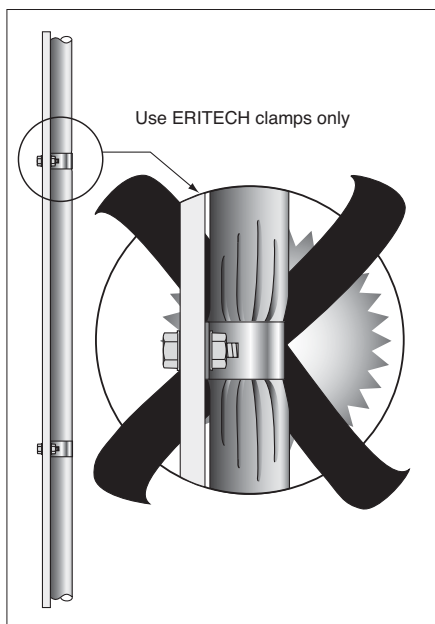
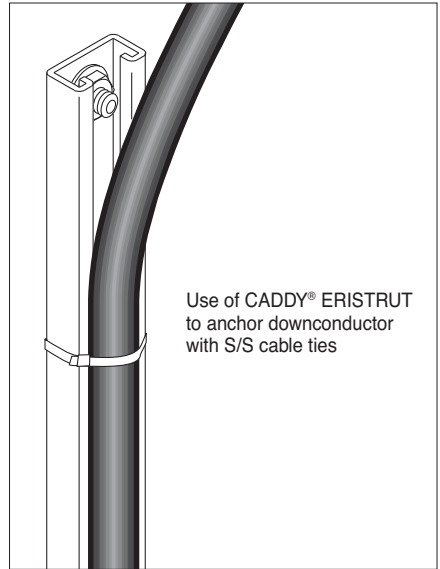

Figure 10: Detail shows the need to use ERITECH Clamps.

- For brick and concrete walls or roofs, use the ERITECH® brand of stainless steel saddles. These have two 6 mm (¼ in.) diameter holes on either side and are suitable for use with masonry anchors. These saddles can also be used with other suitable fastenings against wood, fiberglass and metallic surfaces.
- When securing externally to round section structures such as pipes, tower legs, masts, etc, stainless steel cable ties are recommended. Ensure that these are firmly secured.
- For securing to other structures such as angle iron, ie: radio towers, structural beams etc., use CADDY® brand of beam clamps and suitable cable clamps from ERICO.
- If the downconductor is to be routed above a false ceiling, ensure that it is fixed to the underside of the concrete floor slab.
- Use of exothermic fastening methods on ERITECH brand of saddles is NOT recommended.
- Use of CADDY® ERISTRUT (or other similar strut system) is recommended where suitable, (see figure 11).

Use of Mast or Conventional Cable as the Downconductor

In some installations, the mast may be used as the downconductor or alternatively, in short-run installations, conventional cable is sometimes used. In these cases, a Terminal Lug Coupling Adaptor will be supplied to allow a lugged 50 mm² (1/0 AWG) or 70 mm² (2/0 AWG) (depending on local minimum standards) cable termination to the base of the ERITECH® DYNASPHERE, (see figure 12).



Use of CADDY® ERISTRUT to anchor downconductor with S/S cable ties

Figure 11: Downconductor anchored to strut.

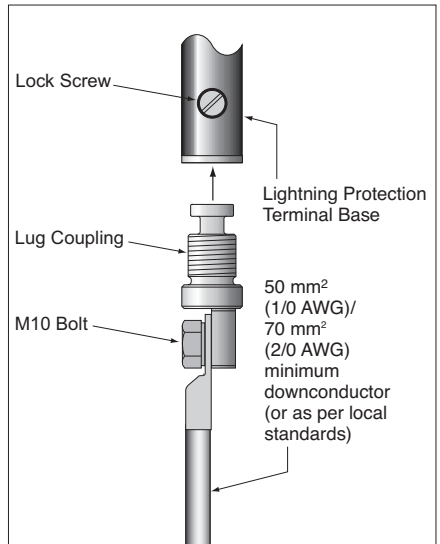

Figure 12: Lug Coupling for non-ERITECH® ERICORE downconductors.

Labelling

Vital Warning Labels must be located at eye level:

- Where there is the possibility of personnel being in close proximity to the cable.
- Where the downconductor terminates to the grounding system.
- At the mast base.

There is a VITAL WARNING LABEL supplied in the front cover of this manual and also one supplied in each of the upper and lower termination kits.

If more labels are required, contact your nearest ERICO® Distributor.

Structure Bonding Braid

To help ensure that the upper end of the downconductor can be adequately electrically bonded to the structure, a Structure Bonding Braid has been provided at the base of the upper termination of the downconductor. This braid is a 75 mm (3 in.) tail which exits from under the termination coldshrink and is supplied with a connector to allow connection to a 6 mm² (8 AWG) copper cable (as mentioned in the following text). This must be connected to a conductive structural point to relieve the electrical stresses on the downconductor and masonry surfaces.



The use of the Structure Bonding Braid is NOT optional, and MUST always be used.

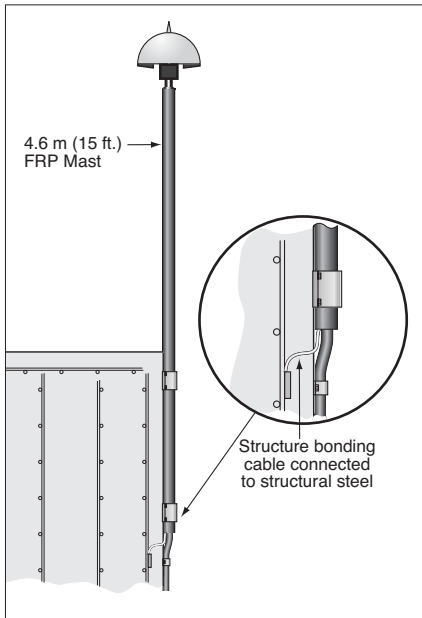

Figure 13(a): Cantilevered FRP section on building.

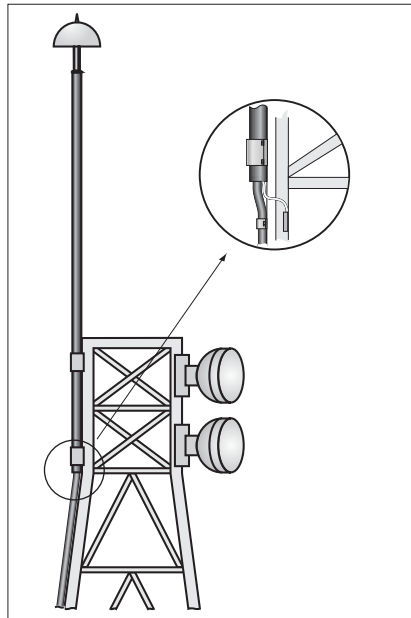

Figure 13(b): Cantilevered FRP section on Radio Tower.



After routing the downconductor, it must be kept in constant physical contact with the structure via conductive fixings as follows:

- The top 10% of the downconductor from the terminal must be secured at least every 1 m (40 in.). This includes metallic mast sections.
- The lower 90% of the downconductor must be secured at least every 2 m (80 in.).
- This includes routing inside any type of conductive pipe or conduit, (see Fig. 17).
- When mechanical fastening of the cable every 2 m (80 in) is not possible, a maximum unsupported length of 35 m (114 ft) is allowed as long as the installation adheres to the electrical bonding requirements (see use of cable ties in figure 17).



When using metallic lower sections of mast (ie: aluminum), then the downconductor **MUST** be secured with ERITECH® brand of saddles to the mast at 1 m (40 in.) intervals (max.). The mast in turn must be electrically bonded to the nearest conductive structural point. In this case, the structure bonding braid must connect to the inline coupling, (see Fig. 14).

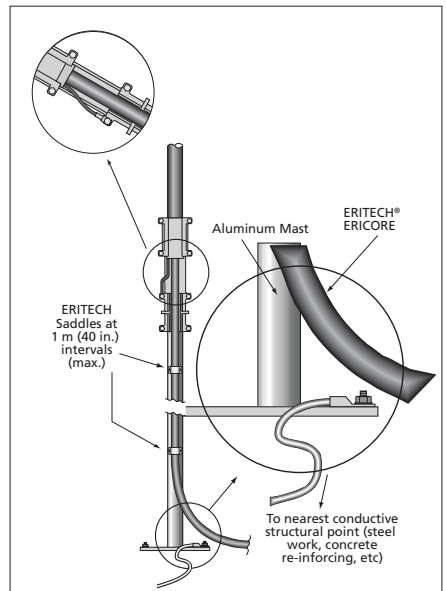

Figure 14: Connection of Structure Bonding Braid in FRP and F.S. masts.

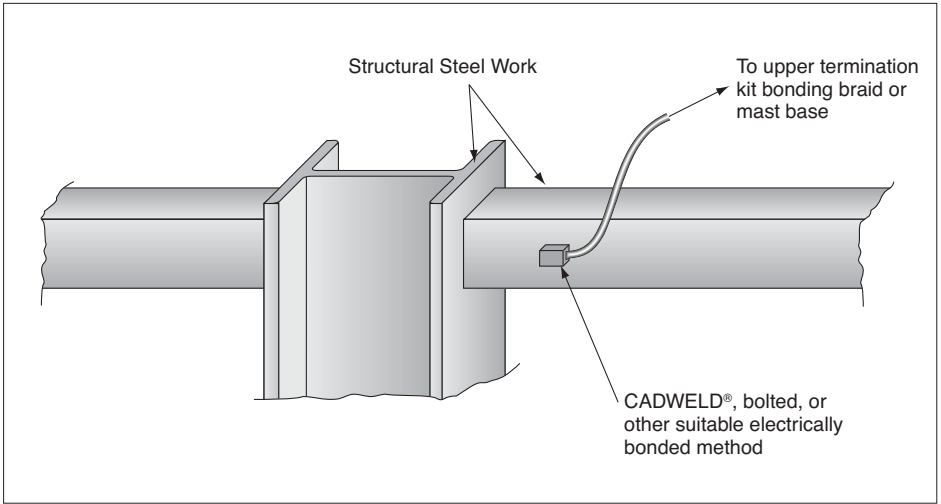

Figure 15: Connection of bonding cable to structural steel work.

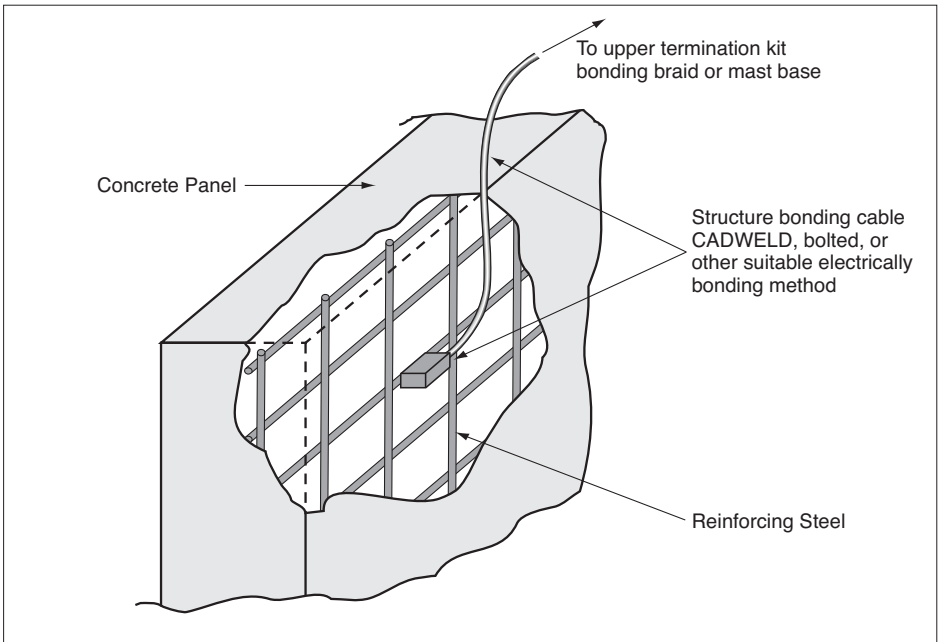

Figure 16: Connection of bonding cable to concrete reinforcing.



The 6 mm² (8 AWG) copper cable used to connect the structure bonding braid to the structure must be one continuous length. Joins in this cable would represent a potential maintenance issue.

Any metallic surfaces that the downconductor may be secured to, if possible, should be electrically connected to the structural steel work.

Also, when using a metallic mast (ie: free standing light pole), the structure bonding braid must be connected to the top of the metallic mast using 6 mm² (8 AWG) insulated copper cable, (see figure 17).

To bond the downconductor inside a conductive non-ferromagnetic mast pipe or conduit, secure two stainless steel cable ties around the downconductor at every 1 m (40 in.) or at 2 m (80 in.) intervals with their tails left on, aligned at 180° to each other so that when fed into the pipe, they maintain contact with the inside wall of the pipe, (see figure 17). The maximum length of the cable installed inside the mast pipe or conduit should not exceed 35 m (114 ft).

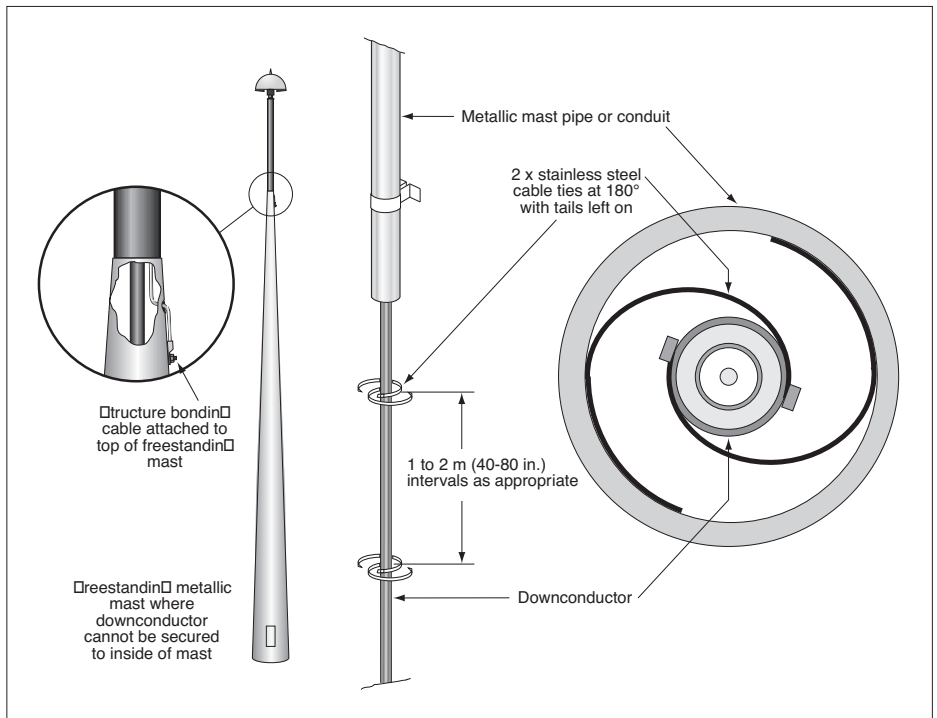

Figure 17: Electrical bonding of downconductor within metallic mast section or pipe.

Terminating the ERITECH® ERICORE Lower End

Instructions for ERITECH ERICORE Downconductor



*The downconductor has been specifically designed to cope with extremely high impulse voltages and currents. Due to the nature of the downconductor construction, and its working environment, it is **Very Important** that each step be followed and carried out exactly as per the following instructions.*

The downconductor can be lugged, (as detailed overleaf) and then connected to the ground rod using the ground rod clamp, or alternatively, it can simply be connected to the ground rod using only the ground rod clamp.

Tools required for Terminating Lower End of ERITECH ERICORE

1. Sharp Knife
2. Tape Measure
3. Flat Blade Screwdriver
4. Hacksaw
5. 150 mm (6 in.) Adjustable Spanner / Wrench
6. Roll Spring - (supplied with Upper Termination Kit)
7. Insulation Cutting Tool - (supplied with Upper Termination Kit)
8. Crimper (90 mm²) (only required if the cable lug is to be used)

The Lower Termination Kit Consists of:

- 1 x Hose Clamp
- 1 x 90 mm² Lug
- 1 x 2.5 mm² x 105 mm (12 AWG x 4 1/8 in.) Bare Copper Wire
- 1 x 'U' Bolt type Ground Rod Clamp (13-15 mm, 1/2 - 5/8 in. Rod Diameter.)
- 1 x Water Proofing Mastic
- 1 x Vital Warning Label
- 2 x Rubber Gloves
- 1 x Instructions



Refer to Figure 18 for the following instructions (1 to 10).

1. With the hacksaw (or appropriate cutters), cut the downconductor cable to length, leaving enough cable to be able to easily and directly route it to the ground termination.
2. At a distance of 100 mm (4 in.) from the end of the cable, carefully cut a shallow notch into the black outer insulation, no deeper than 1 mm, ($\frac{3}{64}$ in.). Using the insulation cutting tool, cut around the circumference of the black outer insulation until the copper screen underneath is exposed.



Important! The insulation cutting tool uses friction to cut into the sheath and is less likely to damage the layers underneath than using a knife.

3. Use a knife to carefully cut along the 100 mm (4 in.) length of black outer insulation to a depth of no more than 1 mm. ($\frac{3}{64}$ in.). Be careful not to cut too deeply so that the copper layer underneath is not exposed or damaged. Starting from the end of the cable, carefully remove the outer insulation and discard.

4. Carefully clean up the insulation friction cut, removing any burrs for a neat finish.

5. Fit the roll spring 15 mm ($\frac{5}{8}$ in.) from the end of the outer insulation over the exposed copper tape (roll spring supplied with upper termination kit).

6. Remove the copper tape up to the roll spring (exposing black triple extrusion layers) by unrolling, then tearing the tape up and back over the edge of the roll spring at about a 45° angle. If necessary, cut about 6 mm ($\frac{1}{4}$ in.) of the copper tape up against the roll spring with a knife and then tear over the spring.

7. Wrap one end of the 2.5 mm² x 105 mm (12 AWG x 4 $\frac{1}{8}$ in.) bare copper wire (supplied with the kit) around the hose clamp, then fix the hose clamp over the exposed copper screen of the downconductor and tighten with a screwdriver.

8. At 85 mm (3 $\frac{3}{8}$ in.) from the end of the cable, carefully cut around the circumference of the black triple extrusion layers with a knife, then, from the first cut, along the length of the insulation to the end of the cable. Remove the layers and discard.

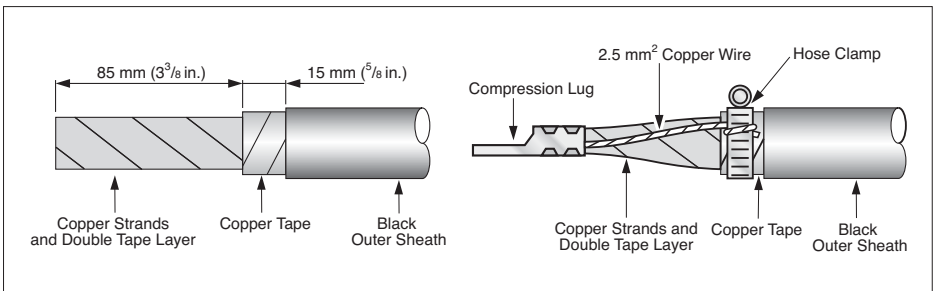

Figure 18: Stripping lengths downconductor.

9. Lay back all of the copper strands and tape cut off the filler core with a hacksaw or knife as close to the strands and tape as possible without damaging them. Lay the copper strands and tape neatly and uniformly back in place.

10. If using the compression lug, combine the end of the 2.5 mm² (12 AWG) bare copper wire from the hose clamp with the downconductors' copper strands and then fit ALL conductors into the 90 mm² lug supplied with the kit. Make sure that it is fitted correctly before crimping with an appropriate crimper.

11. Securely connect the lugged down-conductor to the grounding system.

12. If the 'U' bolt ground rod clamp (or other method) is to be used, then ensure that the 2.5 mm² (12 AWG) bare copper

wire from the hose clamp is bonded with the final grounding connection and all of the other downconductor copper strands and tape. Then securely tighten the whole connection.

Note: The ground rod clamp supplied in this kit must be tightened to 44Nm (32 lbf.ft.).

13. Make sure the lower termination is free of moisture. Using rubber gloves, shape the waterproofing mastic (supplied) around all of the exposed areas of the lower termination.

Note: Depending on the environment of the lower termination, it may be necessary to wrap a sealing tape or mastic around the waterproofing mastic to stop it from drying out over time.

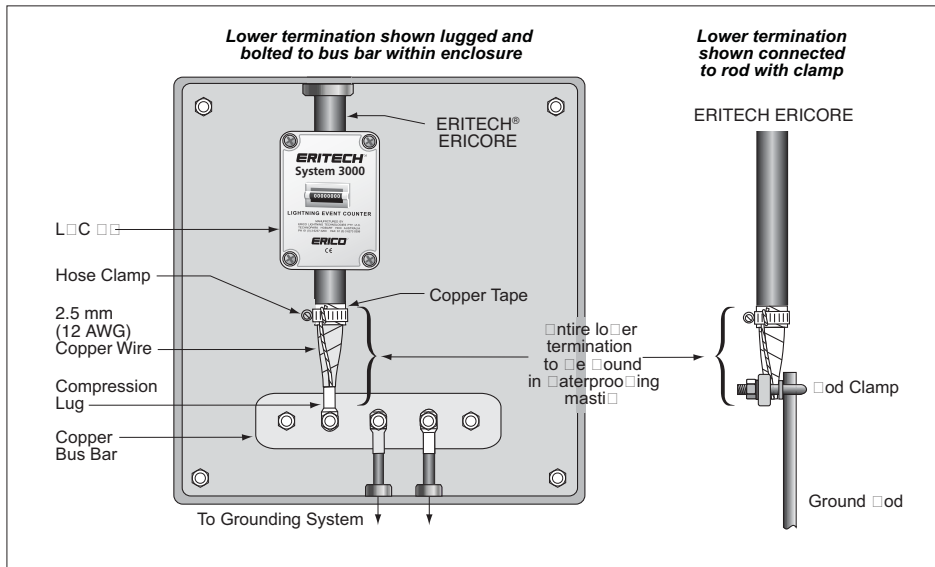

Figure 19: Termination to bus bar and ground rod.





It is important to cover all exposed metallic surfaces (copper, hose clamp, lug, ground rod clamp, etc.) To avoid the risk of corrosion.

14. Place the 'VITAL WARNING' label (supplied in the kit) in a suitable place near the downconductor.

Note: *If an upper termination has already been performed on the cable, then start with STEP 23 on page 37.*



ERITECH® ERICORE down-conductor cable has been specifically designed to cope with extremely high impulse voltages and currents. Due to the nature of the cable construction, and its working environment, it is very important that each step is followed and carried out exactly as per the following instructions.

The special insulation cutting tools have been supplied to facilitate the cutting of the cable's insulation layers, while preventing damage to other layers, such as the copper foil.

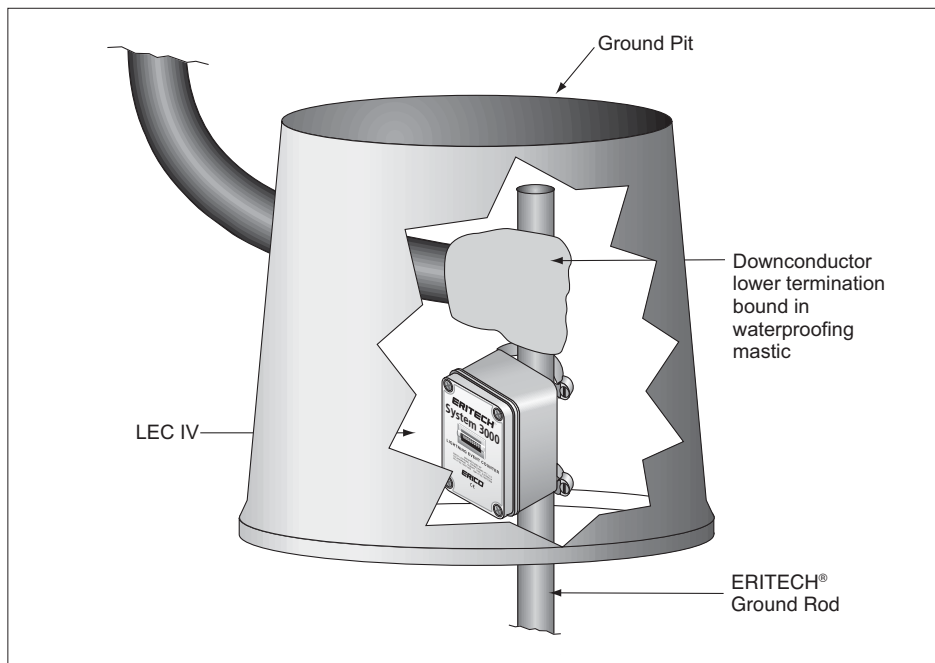

Figure 20: Completed termination for downconductor.

The Insulation Cutting Tool uses friction to cut into the sheath and is less likely to damage the layers underneath than using a knife. When the instructions call for the knife to be used, be sure not to cut any deeper than instructed.

If the instructions are not followed correctly, or if any of the insulation layers or the copper foil are incorrectly cut, then the integrity of the lightning protection is affected.

Refer to Figure 21 on page 36 for the following instructions (1 to 11).

- 1.** At a distance of 600 mm (23 $\frac{3}{8}$ in.) from the end of the cable, carefully cut a shallow notch into the black outer insulation no deeper than 1 mm ($\frac{3}{64}$ in.). Then, using the insulation cutting tool, cut around the circumference of the black outer insulation until the copper screen underneath is exposed, (see photo 3).
- 2.** Using a knife, carefully cut the outer insulation of the cable to a depth of no more than 1 mm ($\frac{3}{64}$ in.), for the full 600 mm (23 $\frac{3}{8}$ in.), in the direction of the end of the cable. Be sure not to cut so deep as to expose or damage the copper layer underneath. Starting from the end of the cable, carefully remove the outer insulation and discard.
- 3.** Carefully clean up the friction cut, removing any burrs for a neat finish.
- 4.** Fit the roll spring 20 mm ($\frac{3}{4}$ in.) from the end of the outer insulation over the exposed copper tape.
- 5.** From the end of the cable, remove the copper tape up to the roll spring, exposing the black semi-conductive material by unrolling, then tearing the tape up and back over the edge of the roll spring at about a 45° angle. (If necessary, carefully cut about 6 mm of the copper tape up against the roll spring with a knife and then tear over the spring).

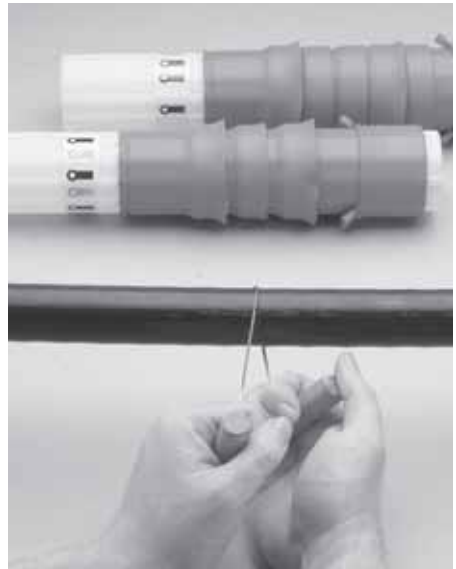

Photo 3: Use of the insulation cutting tool to cut the insulation without damaging the layers beneath.



Photo 4: Using the roll clip to cut and remove the copper screen.

6. Carefully remove the roll spring, then tape up the last 6 mm ($\frac{1}{4}$ in.) of the copper tape with a piece of PVC tape, to stop further unravelling.

7. Clean and degrease the outer sheath for a distance of 100 mm (4 in.) from the cut position. Using slight tension, wrap one layer of sealant tape (red) around the black outer insulation with a small overlap of 5 mm ($\frac{1}{2}$ in.) over the copper tape screen, (see photo 5).

8. Place the structure bond braid over the cable so that it sits over the copper screen and up against the sealant tape (red). Ensure that the braid loops are tight around the copper screen. Tape the bond braid into place with PVC tape, (see photo 6). (Ultimately, this braid may require electrical bonding to the structure.)

9. At a distance 70 mm ($2\frac{3}{4}$ in.) from the end of the cable, carefully cut a notch in triple layered insulation no deeper than 1 mm ($\frac{3}{64}$ in.). Then using the insulation-cutting tool, cut around the circumference of the triple layered insulation until the copper underneath is exposed.

10. With a knife, carefully cut along the 70 mm ($2\frac{3}{4}$ in.) length of triple layered insulation on the cable to a depth of no more than 1 mm ($\frac{3}{64}$ in.). Be sure not to cut too deep, as to expose or damage the copper layer underneath. Starting from the end of the cable, carefully remove the triple layered insulation and discard.

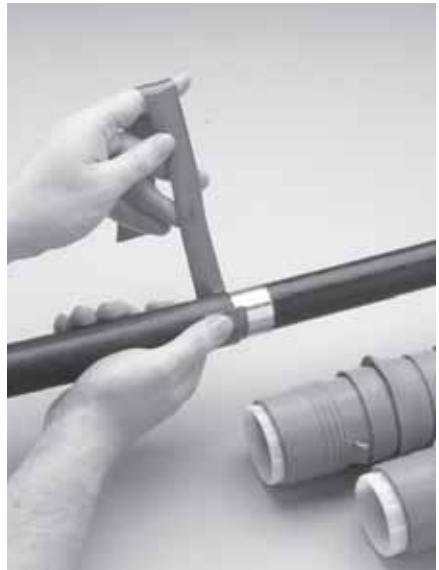

Photo 5: Red sealant tape applied over overlap.



Photo 6: Bonding braid secured in place.



11. Remove one release foil from the stress control patch (green) and apply it level with the outer insulation cut, against the red sealant tape, (see photo 7). Wrap the entire patch around the cable as shown and remove the release foil during installation. Avoid air pockets, wrinkles or creases.

12. Wrap one layer of sealant tape (red) with a small overlap and slight tension over the braid wire and previously applied sealant tape, below and level with the (green) stress control patch, (see photo 8).

13. Take apart the ERITECH® ERICORE coupling, ensuring there are 4 pieces. There should be:

- A Compression Nut
- A Compression Ring
- A Compression Cone
- A Main Coupling Piece

14. Place the compression nut and compression ring of the coupling set over the strands and copper tape layer. Check the order and orientation of the nut and ring against Figure 22 on page 36.

15. Unwrap the material double tape layer back to the compression ring. Place the compression cone between the filler core and the copper strands as shown in Figure 22. The cone should be "pushed on" until it is flush with the end of the filler core. Neatly form the copper strands back over the cone in their original order.



Photo 7: Applying the stress control patch. In line with initial outer layer cut and over the bonding braid.



Photo 8: Apply the sealant tape below the stress control patch.

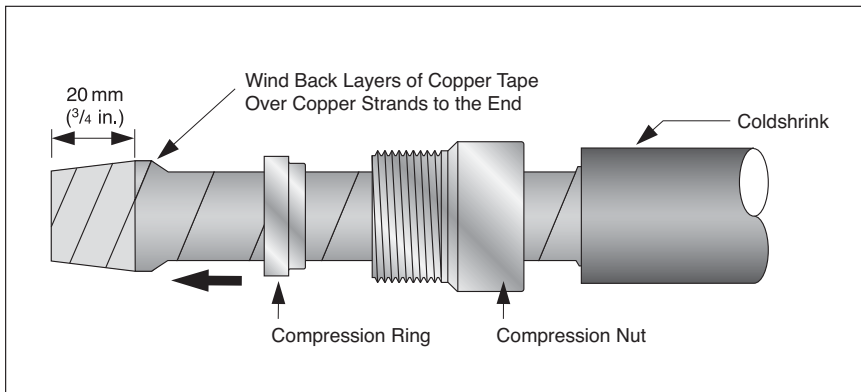

Figure 23: The termination coupling is fitted to the downconductor ready for the main coupling body to be fitted.

16. Rewrap the outer double layer of copper tape into place over the copper strands. Push the compression ring back up over the wrapped copper strands and up against the cone, (see figure 23).

17. Fit the main coupling piece from the coupling set carefully over the end of the cable ensuring the cable is pushed up as far as it will go into the coupling. Ensure the copper strands are kept in place and order. Screw the compression nut into the coupling piece and tighten, using the correct size spanners / wrenches.

18. At a distance of 100 mm (4 in.) from the end of the cable, wrap one half-lapped layer of semi-conductive tape around the triple layer insulation with an overlap towards the copper tape / copper strand center conductor up to, but not over, the compression coupling.

19. Loosening Termination

This operation is vital to the simple installation of the product.

There are two terminations in this kit, (one with three sheds, the other with five). Loosen both in the manner shown on page 33. Install the five shed termination first.

Hold the termination in one hand and the holdout in the other. Gripping firmly, twist the termination and holdout in opposite directions. Repeat twisting the termination and holdout, moving the hand in short increments up the termination until the entire termination is felt to move on the holdout. Slide the termination until it lines up with the end of the holdout tube as shown. Note: Take care not to slide the termination off the end of the holdout. Stop the termination about 6 mm (1/4 in) from the end of the holdout.



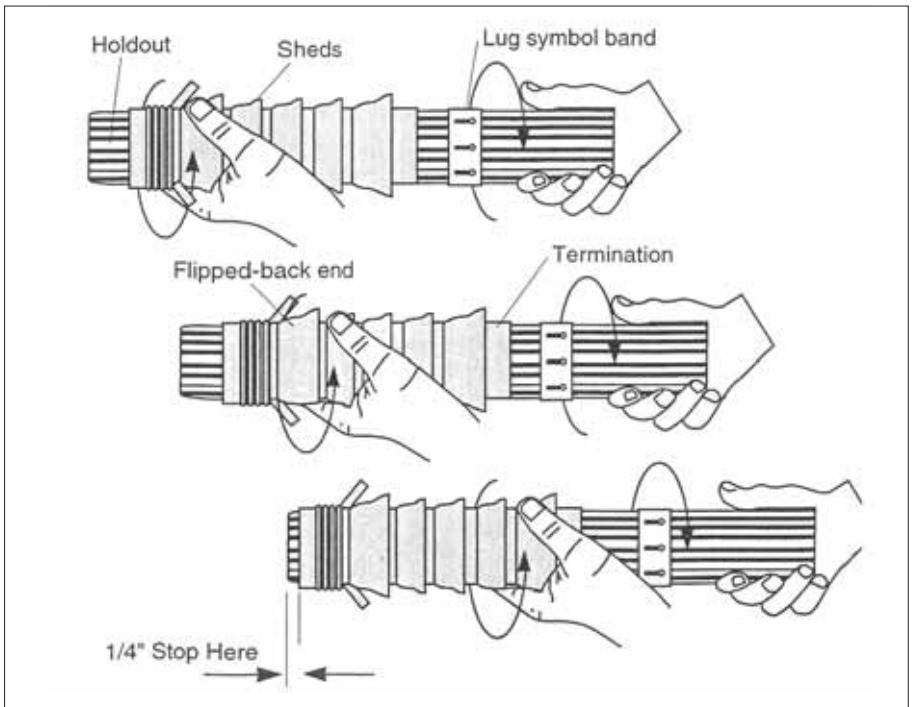

20. Installing the termination.

Position the holdout over the cable until it meets the jacket cutback. Twist the termination and slowly push it to the end of the holdout.

Slide the termination off the holdout with a twisting motion, holding the termination that is on the holdout in one hand and pulling the holdout with the other.

Note: Do NOT stretch the termination.

Do NOT hold the termination that is partially installed and attempt to pull the remaining termination off the holdout, as this will stretch the termination and generate an improperly installed termination if not repositioned.

Using the pull tabs, pull the flip-back portion away from the main termination, at the same time working the first two fingers of each hand between the flip-back and main termination. Pull the stretched out flip-back over the cable jacket and sealant.

Make sure the termination length is in accordance with the dimensions shown.

Having positioned the termination, now wrap one layer tape sealant (red) over the end of the termination and 6 mm (¼ in) onto the cable insulation as shown.

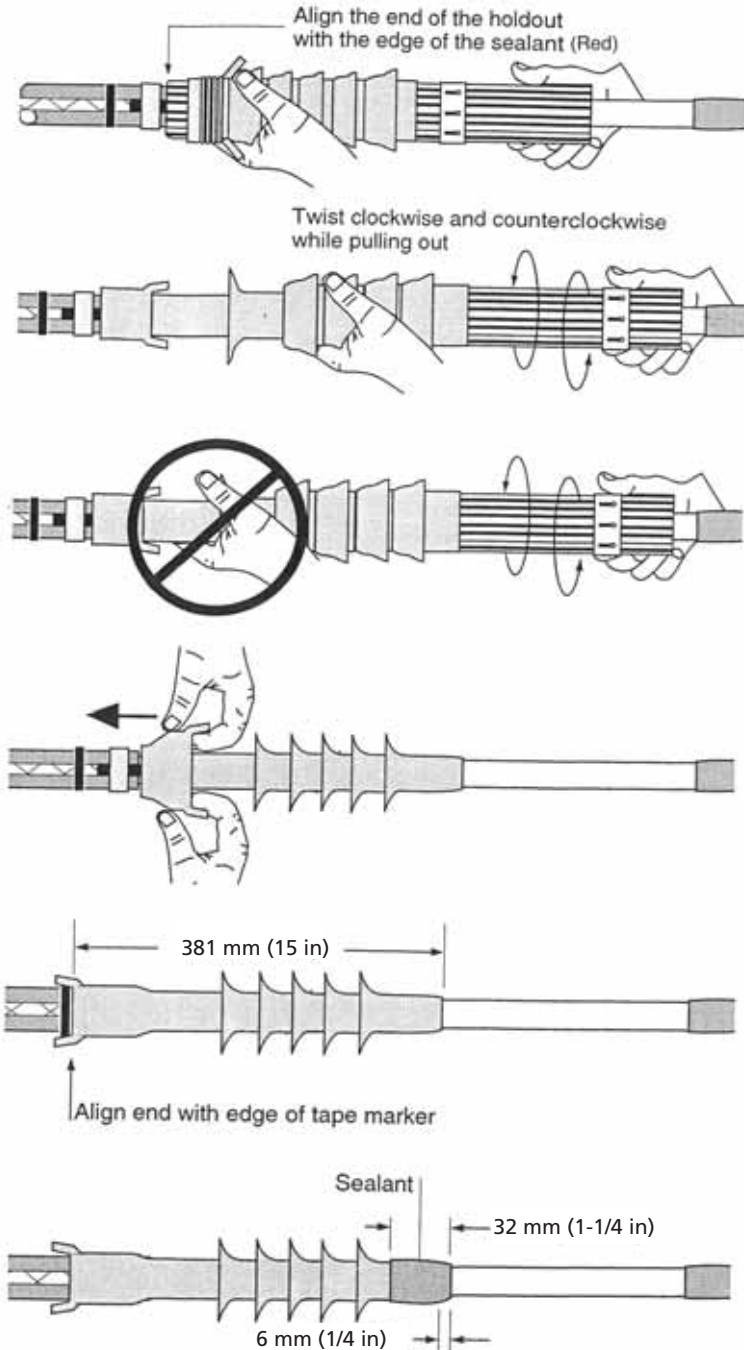

21. Installing the termination (continued).

Slide the three-shedded termination over the cable until it meets the leading edge of the sealant strip as shown. Twist the termination and slowly push it to the end of the holdout.

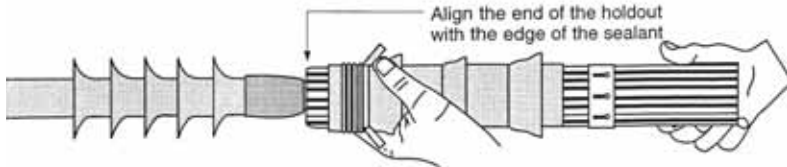

Slide the termination completely off the holdout using a twisting and pulling motion as shown.

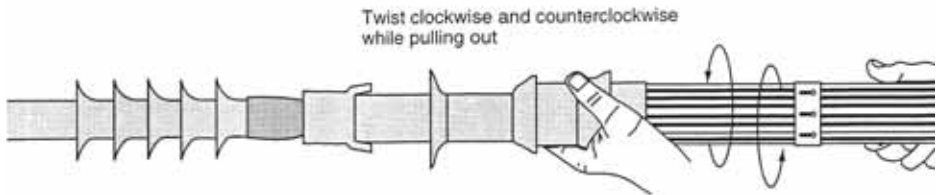

Using the pull tabs, pull the flip-back portion away from the main termination, at the same time working the first two fingers of each hand between the flip-back and main termination. Pull the stretched out flip-back over the sealant.

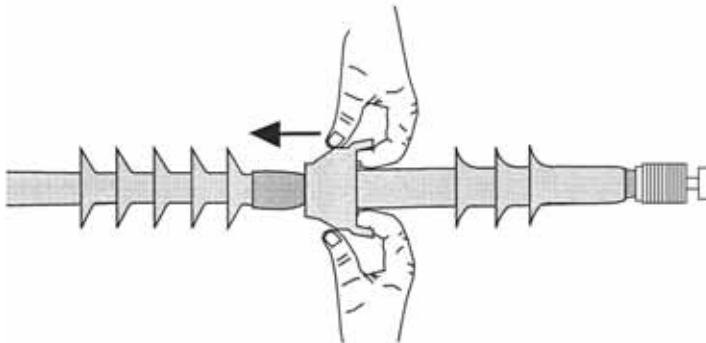

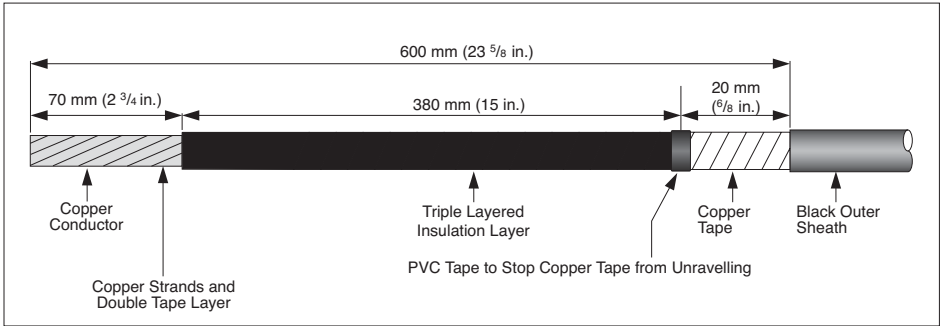

Figure 21: Cutting dimensions

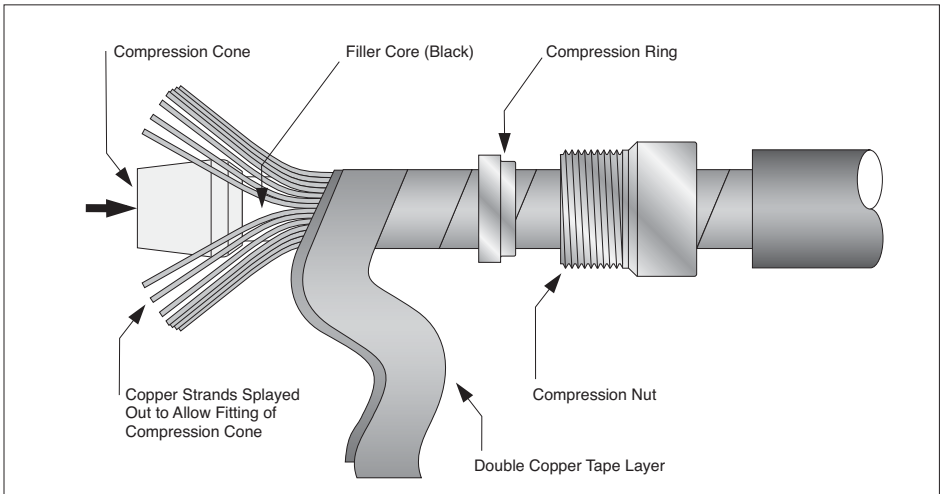

Figure 22: Positioning the compression coupling.

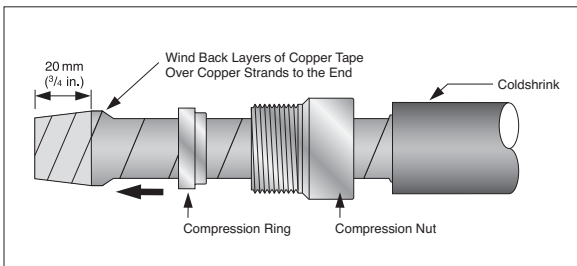

Figure 23: The termination coupling is fitted to the downconductor ready for the main coupling body to be fitted.





The coupling must be tightened using spanners / wrenches, as tightening by hands will not be adequate.

22. Using the roll of silicone tape (grey), overwrap half layers from 20 mm (¾ in.) over the end of the coldshrink to 30 mm (1 ½ in.) over the coupling so that it covers the joint between the main coupling and compression nut, (refer to figure 24 on page 39).

Wrap with moderate tension (10 to 100% stretch). Apply one final layer with no stretch. Press down, to avoid the end lifting before fusion of the tape takes place.



The finished termination must be protected against any abrasion and sharp edges during transport or installation, as the coldshrink tubes are susceptible to ripping or tearing if nicked or scuffed.

23. The structure bonding braid MUST be electrically connected via a 6 mm² (8 AWG) length of insulated copper cable to the specified conductive structural point, as

described in the ERITECH® SYSTEM 3000 Installation, Operation & Maintenance Manual.

Connecting the ERITECH® DYNASPHERE

24. Feed the downconductor (and structure bonding cable) through the FRP mast so that the entire termination is protruding from the top of the mast. Remove the lock screw in the base of the ERITECH® DYNASPHERE terminal, then screw the terminal all the way onto the termination coupling thread. Replace the lock screw back into position so that it locks the thread into place and will stop the terminal from unscrewing.

25. Carefully pull the downconductor (and structure bonding cable) back down through the FRP mast so that the terminal base sits correctly in the top of the mast. Twist the FRP mast at least one complete turn at the base of the terminal to remove any stress on the termination sheds (flanges) and to seat the terminal correctly.



Photo 11: Installed compression coupling.

Note: It may be necessary to pull back any slack of ERITECH® ERICORE downconductor through the FRP support mast to achieve a properly seated fit for the ERITECH® DYNASPHERE.

The ERITECH DYNASPHERE must not be skewed and the base of the terminal must be fully inserted into the top of the mast.

27. Place the Vital Warning Label in a prominent position at the base of the mast, or beside the downconductor at eye level, if the installation is in an area where it is possible for persons to gain access.



These termination procedures should be strictly adhered to since an incorrect termination will result in failure of the system.

26. Connect the 6 mm² (8 AWG) structure bonding cable as detailed in the ERITECH® SYSTEM 3000 Installation, Operation and Maintenance Manual. After bonding the cable, ensure that the connection is waterproof and resealed if required.



Photo 12: Completed termination.

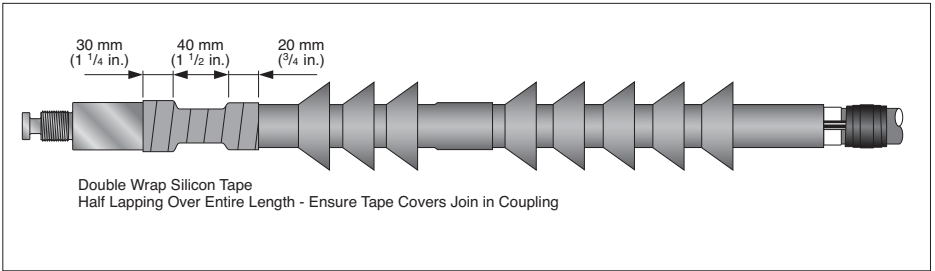

Figure 24.



Photo 13: Once the ERITECH® DYNASPHERE has been fitted to the termination coupling, ensure the locking screw is tightened securely.



Photo 14.

Terminals and Masts

Terminals

Once the terminal has been checked and found to be in an acceptable condition for installation, it can be attached to the terminated downconductor as shown in the Upper Termination instructions on page 37.

Please note, the serial number of each unit will have been recorded in the Certificate Of Compliance (inside back cover) in this manual.

Masts

The selected mast configuration chosen must:

- Elevate the terminal to the required height as determined by the design process (minimum height of 3 m (10 ft.) above the highest point of the structure).
- Include a minimum of 2 m (80 in.) of insulated mast material (FRP) immediately below the air terminal.
- Be suitably rated for local weather conditions. It is advisable that guidance from a local civil engineer be sought.
- Be securely attached to the selected mounting point(s).
- Be guyed if applicable.



If the lower section of the mast is conductive, ie. aluminum or galvanized iron; then:

- *It must be electrically bonded to the nearest conductive structural point. This may be either structural steel work or concrete reinforcing. Refer to page 20 for details.*
- *The downconductor must be secured to the mast at 1 m (40 in.) intervals (max.).*

Three basic types of mast configuration include:

Guyed

- Single length guyed - one section of FRP (Fiberglass Reinforced Plastic) mast material guyed at the top.
- Double length guyed - two sections of mast material, usually aluminum lower and FRP upper, guyed between the two sections and at the top.

Cantilevered

Used in situations where it is more practical to mount without a base, eg: radio towers.

- At least one third of the lower mast should be secured against the structure.
- Cantilevered masts can either be free standing or guyed for extra stability.

Freestanding

Often used where the terminal, downconductor and grounding system are isolated from volatile areas by installing the ERITECH® SYSTEM 3000 at least 5 m (17 ft.) away from those areas.



Before the installation of the mast, ensure that:

- The free standing mast is supplied with an appropriate spigot, suitable for either internal or external mounting of the FRP mast.
- The downconductor is to be routed internally or externally.
- Provision is made for external or internal mounting of LEC IV and access.
- The downconductor is able to exit through the base of the free standing mast.

The free standing mast requirements for foundations and erection are generally handled by the mast manufacturers.

Mast Bases

ERICO supplies a range of aluminum bases to suit:

- ERITECH® brand of FRP masts (aluminum base with an internal mast spigot).
- Aluminum masts (welded directly onto the required length of mast).

Both base types have downconductor exit holes in the base, required if the downconductor is to be routed inside of the mast. They also have identical mounting hole dimensions which are shown overleaf.

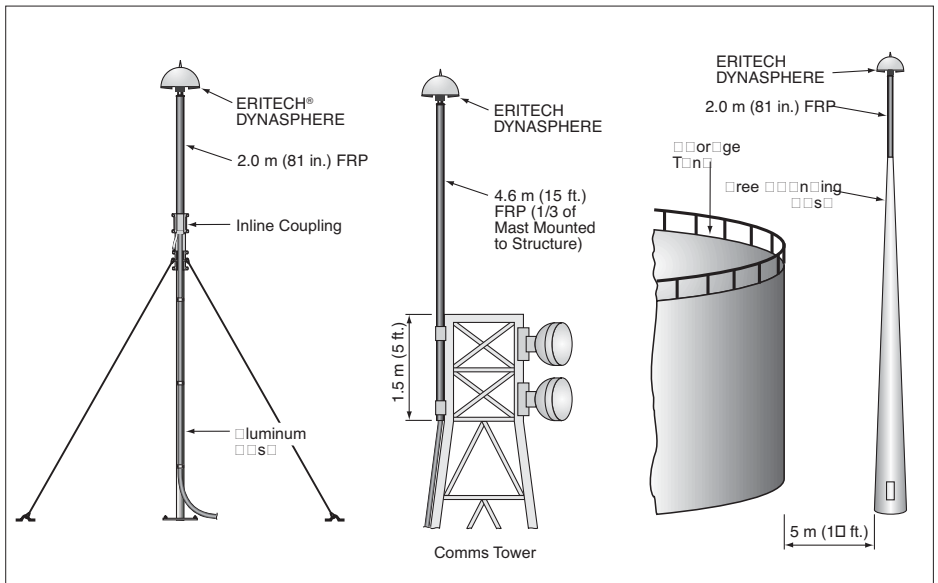

Figure 25: Guyed, Cantilevered and Free Standing Mast examples.

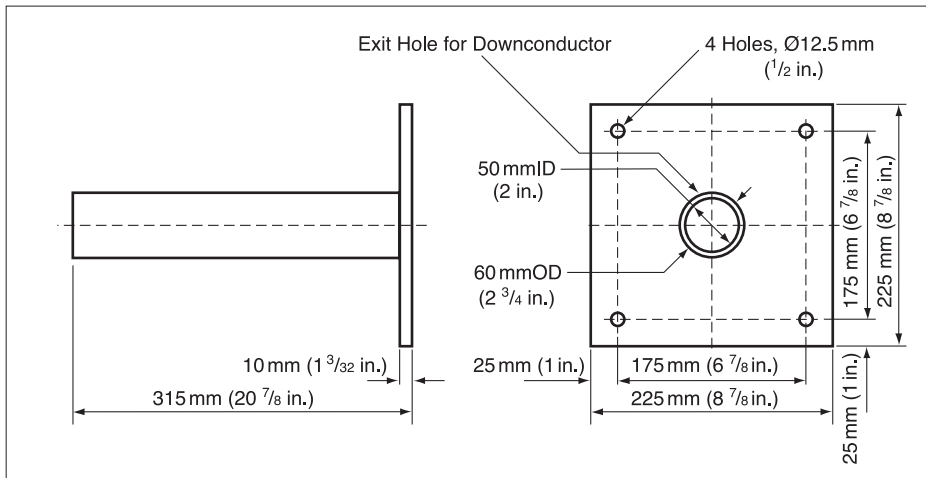

Figure 26: Base and mounting dimensions.



If an aluminum mast and base are used and can not be directly attached to the structural steel work, or are anchored to a concrete roof, then they need to be directly electrically bonded to the closest structural steel work or conductive structural point. Refer to page 20.

Mast Couplings and Guying Points

There are two different methods of coupling two sections of mast:

1. The U-Bolt set, which uses two stainless steel U-bolts to clamp the two sections of mast together, (see figure 28).
2. The Inline Coupling is designed to fit between the upper and lower sections of the masts and also provides three guying anchor points, and, a down-conductor exit point if required. The maximum mast diameter that the Inline Coupling is able to clamp onto is 70 mm (2 7/8 in.) OD.



On both the U-Bolts and Inline Couplings, the nuts must not be tightened to any more than 55kg/cm (45 in.lb).



Additional guying is required at the top of 4.6 m (15 1/2 ft.) FRP masts (if not mounted in a cantilevered fashion). A guying ring is supplied for guy anchor points. This is installed between the ERITECH® DYNASPHERE terminal and the top of the mast, (see figure 27).



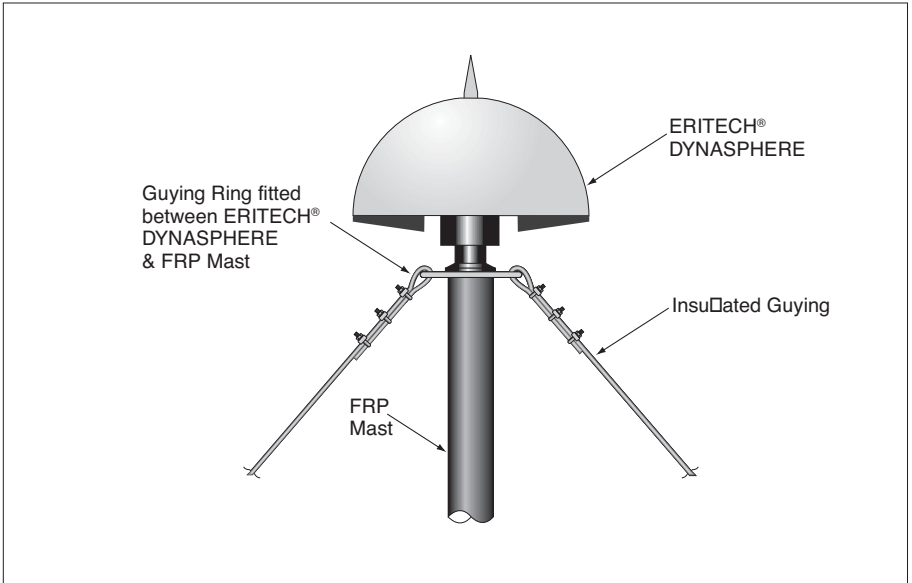

Figure 27: Use of Guying Ring.

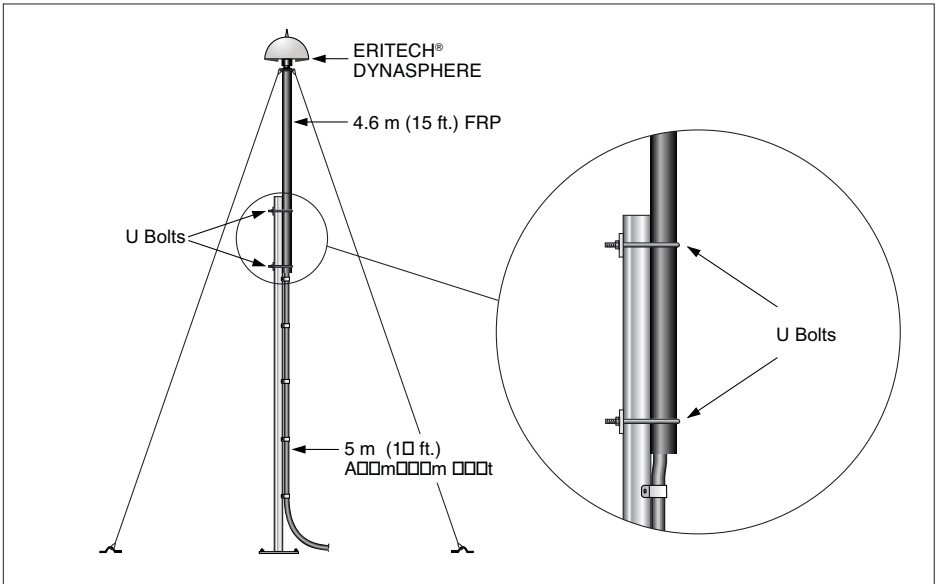

Figure 28: Use of U-Bolts.

Guying

ERICO has standard 4 m (13 ½ ft.) and 7 m (24 ½ ft.) guying kits. If the guying of a fiberglass mast is required, then the appropriate guying kit should be selected to suit the application. The guying material is made up of light weight plastic coated fiberglass, which is non-conductive.

If a customized guy kit has been supplied, then the actual guy length can be determined from the following:

$$\text{Guy Length} = 1.41 X$$

Where X = the vertical height between the upper and lower guying points and the assumed angle from horizontal is 45°.



Important recommendations:

- When guying any mast, it is advisable that the guying angle be no greater than 60° from horizontal.
- It is recommended that 8 mm (5/16 in.) diameter stainless steel guying saddles are used for the base guy anchor points. If these are to be anchored to a concrete surface, then 6 mm (¼ in.) diameter x 40 mm (1 5/8 in.) depth (minimum) masonry anchors or similar should be used.

- Each of the guying kits comes with six stainless steel thimbles to relieve stress on the guys at the anchor points. These thimbles **MUST** be used when guying, (see figure 29).
- When using shackles (5 mm (3/16 in.) minimum), ensure that the shackle pins are secured with nichrome wire.

When securing the fiberglass guys, use the guying grips supplied in the guying kit, carefully following the instructions provided. Use of alternative wire rope grips is acceptable but ensure that:

- Grips are made of a suitable material to PREVENT corrosion.
- There are a minimum of 3 grips per guy end.
- Grips are spaced at a minimum of 30 mm (1 ¼ in.) on guys (or 6 x guy diameter).
- Grips are correctly orientated - grip base (saddle) on the 'Live' side of the guy and 'U-bolt' over the 'Dead' side or tail of the guy.
- No more than 60 cN.m (5 lbf.in) of torque is applied to the grip.

The above recommendations should also be used for any other guying, ie: stainless steel, when used on any mast.

Guy Kit Specifications

Guying Kit	Guy Diameter	Actual Guy Length	Guy Tensile Strength
4 m Guy Kit	4 mm - 5/32 in.	6 m - 20 ½ ft.	430 Kg - 946 lb
7 m Guy Kit	5 mm - 3/16 in.	10 m - 34 ft.	560 Kg - 1232 lb



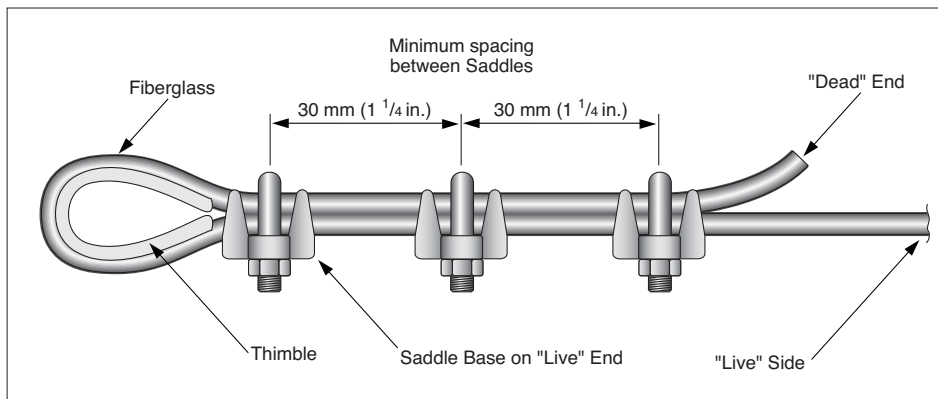

Figure 29: Correct methods of guying.

Raising of Mast

When ready to raise the mast, check the following:

- Guys to the inline coupling, guying ring or other mast anchor points are properly secured.
- Ensure the guys are not twisted, kinked or damaged in any way.
- Ensure that each guy can be easily secured at the base when the mast has been raised.

Turnbuckles or rigging screws are recommended at the base anchor points of the guys to enable easy vertical alignment of the mast and correct tensioning of the guys. If using turn-buckles, ensure that they are wired securely with nichrome wire.

Using conductive guying, such as stainless steel, is acceptable as long as it is NOT used for guying to the top of sections of insulated FRP mast. Guying to the top of an aluminum section of mast is acceptable.

Remember to always Plan the Lift before attempting it.

If the mast is to be raised by hand, ensure that it can be safely and easily managed manually.

It is recommended that the use of a crane or other suitable equipment be used for anything over 6 m (20 ft.) in height, or for hazardous area installations such as high elevations (towers).

To minimize the possibility of the mast becoming bent or damaged, it is very important to keep the mast straight during the lift.

Ensure that:

-  There are no overhead AC power lines.
- There is nothing overhead that will obstruct the lift.
- There is enough man-power available to safely conduct the lift.
- There is only ONE person in control of the lift.

- Everyone involved in the lift knows what has been planned and how the lift is to be performed.
- The mast is securely footed and cannot move out of control during the lift.
- Any guying has been properly secured at the mast anchor points.
- The downconductor has been correctly terminated and the structure bonding cable has been attached to the termination.
- The downconductor can not be damaged at the base of the mast while lifting, ie: if the cable exits from the mast base it must be protected and not used as the pivot point for the mast. Maintain a minimum bending radius of 500 mm (20 in.).

- The mast can be easily and safely secured at the base and guying points immediately after it has been lifted into position.
- Any extra rigging that is required for the lift only, can be removed after the mast is in place.

It may be necessary to use a gin pole arrangement to assist when lifting the mast, especially if the mast is over 6 m (20 ft.) in height or it is being lifted from a sloping surface (typical arrangement shown below).

When using a crane to lift the mast into position, ensure that:

- The crane has enough weight and height capacity to safely do the job.
- There is nothing overhead that will obstruct the lift.

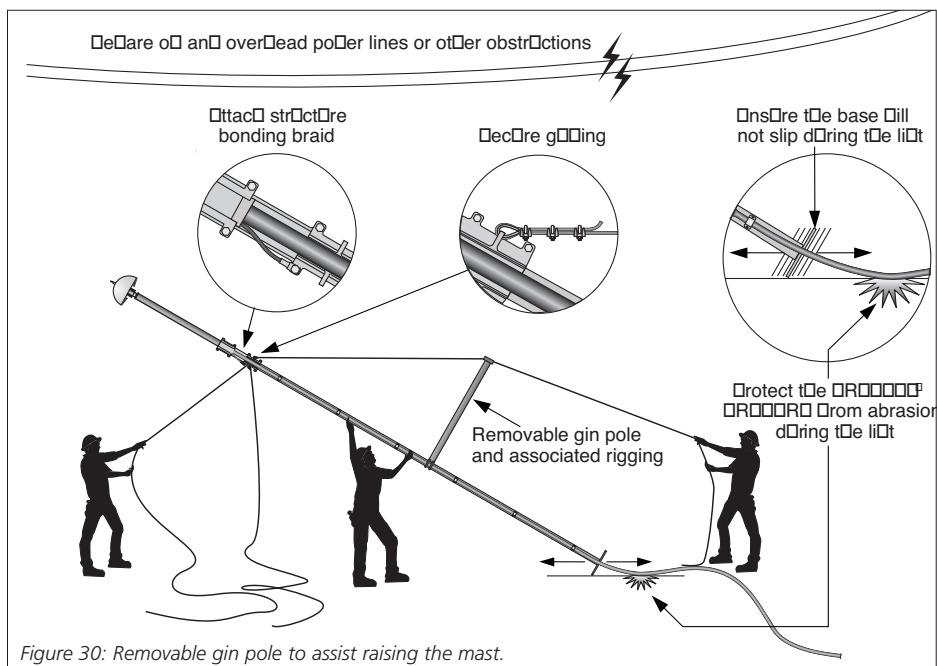

Figure 30: Removable gin pole to assist raising the mast.



- Any guying has been properly secured at the mast anchor points.
- The downconductor has been correctly terminated and the structure bonding cable has been attached correctly.
- The ERITECH® DYNASPHERE terminal is NOT used as a slinging point.
- When slinging the mast, ensure that the slings or ropes can not foul the ERITECH DYNASPHERE terminal.
- When lifting the mast, the downconductor is tied off to the mast as well to remove any strain on the down-conductors termination to the ERITECH DYNASPHERE terminal.
- The downconductor can not be damaged at the base of the mast while lifting (maintain a minimum bending radius of 500 mm (20 in.)) or can not be damaged as a result of dragging over rough or sharp surfaces during the lift.
- Any extra rigging that is required for the lift only, can be removed after the mast is in place.
- The mast can be easily and safely secured at its base and guying points when it is lifted into position.

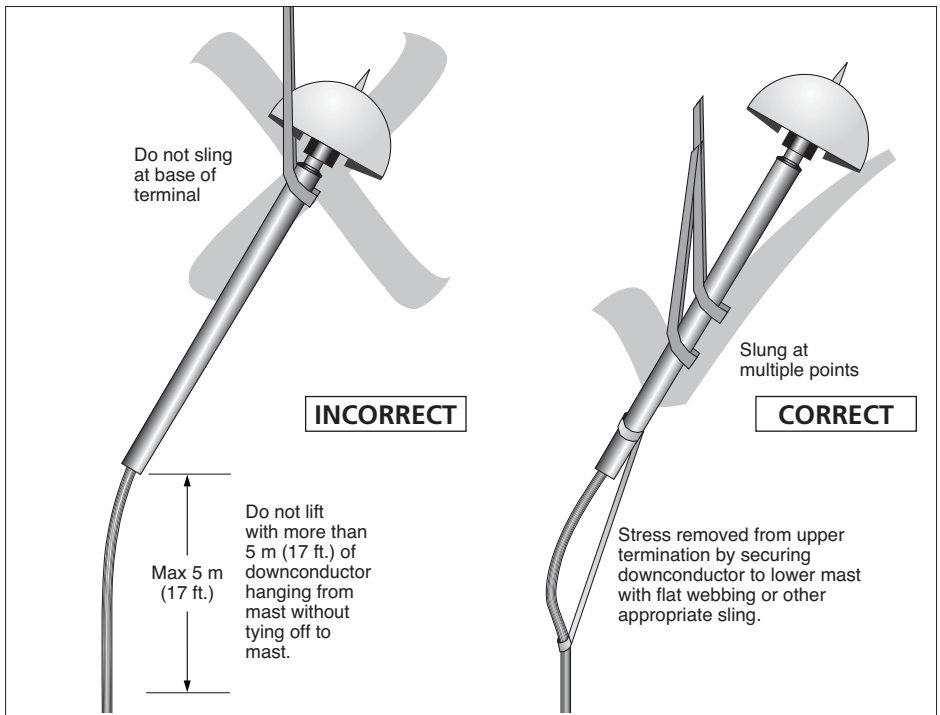

Figure 31: Incorrect and correct hauling methods.

Lightning Event Counter (LEC)

The LEC IV can be mounted at any point on the downconductor or at the injection point of the grounding system.

Refer to the instructions supplied with the LEC IV when installing the unit.

When mounting the LEC IV, ensure that:

- It is mounted in a secure area that is not prone to contact with moving objects, theft or vandalism.
- It is not mounted in an area that is prone to flooding.
- The display can be easily viewed if the LEC IV is mounted vertically and is encased in a separate enclosure.

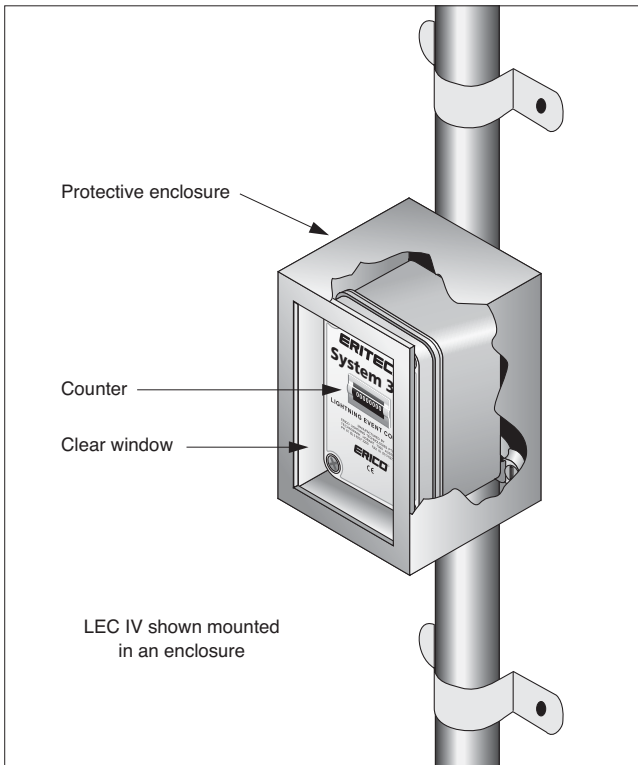

Figure 32: LEC IV in protective enclosure with clear viewing window, for easy counter reading.



Long Lengths of ERITECH® ERICORE Downconductor

Most installations can be conducted with a single ERITECH® ERICORE downconductor cable as described earlier in this manual. However, where the installation involves a long single length of ERITECH® ERICORE cable, additional measures may need to be taken to help ensure that the voltage build up on the cable during a lightning strike will not be excessive.

Before considering these measures, it needs to be determined if the cable is too long to run in a single uninterrupted length. The flowchart in Figure 33 allows this to be determined. Starting with the proposed ERITECH® ERICORE length as indicated in the LPSD design, follow the chart to the appropriate outcome. If a single length of ERITECH ERICORE is acceptable, no further consideration is required.

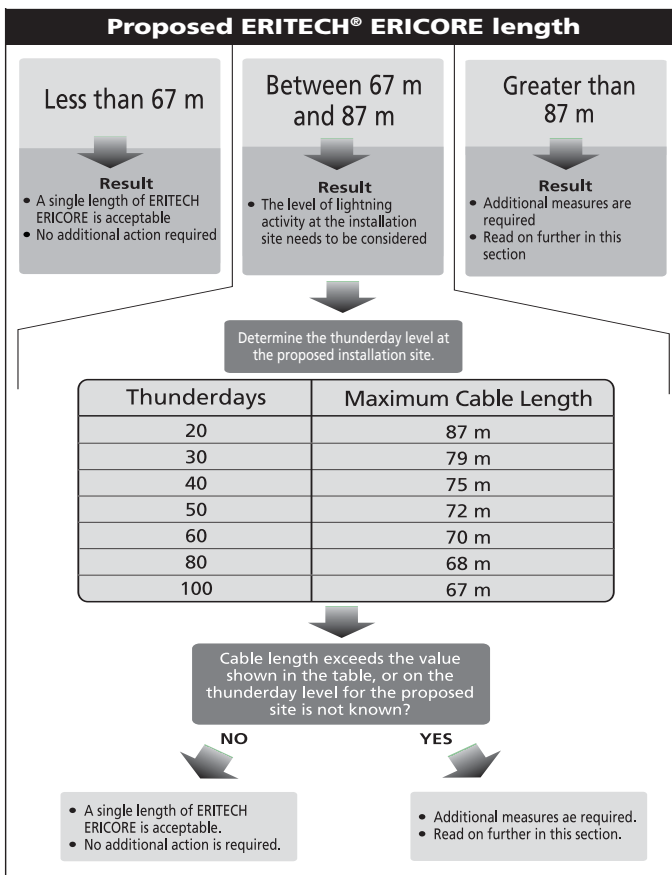

Figure 33: Determination of maximum single ERITECH ERICORE length.

However, if the result indicates that additional measures are required, then a single uninterrupted length of ERITECH® ERICORE cannot be run.

Although the flowchart allows lengths of up to 87 m, ideally lengths should be limited to 70 m to avoid any likelihood of problems.

When determining the apparent length of ERITECH® ERICORE conductor required in a particular situation it is prudent to make the connection to the ground system at the first available opportunity. The practice of running ERITECH ERICORE for long horizontal lengths at the ground level to reach a designated earth point is discouraged. Instead a lower termination should be made to a suitable earthing point upon reaching the ground or basement level, then a separate length of conventional grounding bonding conductor run to other earthing points as required.



In the case of installations exceeding the maximum single ERITECH ERICORE cable length, the advice of the ERICO application engineering group should be sought. The following information on the techniques used is intended as a guide for installers and to provide background information.

Note: If the number of thunderdays for the proposed installation site is not known, but the ground flash density is known, this value can be converted to thunderdays using the following table. This resulting value can then be used in the figure 33.

When additional measures are required, there are two basic approaches to reducing the otherwise unacceptable voltage rise that would occur on the cable:

- Run parallel ERITECH ERICORE cables,
or
- Run a single ERITECH® ERICORE cable, but break it into several sections, none of which exceeds the cable breakdown voltage. This is done by periodically connecting the cable to a conductive structural point.

These methods are explained as follows.

Ground flash density (strikes / km ² / year)	Lightning activity (thunderdays / year)
Up to 2.7	20
2.8 to 3.9	30
4.0 to 5.2	40
5.3 to 6.6	50
6.7 to 9.5	60
9.6 to 12.5	80
12.6 or more	100



Parallel ERITECH® ERICORE cables

Running two or more parallel cables reduces the voltage rise on each cable by reducing the current magnitude flowing in each cable. For example, if three cables were run in parallel, each cable could be three times the single length. In practice, however, this technique is generally only economically viable when running two cable sections in parallel. ERICO has developed a special hardware arrangement to allow this to occur, as illustrated in Figure 34.

The dual coupling termination allows the ERITECH® DYNASPHERE air terminal to connect to two ERITECH® ERICORE cables, each complete with upper terminations and FRP masts. All the rules that normally apply to a single ERITECH ERICORE arrangement apply to these two cables and mast arrangement.

A typical mast arrangement is shown in Figure 35. The normal u-bolts are used to fix the FRP masts to the aluminum mast, and the conductive saddles are used to fix the ERITECH® ERICORE to the mast at the normal interval of at least every 1 meter (40 in.). Note that the center mast and the two FRP sections will not be completely in line when the FRP masts are correctly spaced.

Depending on the mast height required, either the 2 meter, or the 4.6 meter, FRP mast may be used.

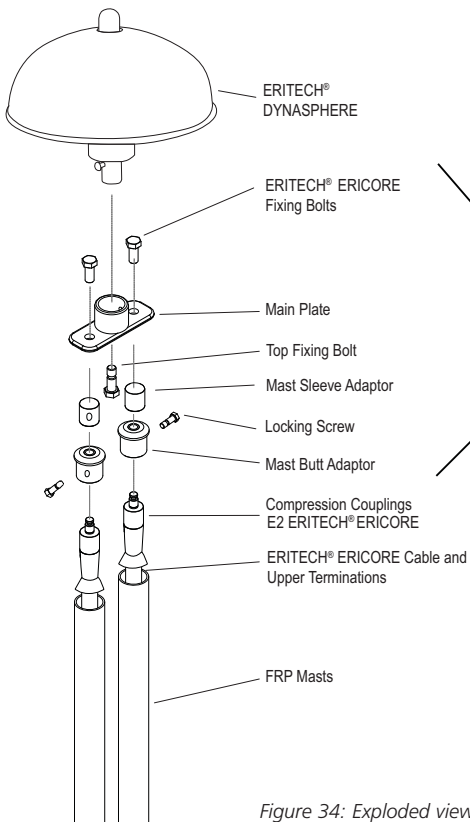

These items are only included in item 'TERMDUALCOUP', remaining items are shown for field assembly purposes only.

Figure 34: Exploded view of the Dual Coupling Termination.



IMPORTANT – To maintain the necessary clearance between the ERITECH® DYNASPHERE air terminal and the top of the mast, the FRP mast must protrude **at least 1400 mm** above the top of the aluminum mast. The following shows the required positioning dimensions for the two available FRP mast sizes.

2 meter FRP Mast

Overlap on aluminum mast = 600 mm
 Protrusion above aluminum mast = 1400 mm

4.6 meter FRP Mast

Overlap on aluminum mast = 1.5 m
 Protrusion above aluminum mast = 3.1 m
 The standard guy ring part may be fitted to the Dual Coupling Termination and used with the usual guying kit.

The twin ERITECH® ERICORE conductors are run in a parallel manner down to ground (see Figure 36). The usual conductive saddle spacing applies.

At the point of connection to the grounding system, each ERITECH® ERICORE cable is fitted with an ERITECH ERICORE lower termination kit, and attached to the grounding system

Series connected ERITECH® ERICORE cable sections

As an alternative to running twin ERITECH ERICORE conductors, a single ERITECH ERICORE cable can be run, but it is broken into several sections, none of which exceeds the cable breakdown voltage. This is done by periodically connecting the cable to a conductive structural point (see Figure 37).

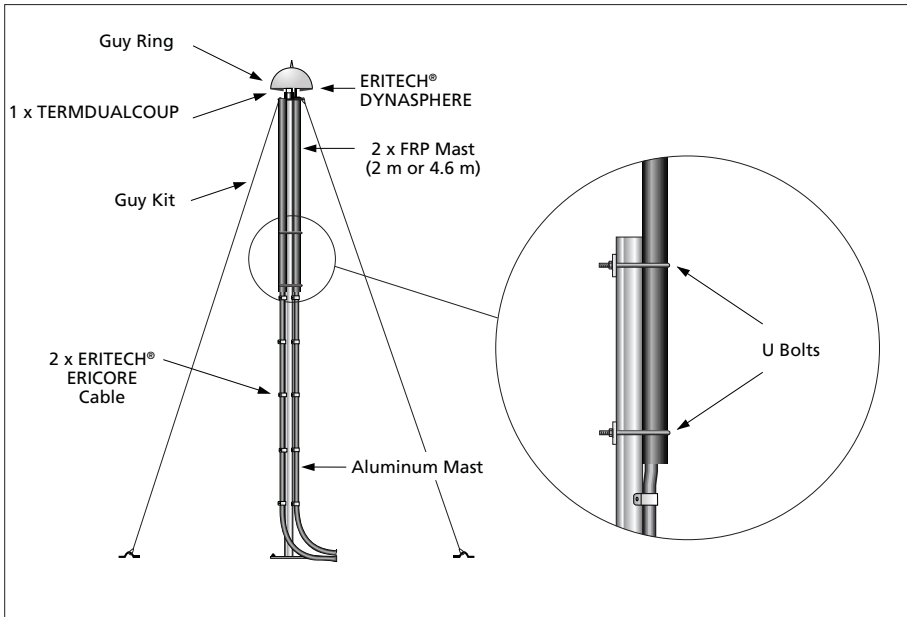

Figure 35: Typical mast arrangement using the twin ERITECH® ERICORE arrangement.



The lower end of the upper cable section is fitted with a lower termination, and the upper end of the lower cable section is fitted with an upper termination. The lower termination inherently has a lug termination, but the upper termination needs to be fitted with a bonding termination (ERICORE/UTSP) and lug (termplugcoup) to allow it to be lugged. Each of these two lugged terminations must be electrically bolted together and to a suitable conductive structural point.

In some installations, both lugs can be directly connected to a suitable conductive structural point, but in some installations it will be more convenient to connect both lugs to a small busbar, and have this busbar connected to a suitable nearby conductive structural point. Note that the conductor used in this case must be a minimum of 16 mm² (4 AWG) and should not exceed 5 m (200 in) in length. A suitable conductive structural point may be either structural steel work or the reinforcing within concrete panels or slabs.

These joints should not be exposed to the weather and are usually located in a service shaft. Very tall buildings will have a number of connection points depending on their height.

Details of where to provide the joint will be provided by the ERICO application engineers, after consideration of the building details.

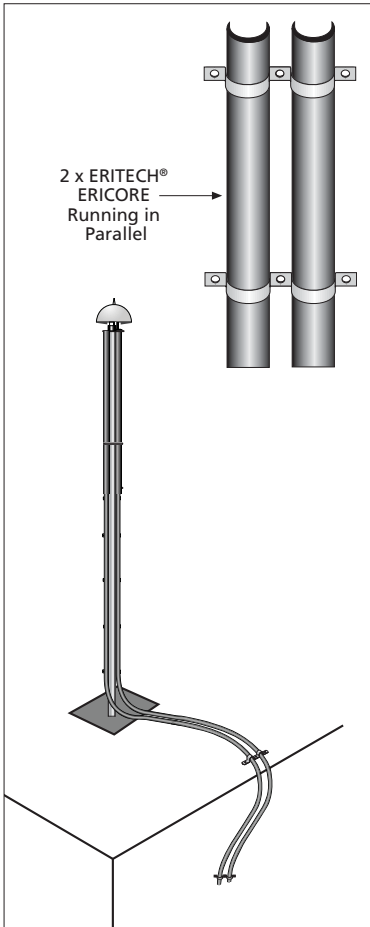

Figure 36: The twin ERITECH ERICORE conductors are run parallel down to the ground.

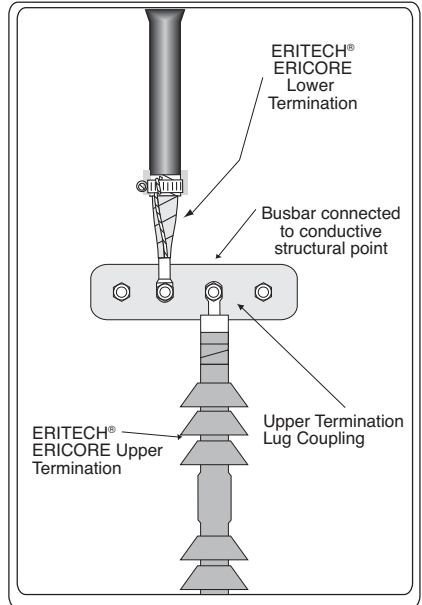
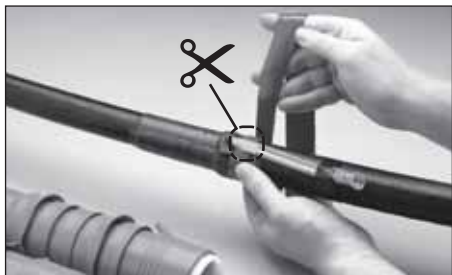

Figure 37: The method of joining ERITECH ERICORE sections.

Removal of Structural Bonding Braid



The upper terminations on all lower sections of ERITECH® ERICORE cable are to have the structural bonding braids removed. The following diagram indicates how this is done. The cold shrink is rolled back as far as possible, and the structural bonding braid

cut off as far back as possible. Then the coldshrink is rolled back in place, covering the freshly cut braid. Discard the cut off braid and terminal block.

Alternative attachment of upper termination to busbar

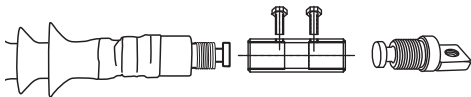

If an upper termination lug coupling is not available, a TERMLUGCOUPL may be used in conjunction with a coupling tube (part: ERICOREUTSP) as shown here.

Practical examples for Long Lengths of ERITECH® ERICORE

When to use a twin ERITECH® ERICORE arrangement or a series connected arrangement depends on the particular circumstance. The following examples give typical guidance.

Telecom Towers

Most towers would be less than 70 m, or so, in height so that a single ERITECH® ERICORE downconductor would suffice. However, where the tower is over the maximum single length but less than twice the maximum single length (typically 70 m (230 ft) to 140 m (460 ft) in height), it is preferable to run twin ERITECH® ERICORE downconductors. These conductors should ideally run down opposite legs of the tower and each connect into the ring earth at the base of the tower.

Alternatively, and less preferably, a single upper section of typical length 70 m (230 ft) could be run from the top of the tower to a point lower down on the tower, then bonded to the tower using a waterproofed lower termination. A conventional lightning downconductor could be run from this point down to the base of the

tower. This arrangement helps ensure that the lightning current bypasses the sensitive tower mounted electronics mounted in the antennas on the top half of the tower.

Buildings

Buildings less than 70 m (230 ft), or so, in height are served by a single ERITECH® ERICORE downconductor.

Buildings of height over the maximum single length but less than twice the maximum single length (typically 70 m (230 ft) to 140 m (460 ft) in height) may be installed with either twin ERITECH® ERICORE down-conductors, or a series connection in the service shaft.

Buildings of height greater than twice the maximum single length (typically greater than 140 m (460 ft) in height) need to use the series connection method. The ERICO application engineering group will determine the allowable lengths of the lower cable sections, which may be able to be longer than the upper length, and in some cases, the lower sections may be conventional downconductor.



Certification

The certification of the ERITECH® SYSTEM 3000 installation must be performed by an authorized ERICO representative.

This is done in conjunction with issuing of a Certificate of Compliance, which is supplied in the back of this manual.

When this certificate has been completed and signed, a copy must be either taken by the ERICO representative or sent to the nearest ERICO office.

During the process of certification, the following will be checked:

- Installation matches the originally approved design.
- Installation needs to be registered at www.erico.com.
- The integrity of the mast and any associated brackets and fastenings.
- Guying, anchor points and fastenings.
- Downconductor routing, securing and seals.
- Ground termination of downconductor.
- Grounding System.
- Labelling.
- Completion of Maintenance Records in this manual.
- Certificate of Compliance and web site registration completed.
- General mechanical check of all fastenings.

Operation and Maintenance

The ERITECH SYSTEM 3000 lightning protection system requires no user operation and is completely automatic in operation.

- The ERITECH® DYNASPHERE becomes active only during storm activity.
- The system does not require any external power requirements or replacement components for normal operation.
- It is essential that the ERITECH SYSTEM 3000 Lightning Protection System be regularly maintained.

Maintenance should be undertaken:

- After each known strike to the ERITECH DYNASPHERE.
- At least once per year.
- If any changes have been made to the structure, whether they be structural, antennae or building maintenance unit additions, etc.

Use the maintenance record table on page 58 to record the relevant details. These records and manual should be kept in a safe place near the installation.

Maintenance should be undertaken as follows:



Do not attempt maintenance during potential lightning periods.

1. Check that the building is the same physical shape and that no additional structures such as antennae, advertising signs, satellite dishes, building maintenance units or similar have been installed within 3 m (121 in.) height of the ERITECH® DYNASPHERE.
2. Inspect the ERITECH DYNASPHERE to ensure that it is not dented or physically damaged in any way.
3. Inspect the finial tip on top of the ERITECH DYNASPHERE to ensure that it is not excessively burnt, deformed or missing. A finial tip must be replaced if more than 6 mm (¼ in.) of the tip is missing.
4. Check that the FRP mast and lower mast assembly is securely attached to the structure. Check that the guys are secure and undamaged. Replace if necessary. Check that all fastenings are secure and tight.
5. If connected, check the structure bonding cable from the upper termination or mast base is securely connected to the structural steel work.
6. Look for signs of damage to the ERITECH® ERICORE downconductor (whether by lightning, careless handling, vandalism or other causes). Check that the downconductor is inaccessible to people and machinery.
7. Check that all labels and signs are still attached and clearly legible. These labels MUST be in place. Refer to the section on Labelling.

8. Check that the Lightning Event Counter (LEC) is secure, and that the display is registering a reading, then record the reading.
9. Record resistance and continuity measurements using figure 38 and the table on page 57.

These measurements should be performed after a known strike to the terminal.

- Remove the waterproofing mastic from the lower termination to expose the connection.
- Disconnect the downconductor from the grounding system.
- If possible, disconnect the structure ground bonding cable from the grounding system.
- Measure the ground resistance of the lightning protection grounding system and record in column 1 of ground resistance readings.
- Measure the ground resistance of the structure and record in column 2 of ground resistance readings.
- Reconnect the structure ground bonding cable to the lightning protection ground system, then measure & record in column 3 of ground resistance readings.
- At the lower termination of the downconductor, disconnect the 2.5 mm² (12 AWG) bonding wire from under the hose clamp.
- With a multimeter, measure the continuity between the center conductor and the copper screen of the downconductor. (This should be greater than 1,000 ohms).



- If possible, measure the continuity between the center conductor at the lower and upper end of the downconductor, (this should be low ohms).
- Reconnect the 2.5 mm² (12 AWG) bonding wire to the hose clamp.
- Reconnect the downconductor lower termination and structure ground bonding cable to the lightning protection grounding system.
- Reseal the lower termination and grounding connection in waterproofing mastic and ensure that the whole connection is made waterproof.

10. Report any problems, defects or inconsistencies to your nearest ERICO Distributor.
11. ERICO maintains a database of statistical information concerning ERITECH® SYSTEM 3000 installations. We encourage copies of the initial maintenance records be sent to ERICO for collation into our database.

These records should include:

 - Name and location of the structure
 - Installation date
 - Building height
 - Maintenance inspection date
 - Latest lightning event counter reading
 - The Certificate of Compliance

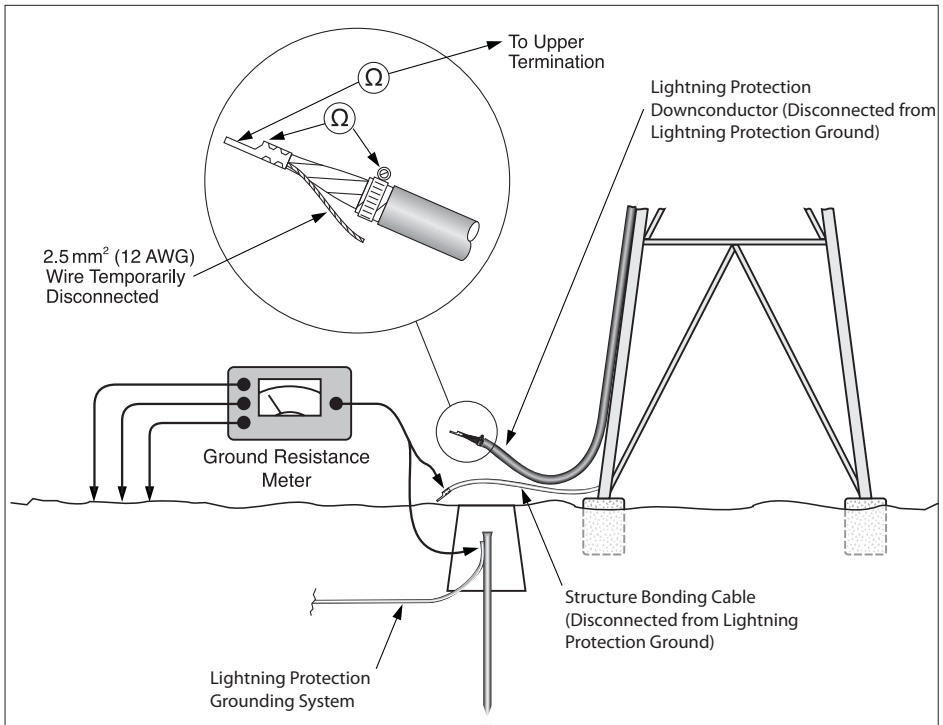



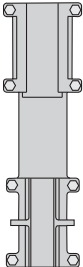

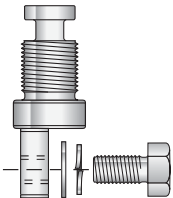



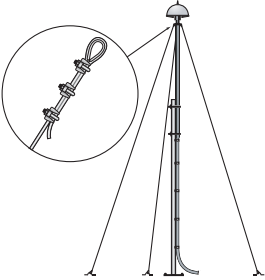
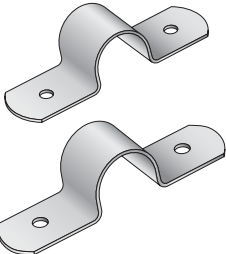

Figure 38: Grounding and downconductor continuity testing.

Specifications

	<p>ERITECH® DYNASPHERE Enhanced Terminal</p> <p>Capture point of the ERITECH® SYSTEM 3000. Initiates an upward leader during storm conditions to attract lightning discharges over a greater radius than conventional protection.</p> <p>Height: 140 mm (5 1/2 in.) Diameter: 255 mm (10 in.) Weight: 2.8 kg (6 lbs.) Color/Finish: Brushed Stainless Steel</p>
	<p>ERITECH® ERICORE Downconductor</p> <p>Purpose designed cables, using a copper 50 mm² (1/0 AWG) main conductor to safely convey the lightning energy to ground, while minimizing side flashing.</p> <p>Diameter: 36 mm (1 7/16") Weight: 1.2 kg / m 13 oz / ft.</p>
	<p>FRP Mast</p> <p>Purpose designed Fiberglass Reinforced Plastic, manufactured from non-hydroscopic epoxy and glass laminate, provides an insulated mast for mounting the ERITECH® DYNASPHERE.</p> <p>Lengths: 2 m (81 1/2 in.) & 4.6 m (187 3/4 in.) Inside Diameter: 60 mm (2 3/8 in.) Outside Diameter: 68 mm (2 11/16 in.) Weight: 2 m = 3.3 kg (7 1/4 lbs.) 4.6 m = 7.6 kg (16 3/4 lbs.) Color/Finish: Black</p>
	<p>Aluminum Mast</p> <p>Light weight lower mast material.</p> <p>Lengths: 3, 4, 5 & 6 m (122 1/2, 163 1/4, 204 & 245 in.) Inside diameter: 61.9 mm (2 7/16 in.) Outside diameter: 69.9 mm (2 3/4 in.) Weight: 2.4 kg / meter Available with or without mast base plate.</p>

	<p>Inline Coupling</p> <p>Purpose designed coupling to clamp FRP to aluminum lower mast, providing 3 guy anchoring points and downconductor exit point.</p> <p>Max. Clamping diameter: 70 mm (2 ⁷/₈ in.) Max. Clamping torque: 55 kg/cm (45 in.lb.) Weight: 2.4 kg (5 ¹/₄ lbs.) Height added to mast: 200 mm (7 ⁷/₈ in.)</p>
	<p>Lightning Event Counter (LEC IV)</p> <p>Purpose designed lightning event counter.</p> <p>I.P. Rating: IP67 Operating Temp. Range: 40°C to +50°C (-40°F to 122°F) Dimensions: 110 mm(h) x 80 mm(w) x 90 mm(d) 4 ¹¹/₃₂ (h) x 3 ⁵/₃₂ (w) x 2 ⁷/₈ (d) Weight: 0.4 kg</p>
	<p>Terminal Lug Coupling</p> <p>The terminal lug coupling allows for connection of a conventional downconductor such as 25 mm x 3 mm copper tape / bar to the ERITECH® DYNASPHERE. See <i>Upper Termination Instructions</i> for fixing of coupling to ERITECH DYNASPHERE.</p> <p>Material: Brass Alloy 384D Length: 68.75 mm (2 ¹¹/₁₆ in.) Weight: 181 grams (6.38 oz.) Diameter: 25.4 mm (1 in.)</p>
	<p>Guy Ring</p> <p>Purpose designed guy ring, providing 3 guy anchoring points from the neck of the ERITECH DYNASPHERE.</p> <p>Height: 105.25 mm (4 ²/₁₆ in.) Inside Diameter: 60 mm (2 ⁶/₁₆ in.) Outside Diameter: 91 mm (3 ¹/₂ in.) Material: Cast Aluminum Guy Hole Diameter: 10 mm (⁶/₁₆ in.)</p>



	<p>Guy Kit</p> <p>Purpose designed guying kits for anchoring from a guy ring or inline coupling. Each kit comes complete with six stainless steel thimbles, plus 18 guying grips per kit. Refer to pages 44 and 45 for more detail.</p> <table data-bbox="380 304 987 408"> <thead> <tr> <th></th> <th>4 m Guy Kit</th> <th>7 m Guy Kit</th> </tr> </thead> <tbody> <tr> <td>Guy Diameter:</td> <td>4 mm ($\frac{5}{32}$ in.)</td> <td>5 mm ($\frac{3}{16}$ in.)</td> </tr> <tr> <td>Actual Guy Length:</td> <td>6 m (20 $\frac{1}{2}$ ft.)</td> <td>10 m (34 ft.)</td> </tr> <tr> <td>Guy Tensile Strength:</td> <td>430 kg (946 lb.)</td> <td>560 kg (1232 lb.)</td> </tr> </tbody> </table>		4 m Guy Kit	7 m Guy Kit	Guy Diameter:	4 mm ($\frac{5}{32}$ in.)	5 mm ($\frac{3}{16}$ in.)	Actual Guy Length:	6 m (20 $\frac{1}{2}$ ft.)	10 m (34 ft.)	Guy Tensile Strength:	430 kg (946 lb.)	560 kg (1232 lb.)
	4 m Guy Kit	7 m Guy Kit											
Guy Diameter:	4 mm ($\frac{5}{32}$ in.)	5 mm ($\frac{3}{16}$ in.)											
Actual Guy Length:	6 m (20 $\frac{1}{2}$ ft.)	10 m (34 ft.)											
Guy Tensile Strength:	430 kg (946 lb.)	560 kg (1232 lb.)											
	<p>ERITECH® ERICORE Downconductor Saddles</p> <p>Purpose designed saddles for securing of downconductor to structure.</p> <table data-bbox="380 624 785 746"> <tbody> <tr> <td>Material:</td> <td>Stainless Steel 316</td> </tr> <tr> <td>Length:</td> <td>114.5 mm (4 $\frac{1}{2}$ in.)</td> </tr> <tr> <td>Thickness:</td> <td>1.2 mm ($\frac{1}{16}$ in.)</td> </tr> <tr> <td>Fixing Hole Diameter:</td> <td>6 mm ($\frac{4}{16}$ in.)</td> </tr> <tr> <td>Width:</td> <td>25.5 mm (1 in.)</td> </tr> </tbody> </table>	Material:	Stainless Steel 316	Length:	114.5 mm (4 $\frac{1}{2}$ in.)	Thickness:	1.2 mm ($\frac{1}{16}$ in.)	Fixing Hole Diameter:	6 mm ($\frac{4}{16}$ in.)	Width:	25.5 mm (1 in.)		
Material:	Stainless Steel 316												
Length:	114.5 mm (4 $\frac{1}{2}$ in.)												
Thickness:	1.2 mm ($\frac{1}{16}$ in.)												
Fixing Hole Diameter:	6 mm ($\frac{4}{16}$ in.)												
Width:	25.5 mm (1 in.)												
	<p>Stainless Steel Cable Tie</p> <p>Purpose designed cable ties for securing of ERITECH ERICORE downconductor to structures.</p> <table data-bbox="380 965 880 1093"> <tbody> <tr> <td>Length:</td> <td>521 mm (20 $\frac{1}{2}$ in.)</td> </tr> <tr> <td>Width:</td> <td>7.9 mm ($\frac{5}{16}$ in.)</td> </tr> <tr> <td>Material:</td> <td>Stainless Steel</td> </tr> <tr> <td>Maximum Bundle Diameter:</td> <td>152 mm (6 in.)</td> </tr> <tr> <td>Minimum Loop Tensile Strength:</td> <td>250 lbs.</td> </tr> </tbody> </table>	Length:	521 mm (20 $\frac{1}{2}$ in.)	Width:	7.9 mm ($\frac{5}{16}$ in.)	Material:	Stainless Steel	Maximum Bundle Diameter:	152 mm (6 in.)	Minimum Loop Tensile Strength:	250 lbs.		
Length:	521 mm (20 $\frac{1}{2}$ in.)												
Width:	7.9 mm ($\frac{5}{16}$ in.)												
Material:	Stainless Steel												
Maximum Bundle Diameter:	152 mm (6 in.)												
Minimum Loop Tensile Strength:	250 lbs.												

Glossary for terms used in this text

Securing

Saddles, cable hangers or clamps used to mechanically and electrostatically secure the downconductor to the structure.

Bond

Electrical connection between the outer semi-conductive sheath of the downconductor and other electrically conductive materials.

Clamp

Electrically conductive, mechanical anchoring of the downconductor to the structure.

Conductive Structural Point

Any point of the structure that is electrically conductive and is either connected to the structure earth or has a substantial metallic mass.

Fastenings

Bolts, screws, masonry anchors or other hardware used to secure anchors to the structure.

FRP

Fiberglass Reinforced Plastic. Insulated mast for mounting ERITECH® DYNASPHERE.

Metallic Mast Section

Any type of electrically conductive mast section, ie: aluminum masts, galvanized free standing mast, etc.

Structure Bonding Braid

Conductive lead at the base of the upper termination used to electrostatically bond the downconductors' outer sheath to a conductive structural point if the downconductor cannot be clamped to a conductive structural point within 5 m (17 ft.) of the upper termination.





CERTIFICATE OF COMPLIANCE & WARRANTY REGISTRATION

For warranty purposes, please ensure that you are registered for warranty service, by completing and mailing this card to ERICO®, preferably within seven (7) days of installation.

Number of Contract: _____ Date of Contract: _____ Project: _____

Date of Installation: _____ Date of Inspection: _____ Address: _____

Installation Contractor: _____

Address: _____

Installed by: _____ Type of Structure : _____

Terminal Type(s): _____

Serial Number(s): _____

Number of Terminals: _____

No., Length & Type of Downconductors: _____

Maximum Ground Resistance: _____

Description of Ground System: _____

IMPORTANT NOTICE:

This lightning protection system **MUST** be regularly maintained strictly to the instructions of the Manufacturer at least once a year.

Design File No.: _____

Statistical level of protection: _____ %

Distributor: _____

This certificate is to certify that the installation and equipment is in accordance with the requirements of ERICO

Tests witnessed by accredited representative of the owner

The accredited representative of ERICO

Signed: _____ Name: _____

Signed: _____ Name: _____

AFFIX
STAMP
HERE

The Customer Service Manager
ERICO
34600 Solon Road
Solon, OH 44139
USA



ERICO®
www.erico.com



10 YEAR LIMITED WARRANTY

This product has a limited warranty to be free from defects in materials and workmanship for a period of ten (10) years from the date of dispatch from the Manufacturer. The Purchaser acknowledges that lightning is a natural event with statistical variation in behavior and energy levels which may exceed product ratings, and 100% protection is not offered and cannot be provided for. Therefore the Manufacturer's liability is limited to the repair or replacement of the product (at the Manufacturer's sole option) which in its judgement has not been abused, misused, interfered with by any person not authorized by the Manufacturer, or exposed to energy or transient levels exceeding the Manufacturer's specifications for the product. The product must be installed and earthed (where applicable) in strict accordance with the Manufacturer's specifications and all relevant national Electricity and Safety Standards. The Manufacturer and the Purchaser mutually acknowledge that the product by its nature may be subject to degradation as a consequence of the number and severity of surges and transients that it experiences in normal use and this warranty excludes such gradual or sudden degradation. This warranty does not indemnify the Purchaser of the product for any consequential claim for damages or loss of operations or service or profits. Customers should contact their nearest ERICO agent to obtain a Product Repair Authorization Number prior to making any claim under this warranty. This is only a summary of the warranty given by the Manufacturer. The full text of the warranty is set out in the Manufacturer's Conditions of Quotation and Sale.

ERICO®



www.erico.com



AUSTRALIA
Phone 1800-263-508
Fax 1800-423-091



CHINA
Phone +86-21-3430-4878
Fax +86-21-5831-8177



HUNGARY
Phone 06-800-16538
Fax +31-13-583-5406



NORWAY
Phone 800-100-73
Fax 800-100-66



SWITZERLAND
Phone 0800-55-86-97
Fax 0800-55-96-15



BELGIUM
Phone 0800-757-48
Fax 0800-757-60



DENMARK
Phone 808-89-373
Fax 808-89-372



INDONESIA
Phone +62-21-575-0941
Fax +62-21-575-0942



POLAND
Phone +66-2-267-5776
Fax +48-71-349-04-61



THAILAND
Phone +66-2-267-5776
Fax +66-2-636-6988



BRAZIL
Phone +55-11-3623-4333
Fax +55-11-3621-4066



FRANCE
Phone 0800-901-793
Fax 0800-902-024



ITALY
Phone 800-870-938
Fax 800-873-935



SINGAPORE
Phone +65-6-268-3433
Fax +65-6-268-1389



UNITED ARAB EMIRATES
Phone +971-4-881-7250
Fax +971-4-881-7270



CANADA
Phone +1-800-677-9089
Fax +1-800-677-8131

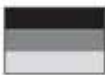

GERMANY
Phone 0 800-189-0272
Fax 0 800-189-0274



MEXICO
Phone +52-55-5260-5991
Fax +52-55-5260-3310



SPAIN
Phone 900-993-154
Fax 900-993-106



UNITED KINGDOM
Phone +0808-2344-670
Fax +0808-2344-676



CHILE
Phone +56-2-370-2908
Fax +56-2-369-5657



HONG KONG
Phone +852-2764-8808
Fax +852-2764-4486



NETHERLANDS
Phone +31-13-583-5400
Fax +31-13-583-5499



SWEDEN
Phone 020-790-908
Fax 020-798-964



UNITED STATES
Phone +1-440-248-0100
Fax +1-440-248-0723

WARNING

ERICO products shall be installed and used only as indicated in ERICO's product instruction sheets and training materials. Instruction sheets are available at www.erico.com and from your ERICO customer service representative. Improper installation, misuse, misapplication or other failure to completely follow ERICO's instructions and warnings may cause product malfunction, property damage, serious bodily injury and death.

Copyright ©2009, 2012 ERICO International Corporation. All rights reserved.

CADDY, CADWELD, CRITEC, ERICO, ERIFLEX, ERITECH, and LENTON are registered trademarks of ERICO International Corporation.